

Split Type Filling System



Features

- | Split design, adding or deleting filling units freely.
- | One controller can control 1-16 filling units.
- | Each filling unit can receive stop filling signal when bottle absent.
- | You can check the working status of the filling units from controller.

Model Number

- | CF600, CF600 Plus, CF600II, CF600II Plus

Typical Application

- | Laboratory dispensing
- | Industry filling

External Control Schematic Diagram

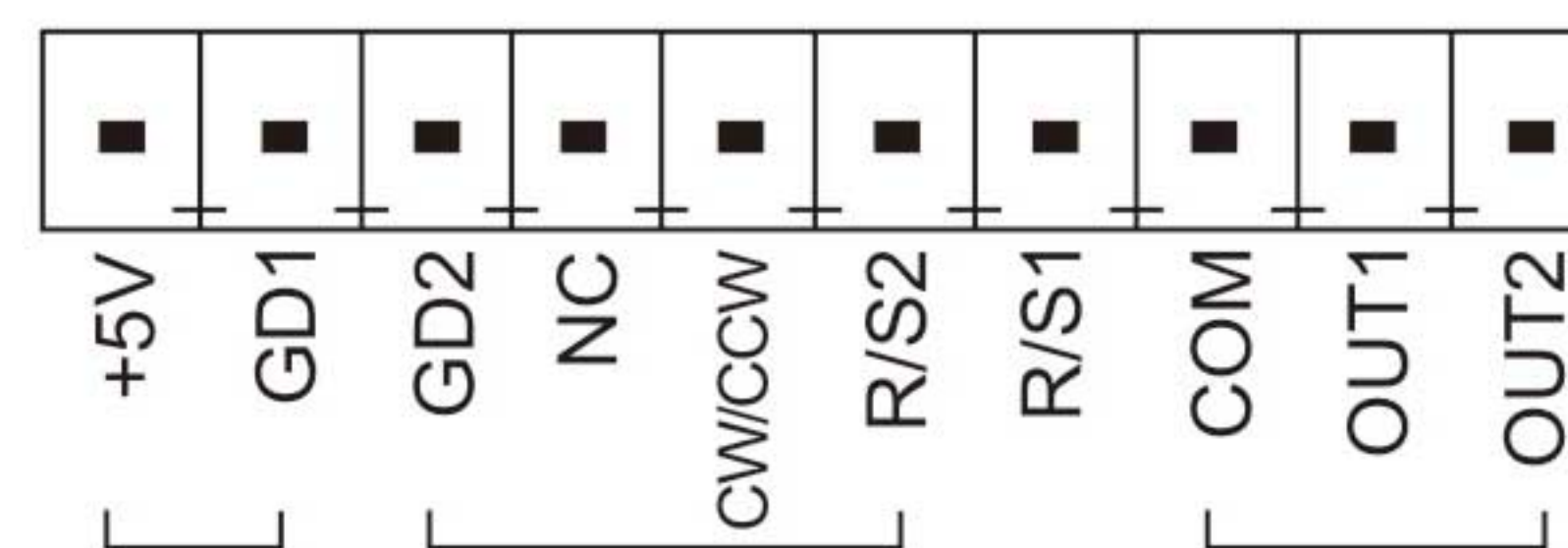

Dimension Drawing(Unit: mm)

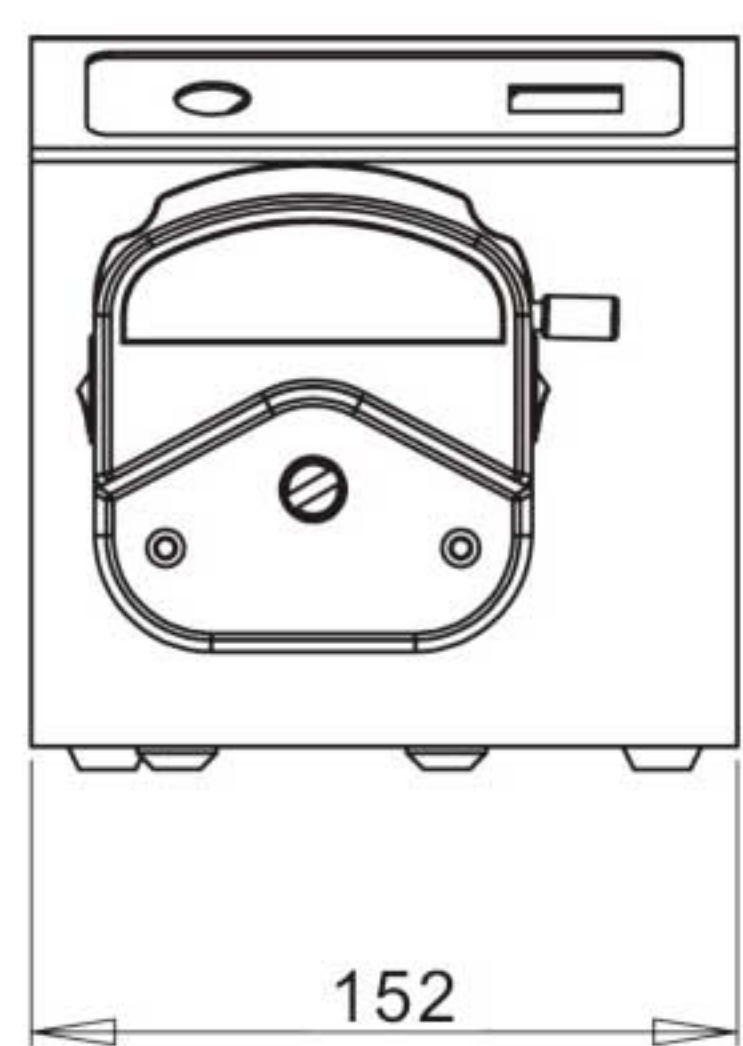

Drive Dimension Drawing

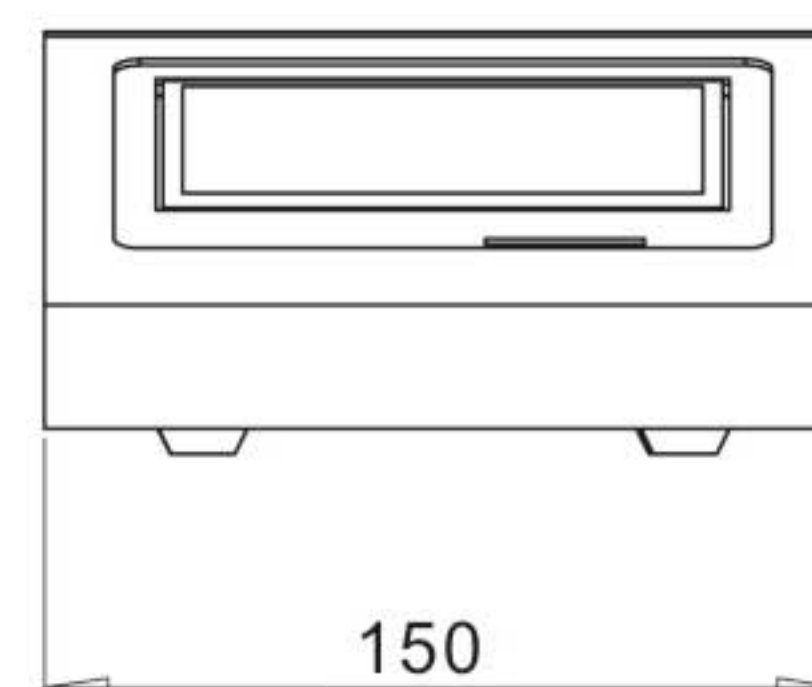
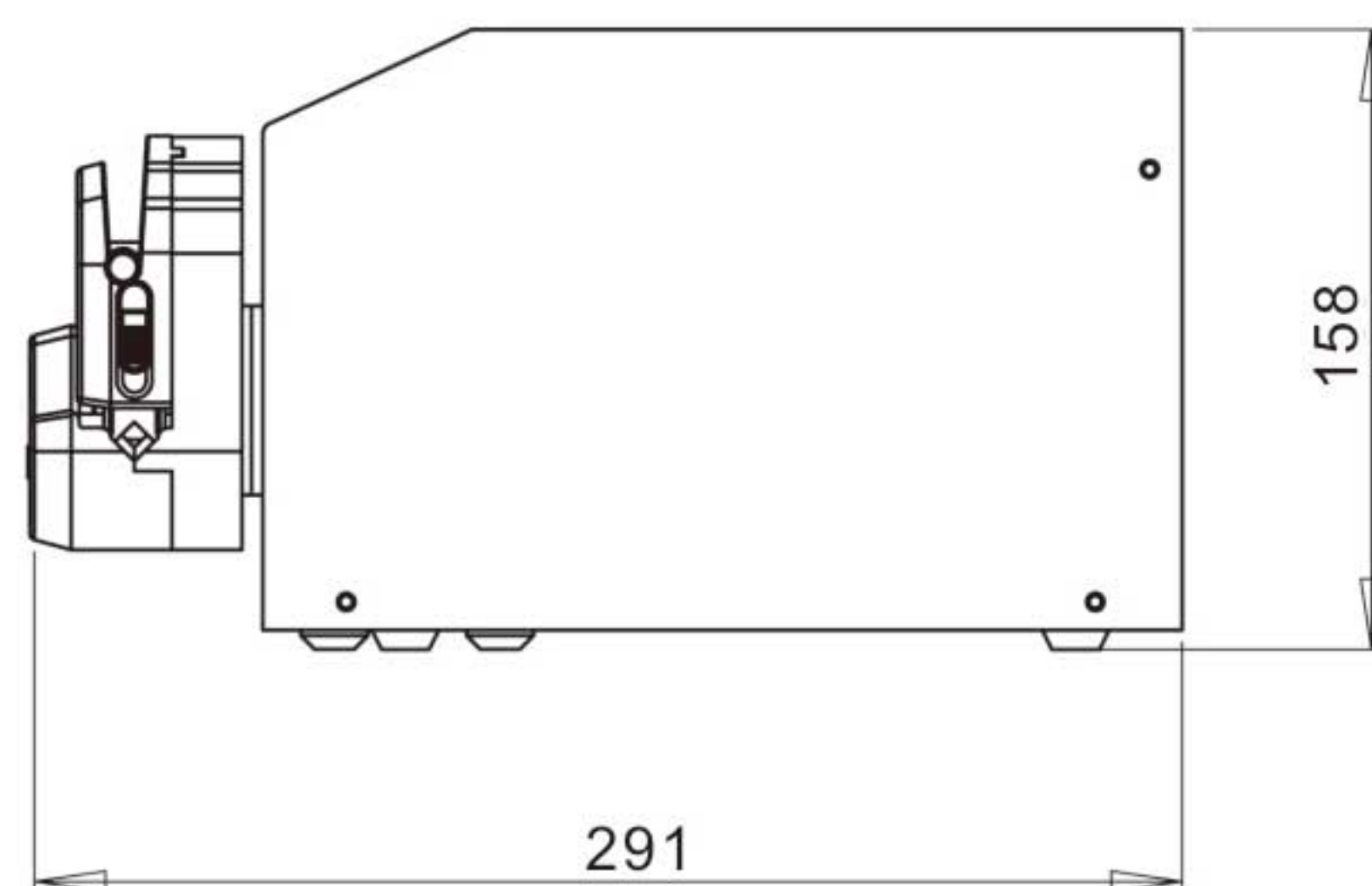

Controller Dimension Drawing

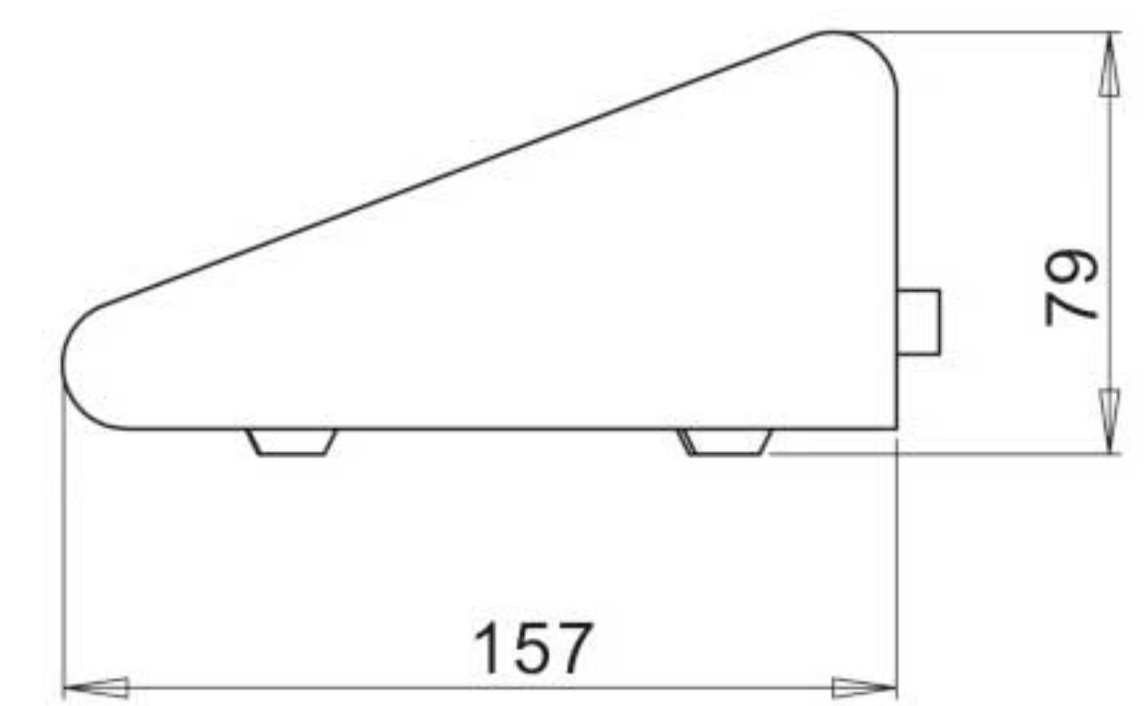

Technical Specifications				
Speed range	CF350/DF350	1-350 rpm	Display	4.3" industrial grade true color LCD screen
	CF350 Plus/DF350 Plus	1-350 rpm	Control method	Touch screen and mechanical keypad
	CF600 Series	1-600 rpm	Keypad lifetime	300,000 times
	DF600 Series	1-600 rpm	Start/stop, direction signal	Passive switch signal, such as foot pedal switch Active switch signal: 5V, 12V, 24V for option
Filling volume range	0.1-9999.99 mL		Output interface	Output motor working status (Open-Collector output)
Filling time range	0.5-9999.99 s/ DF600 Plus 0.1-9999.99 s			
Pause time range	0.5-9999.99 s/ DF600 Plus 0.1-9999.99 s		Power supply	AC 220V±10% 50Hz/60Hz (standard) AC 110V±10% 50Hz/60Hz (optional)
Filling volume resolution	0.01 mL			
Time resolution	0.01 s		Condition temperature	0-40°C
Copy numbers	1-9999,'0' means unlimited		Relative humidity	< 80%
Back suction angle	0-360°		IP rate	IP31
Filling accuracy	<±0.5%			

Product Composition and Flow Rate Range						
Drive	Pump Head	Pump Head Material	Tube Clamp Material	Tubing		(Motor Speed 1~600rpm) Flow Rate mL/min
				Tubing Size	ID×Wall Thickness	
DF600 CF600 DF600 Plus CF600 Plus	YZ1515x	PSF PPS	————	13 [#]	0.8×1.6 (mm)	0.07~42
				14 [#]	1.6×1.6 (mm)	0.27~162
				19 [#]	2.4×1.6 (mm)	0.55~330
				16 [#]	3.1×1.6 (mm)	0.82~492
	YZ2515x	PSF PPS	————	25 [#]	4.8×1.6 (mm)	1.7~1020
				17 [#]	6.4×1.6 (mm)	2.9~1740
				18 [#]	7.9×1.6 (mm)	3.8~2280
				15 [#]	4.8×2.4 (mm)	1.7~1020
DF600II CF600II DF600 PlusII CF600PlusII	DZ25-3L	Aluminum alloy/PPS	PP	24 [#]	6.4×2.4 (mm)	3.85~2310
				35 [#]	7.9×2.4 (mm)	5.08~3050
				36 [#]	9.6×2.4 (mm)	6~3600
				15 [#]	4.8×2.4 (mm)	2.11~1264
DF600III CF600III DF600 PlusIII CF600 PlusIII	DZ25-6L	Aluminum alloy/PPS	PP	24 [#]	6.4×2.4 (mm)	5.5~3300
				35 [#]	7.9×2.4 (mm)	8~4800
				36 [#]	9.6×2.4 (mm)	10~6000
				15 [#]	4.8×2.4 (mm)	3~1800
DF600IV CF600IV DF600 PlusIV CF600 PlusIV	YZ35-PPS	PPS	PP	26 [#]	6.4×3.3 (mm)	6.9~4200
				73 [#]	9.6×3.3 (mm)	12.3~7400
				82 [#]	12.7×3.3 (mm)	20~12000
Drive	Pump Head	Pump Head Material	Tube Clamp Material	Tubing		(Motor Speed 1~350rpm) Flow Rate mL/min
				Tubing Size	ID×Wall Thickness	
DF350 CF350 DF350 Plus CF350 Plus	DY15	Aluminum alloy	PP	13 [#]	0.8×1.6 (mm)	0.1~48
				14 [#]	1.6×1.6 (mm)	0.6~223
				19 [#]	2.4×1.6 (mm)	1.3~448
				16 [#]	3.1×1.6 (mm)	2~723
				25 [#]	4.8×1.6 (mm)	4.7~1626
				17 [#]	6.4×1.6 (mm)	6.4~2230
	DY25	Aluminum alloy	PP	18 [#]	7.9×1.6 (mm)	9.5~3337
				15 [#]	4.8×2.4 (mm)	4.2~1480
				24 [#]	6.4×2.4 (mm)	7.6~2670
				35 [#]	7.9×2.4 (mm)	10~3600
				36 [#]	9.6×2.4 (mm)	12.4~4340



Filling Volume Reference (Media is water)							
Drive	Pump Head	Tubing	Filling Volume (mL)	Filling Time (s)	Accuracy (±%)	Output (pcs/min)	Motor Speed (rpm)
DF600 CF600 DF600 Plus CF600 Plus	YZ1515x YZ2515x	13 [#]	0.1	0.5	±5ul	40	204.083
		13 [#]	0.3	0.7	1.5	35	426.251
		13 [#]	0.5	1	0.8	30	516.081
		13 [#]	1	2	0.5	20	517.152
		14 [#]	2	1	1	30	446.724
		14 [#]	3	1.5	0.8	24	446.479
		19 [#]	5	1.2	1	27	454.919
		16 [#]	7	1	0.5	30	457.705
		25 [#] /15 [#]	10	1	1	30	303.426
		25 [#] /15 [#]	15	1	0.8	30	461.273
		25 [#] /15 [#]	20	1.2	0.5	27	518.945
		17 [#] /24 [#]	30	1.2	0.8	27	462.725
		17 [#] /24 [#]	50	2	0.5	20	461.595
		18 [#]	80	2.5	0.5	17	427.274
		18 [#]	100	3	0.5	15	446.583
DF600II CF600II DF600 PlusII CF600PlusII	DZ25-3L	15 [#]	16	1	0.5	30	454.976
		24 [#]	30	1.2	0.5	27	389.610
		35 [#]	150	4	0.5	12	442.913
		36 [#]	200	4	0.5	12	500.000
DF350 CF350 DF350 Plus CF350 Plus	DY15	14 [#]	0.5	0.5	0.3	60	94.1915
		14 [#]	1	1	0.4	30	94.1915
		14 [#]	2	1	0.6	30	188.383
		19 [#]	3	1	0.3	30	140.625
		16 [#]	5	1	0.5	30	145.278
		25 [#]	10	1	0.3	30	129.143
		25 [#]	15	1	0.4	30	193.715
		17 [#]	30	1	0.4	30	282.530
	DY25	18 [#]	100	2.5	0.3	17	251.730
		15 [#]	10	1	0.3	30	141.911
		24 [#]	30	1	0.5	30	235.972
		35 [#]	70	1.2	0.4	27	340.466
		36 [#]	100	2	0.2	20	241.935
		15 [#]	80	4	0.4	12	400.000
DF600III CF600III DF600 PlusIII CF600 PlusIII	DZ25-6L	24 [#]	150	4	0.4	12	409.090
		35 [#]	200	3.2	0.5	14	468.750
		36 [#]	300	3.5	0.5	13	514.285
		26 [#]	150	3	0.5	15	428.570
DF600IV CF600IV DF600 PlusIV CF600 PlusIV	YZ35-PPS	73 [#]	300	3	0.5	15	486.499
		82 [#]	500	3	0.5	15	500.000

