

# OEM Product

## Standard Pump Head Series

### OEM-B130/SN Series

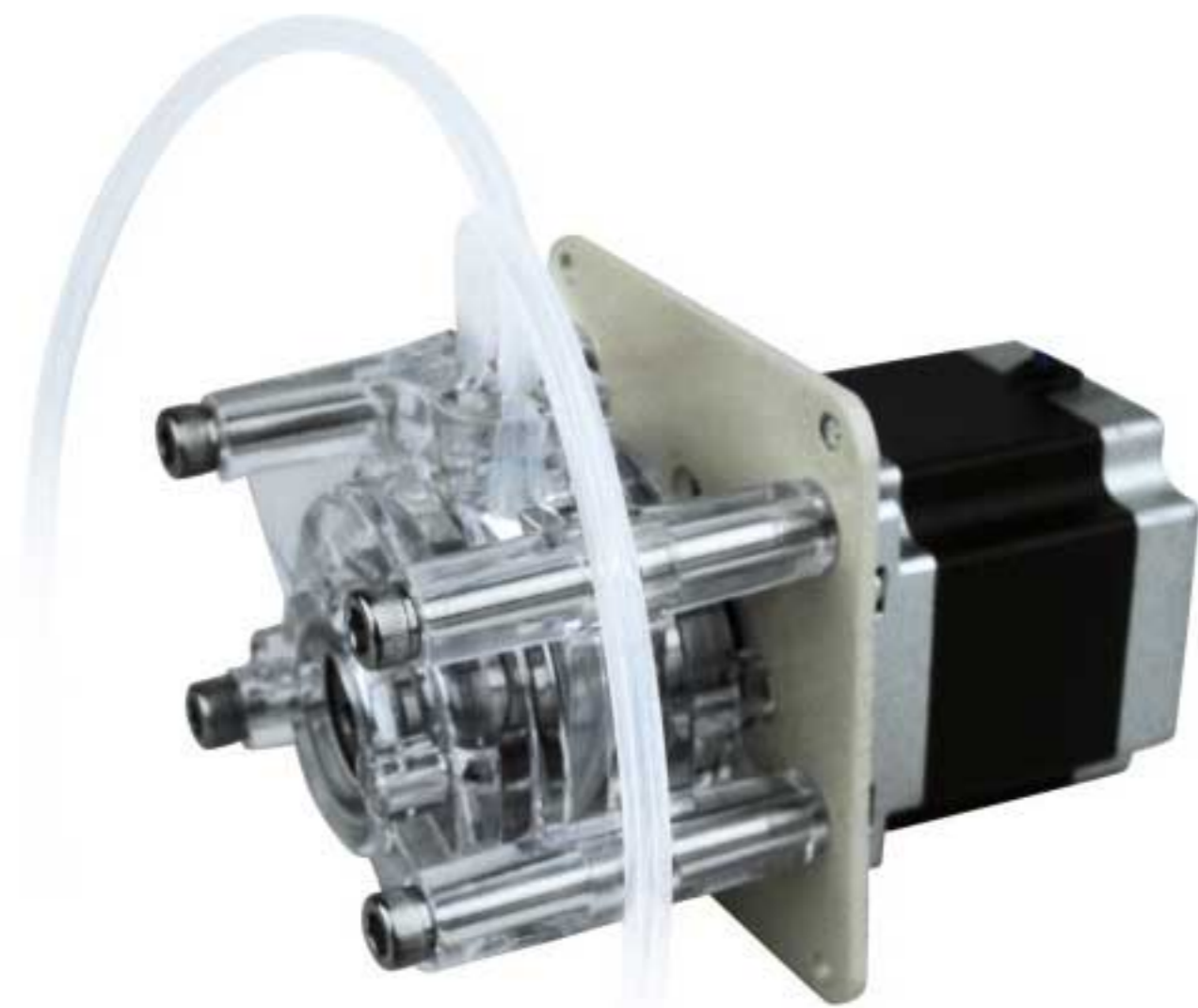

Dimension Drawing(Unit: mm)

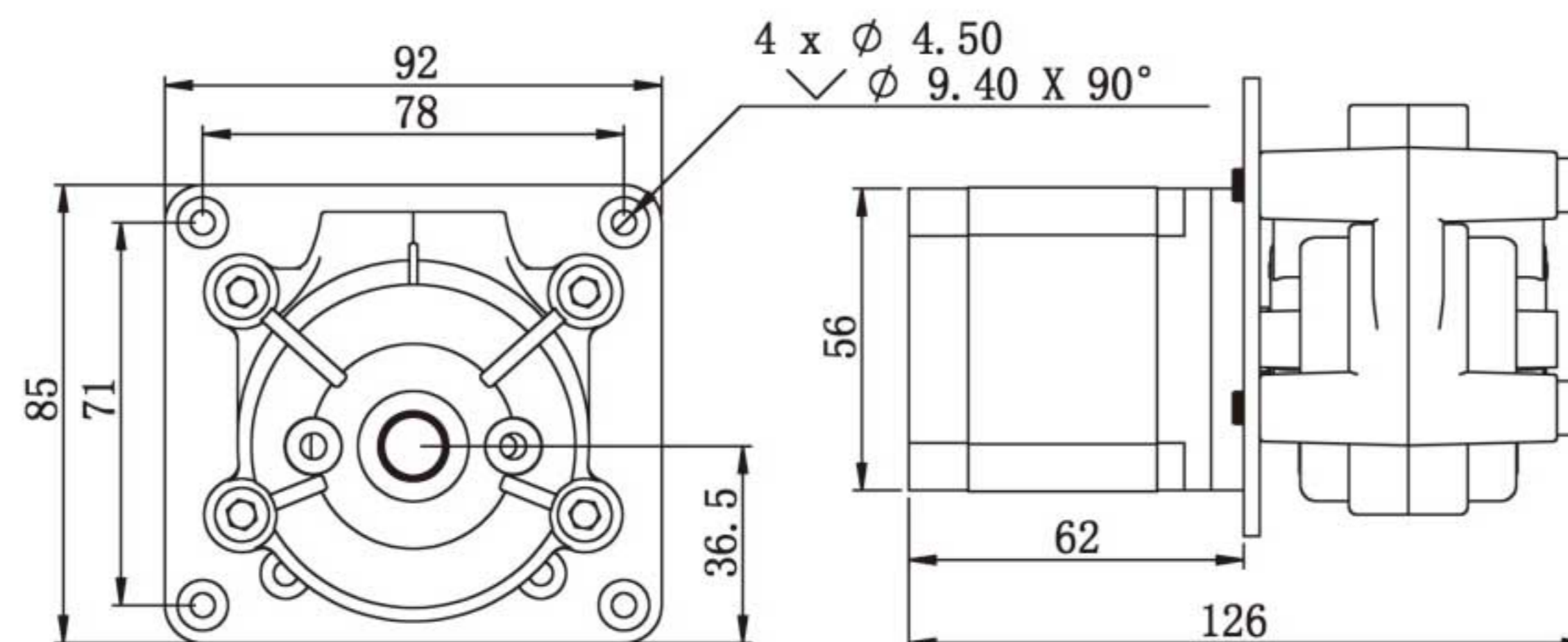

Model No.	OEM-B130
Speed range	0.1-350 rpm
Flow rate range	0.024-875mL/min
Motor type	57 stepper motor
Motor phase number	2
Motor step angle	1.8°
Motor phase voltage	3.3V
Motor phase current	3.0A
Working environment	0-40°C, 80%RH

### OEM-B19/SN Series



Dimension Drawing(Unit: mm)

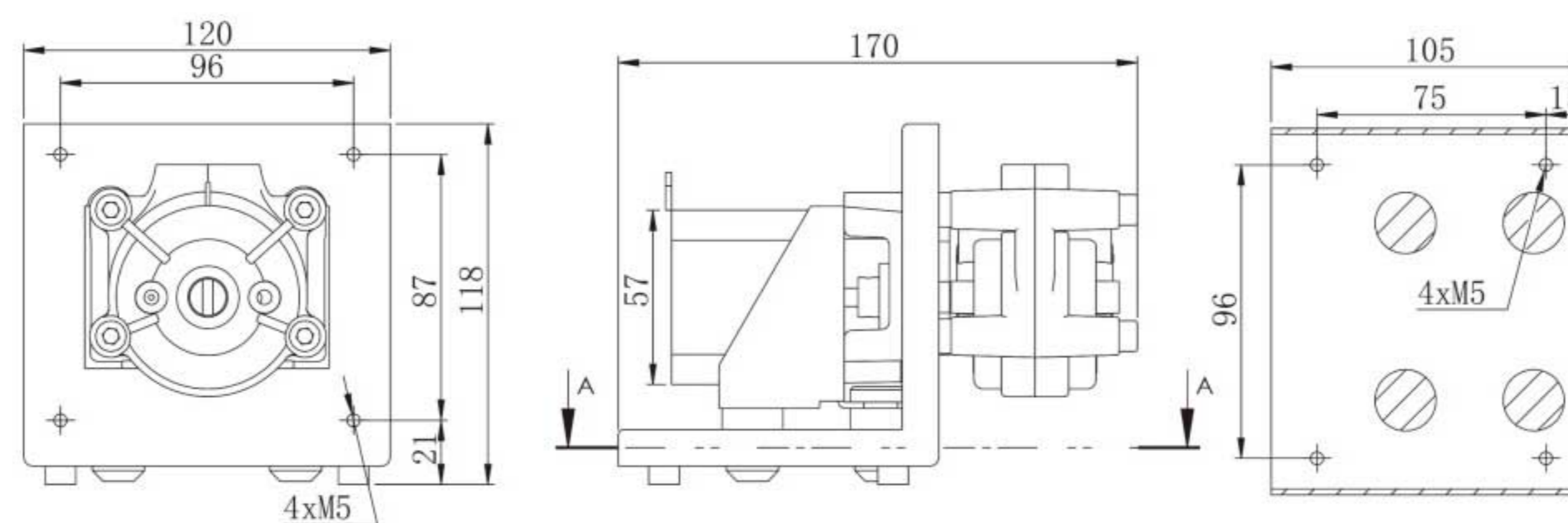

Model No.	OEM-B19
Speed range	0.1-350 rpm
Flow rate range	0.024-875mL/min
Motor type	57 stepper motor
Motor phase number	2
Motor step angle	1.8°
Motor phase voltage	3.3V
Motor phase current	3.0A
Working environment	0-40°C, 80%RH

### OEM-B11/SN Series



Dimension Drawing(Unit: mm)

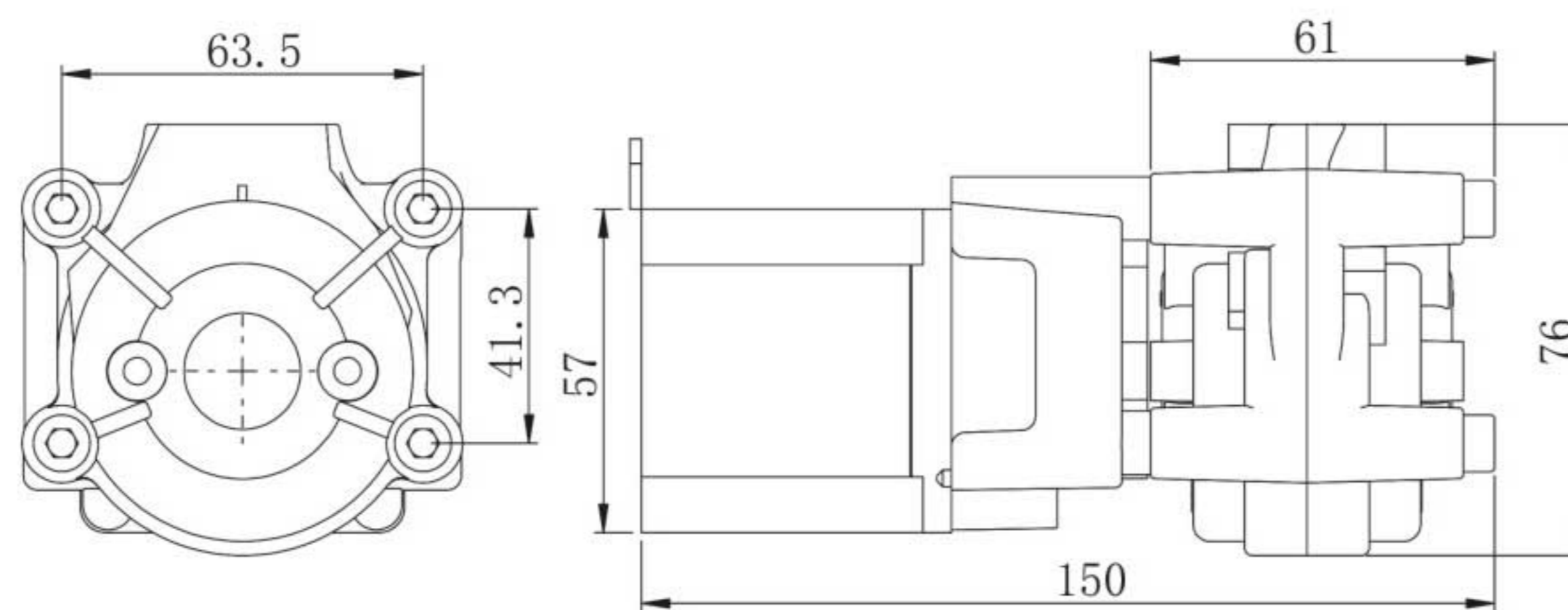

Model No.	OEM-B11
Speed range	0.1-350 rpm
Flow rate range	0.024-875mL/min
Motor type	57 stepper motor
Motor phase number	2
Motor step angle	1.8°
Motor phase voltage	3.3V
Motor phase current	3.0A
Working environment	0-40°C, 80%RH

### OEM-Z109 ( DC motor ) /SN Series

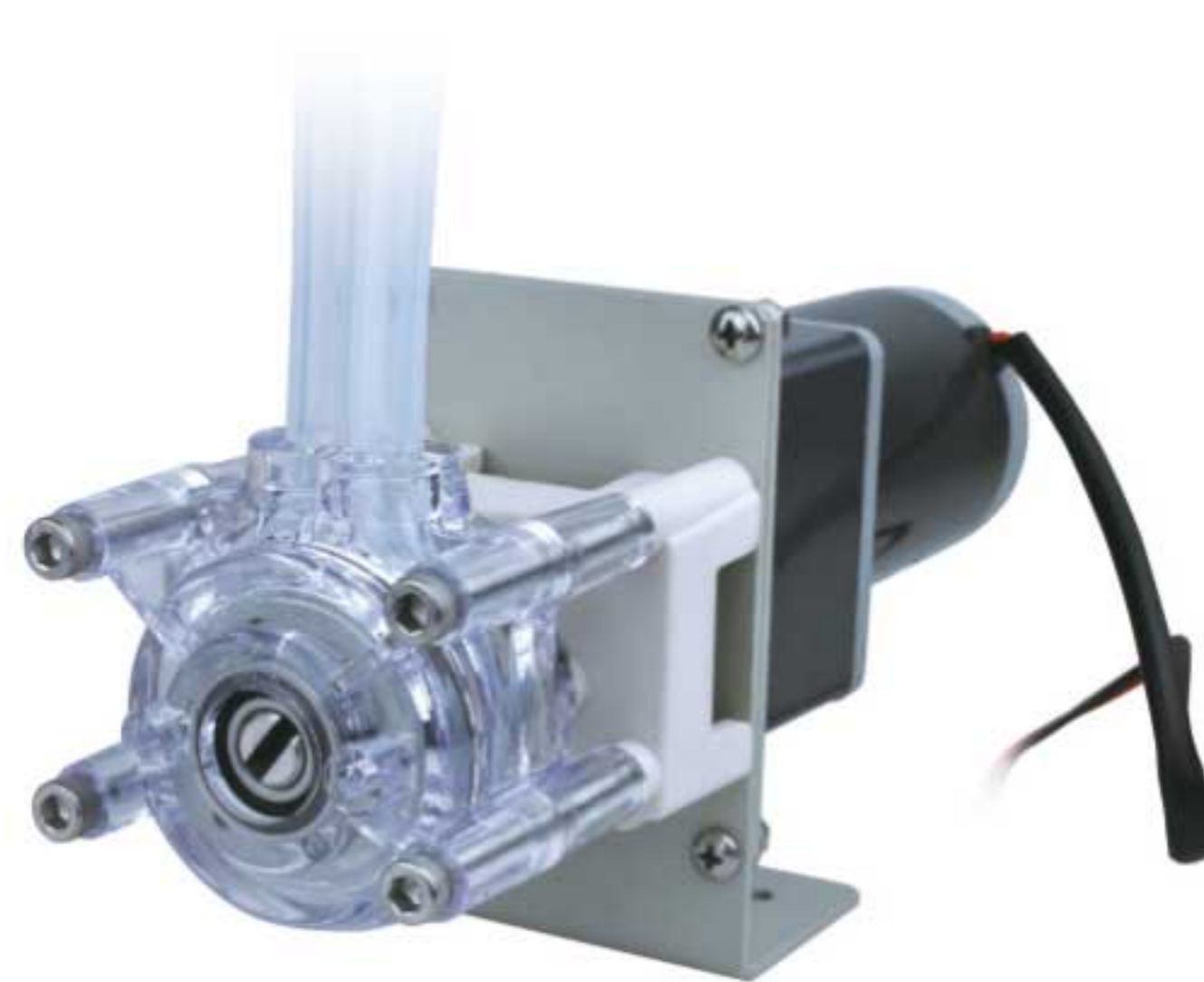

Dimension Drawing(Unit: mm)

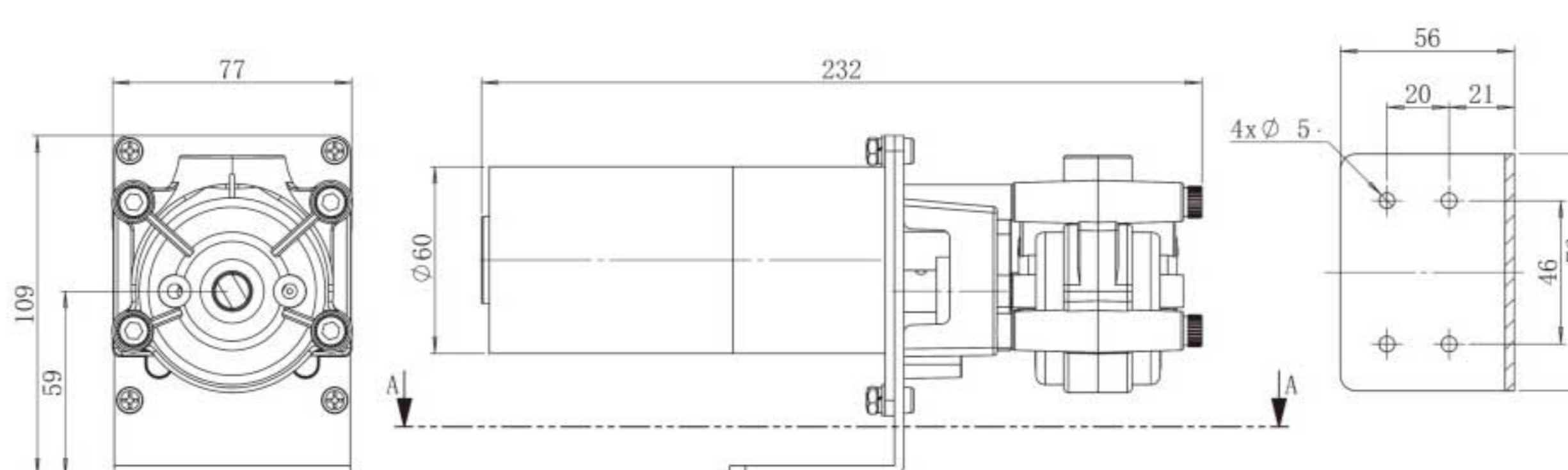

Model No.	OEM-Z109
Mix.flow rate	1500mL/min
Motor type	DC geared motor
Voltage	DC12V/2A
Power	15W
Speed	600rpm
Speed error	≤ ±10%
Working environment	0-40°C, 80%RH

### OEM-JT03 ( AC motor ) /SN Series



Dimension Drawing(Unit: mm)

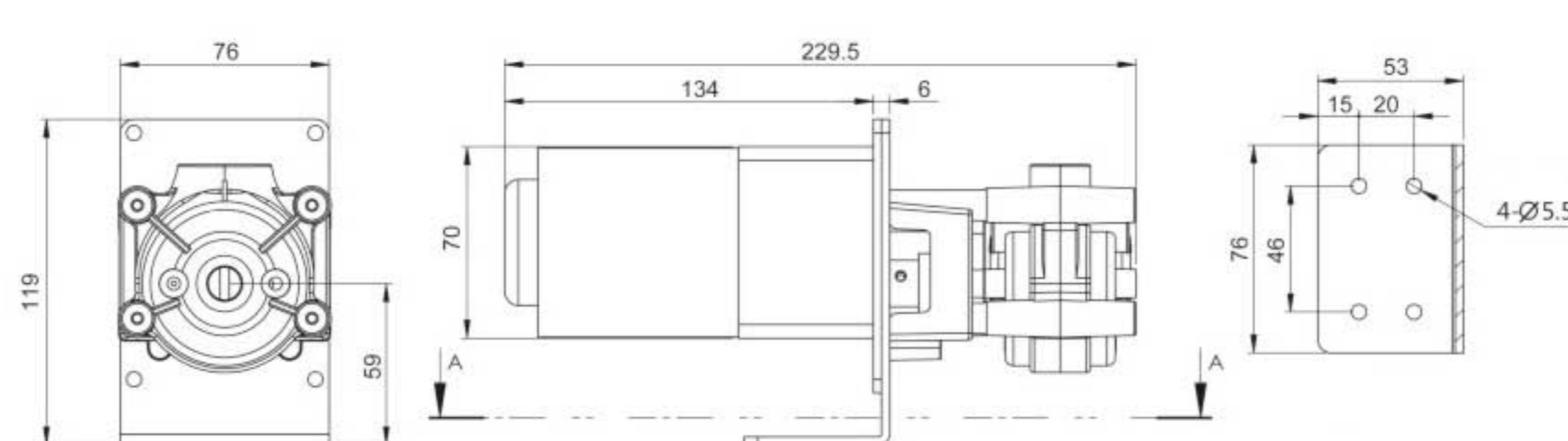

Model No.	OEM-JT03
Flow rate	7.2-750mL/min
Motor type	AC speed motor
Voltage	AC220V(standard) DC110V(optional)
Power	15W
Speed	600rpm
Speed error	≤ ±10%
Working environment	0-40°C, 80%RH

