



Made in Germany

Lab Equipment Line

Safety System for HPLC

Safety Cap | Safety Waste Cap | Safety Funnel



EXTRACTION SYSTEMS



WASTE SYSTEMS



SAFETY FUNNELS



OVER 600 PRODUCTS OF OUR OWN DEVELOPMENT



We bring you safety and comfort.

„Work in the laboratory requires a high level of concentration and is often subject to high performance pressure. Therefore it is important for colleagues to work with the best possible devices and resources.“

„THE MOST ESSENTIAL VALUE IS THE HEALTH OF HUMANS IN THE LABORATORY AND MAINTAINING HEALTH IS A SIGNIFICANT PART OF OUR STRATEGY AND WORK.“

Perfect materials and simple, but absolutely safe, handling are the preconditions for safety. This is what products from S.C.A.T. provide with a guarantee you can count on. All S.C.A.T. products are developed in close collaboration with major German chemical and pharmaceutical firms. Here, chemists, engineers and technicians have deliberated, developed and manufactured for colleagues. Our company was founded to implement maximum safety standards and to guarantee them over the long term. S.C.A.T. Europe stands for Safety-Center-Analyses-Technology. We follow this idea with pleasure and success. Of course we would be happy to serve you and your colleagues as customers.



Yours sincerely
S.C.A.T. Europe GmbH

A handwritten signature in blue ink, appearing to read 'J. Rittgasser', written in a cursive style.

Johann Rittgasser
Owner and president

Safety Solutions - Made in Germany.

„The team from S.C.A.T. Europe listens, learns and develops series products based on individual solutions to problems – products that make laboratories all over the world safer and more efficient“.

From our base at Mörfelden in Germany, we at S.C.A.T. Europe make laboratories all over the world safer and more efficient. S.C.A.T. Europe's safety solutions are about much more than just

Let us tell you about our favourite example of an enquiry sent to us and our outstanding solution, which has since become an established global safety standard:



S.C.A.T. Europe GmbH - headquarters in Mörfelden

Development, engineering, sales and logistics - all under one roof.

delivering on a promise. Our entire company philosophy is based on finding solutions to your problems.

Stronger together!

Many of our products are originally conceived as solutions to the individual problems that you ask us to help with. Most of the standard products in this catalogue started out life in this way, and were then developed into series products. In the future, too, we'll continue to seek out the solutions to your specific laboratory, process and production issues – wherever you require assistance in ensuring the safe handling of liquid chemicals.

Our customer's HPLC system, which would easily have cost up to six figures to buy, was drawing solvents from open or improperly sealed storage bottles. As a result, air, dust and dirt particles could be drawn into capillaries that were not properly fastened into position, and subsequently make their way into the highly sensitive analysis devices. Capillaries were getting tangled during use and replacement of the storage bottles. Highly volatile substances were being lost as vapour, mixing ratios were affected and incorrect analysis results were proving time-consuming and expensive to correct. To top it off, laboratory staff were permanently exposed to health risks caused by solvent vapours escaping into the ambient air!

Suppliers of the equipment leave it up to the user to obtain the bottles which the system needs to operate. The equipment is supplied with seals for GL 45 threaded bottles, which have openings or holes for capillaries with an external diameter of

Development, engineering, production, logistics. From special products to series lines. All under one roof!

3.2 mm. Suppliers rarely or never consider the safe disposal of used eluents.

Our solution is used in laboratories across the world to ensure that hazardous liquids can be handled efficiently and safely: S.C.A.T. SafetyCaps guarantee the safe extraction of solvents from storage containers, while SafetyWasteCaps ensure that solvents can be collected safely and that waste containers are ventilated effectively.

S.C.A.T. SafetyCaps – for the extraction of solvents. Made from pure PTFE and other high-quality plastics, SafetyCaps create a gas-tight seal on storage containers. Capillaries are fixed securely into place with fittings, while the rotatable core of the SafetyCap makes it easy to replace or change the storage container. The integrated air valve acts both as a valve and a filter.

This brilliantly simple – and simply brilliant – solution is completely unique in the global laboratory equipment market!

S.C.A.T. SafetyWasteCaps – for the disposal of waste liquids. This solution is made from high-quality materials and is resistant to organic solvents,

acids and lyes. Capillaries and tubes are securely connected to the SafetyWasteCap using fittings and tube fittings. Waste liquids are safely directed into the containers. Exhaust filters with a multi-component granulate remove all solvent vapours from the expelled air, ensuring that your working area is kept safe and clean.

With over twenty years of experience, we make laboratories a safer place to be. For the day-to-day handling of hazardous liquids, we supply safety funnels to enable you to dispose of large and small quantities of waste liquid. We offer models with automatic closure mechanisms or shut-off valves integrated into the SafetyWasteCaps.

Our collection containers too are available in a wide range of sizes, types and materials, including electrically conductive PE-HD. From space-saving models to large waste canisters for higher volumes, with UN approval for the transport of hazardous goods on roads and industrial premises – we can offer the perfect solution for any application.



Engineering and development. Our team develops solutions for the individual challenges that our customers face.



The creation of individual solutions, development, engineering and production all go hand-in-hand – under one roof.



High-quality materials, devices and precision manufacture. The S.C.A.T. Europe quality promise.

S.C.A.T. Europe

Info graphic & facts

78 %



Global trust

80 % of HPLC users in Europe place their trust in us as a market leader and developer of S.C.A.T. SafetyCaps. In more than 150 countries (of 192 worldwide, equivalent to 78%), our products are contributing to increased safety in laboratories and production.

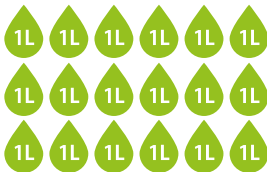

Air valves

A S.C.A.T. Europe air valve will prevent the evaporation of up to 750 ml of solvent over its service life of six months. In an HPLC system with four storage bottles, that adds up to a volume of three litres every six months. In a laboratory with six HPLC systems, the air valves prevent the evaporation of around 18 litres of liquid in a six-month period.

18 L

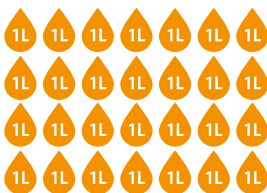

Exhaust filters

A S.C.A.T. Europe SafetyWasteCap with an exhaust filter fitted to a 10-litre waste canister will, compared to an open canister in an enclosed space, prevent the wastage of around 28 litres of solvent, which can be redirected back into the disposal cycle.

28 L



More than 600 products developed in-house. Made in Germany - ready to dispatch!

All of our products are compatible with our SafetyWasteCaps and the rest of the S.C.A.T. Europe System.

The fill level control system that we've already mentioned is another key component of our portfolio. This solution is included as part of our SafetyWasteCaps with integrated fill level control. SafetyWasteCaps with electronic fill level control or disc sensors on the exterior walls of containers can be connected to our electronic signal boxes.

S.C.A.T. Europe disposal units can be earthed. Our electrically conductive PE-HD products offer the best protection against fire in the laboratory if you are working with ignitable or flammable liquids.

Electrostatic risks in your laboratory?

S.C.A.T. Europe is the market leader in solutions for reducing the risk of fire in laboratories.

Turn to page XVIII of this catalogue to read a specialist article on this topic.

Our large range of accessories and consumables, including air valves and exhaust filters, thread adapters, earthing equipment and much more, guarantees continuous and long-lasting protection and makes it simple and safe to retrofit safety solutions to existing systems in your laboratory.

With S.C.A.T. Europe, you can ensure equipment is safe right from the start! S.C.A.T. Europe's safety solutions can also be integrated directly into your laboratory installations. In 2015, we created the SymLine® – Chemical Waste Systems product line from our „Laboratory installation“ product range. Early on in the planning of new laboratories, leading laboratory fitters incorporate SymLine® into their designs. The modular and flexible system is easy to integrate into existing laboratory installations too.

As you can see, you'd have a hard job to miss us in the laboratory equipment market. Our distinctive „Professor“ greets customers at trade fairs all over the world, at our own stands or those of our distributor partners. Looking for a distributor near you? Visit www.scatt-europe.com and „Find a distributor“. We'll then contact you with more information.

We hope you enjoy this catalogue.

- Your team at S.C.A.T. Europe -



More than 600 products developed in-house – Made in Germany – Ready to pack and dispatch to you.



S.C.A.T. is known as the „good brand“. Rather than GHS hazard symbols, we supply safety products with a GH smile ;-).



You can't miss us. Our „Professor“ greets customers at trade fairs across the world.

Safety Solutions Contents

EXTRACTION SYSTEMS - SafetyCaps



WASTE SYSTEMS - SafetyWasteCaps



SAFETY FUNNELS



LEVEL CONTROL

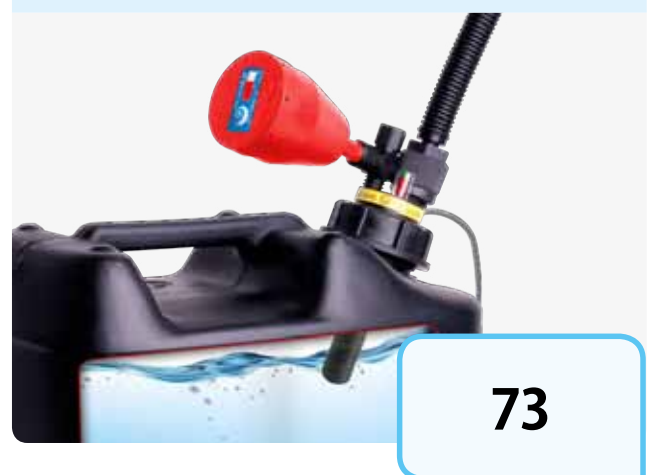

CONTAINERS

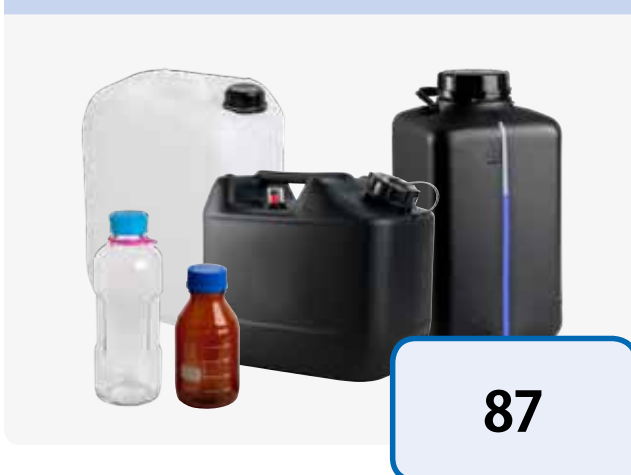

ACCESSORIES



Pages

Everything revolves around safety.

VIII-IX

Herbert Heidfeldt

Consultant for Environment, Health & Safety, Darmstadt, Germany

Safe handling of solvents in the laboratory.

X-XI

Michael Baldus

Product manager, NOVIA Chromatographie- und Messverfahren GmbH

Safety every day in the laboratory.

XII-XV

Test report

SGS Institut Fresenius was commissioned to investigate reduction of emissions achieved by use of S.C.A.T. SafetyCaps.

Electrostatic risks of ignition in your laboratory?

XVI-XXI

Kurt Moritz

is the specialist in charge of electrostatics and mechanical explosion protection for the technical plant safety of Merck KGaA, Darmstadt.

Protect your health.

XXII-XXIII

Key regulations & laws

S.C.A.T. Europe supports enterprises with consultation and can offer standard as well as customized solutions for all areas.

S.C.A.T. Europe Icons

XXIV-XXV

Icons

We have developed these icons to make it even easier for you to navigate through this catalog. This way, you can quickly and easily compare products and their features.

Everything revolves around safety.



„In the chemical laboratory, safety isn't self-evident. S.C.A.T. Europe helps its customers to achieve and maintain a very high degree of safety.“



Herbert Heidfeldt

Consultant for Environment, Health & Safety, Darmstadt, Germany

Herbert Heidfeldt began his career over 40 years ago in Research & Development at Merck KGaA. Since 2006, he has worked as a certified auditor, trainer and consultant for Corporate Environment, Health & Safety.

Working in the laboratory means managing complex tasks routinely and reliably. Therefore, this work demands placing a great deal of confidence in the facilities and in their own competence. More and more, supervisors and employees of chemical laboratories have to struggle with the growing occupational safety and legal requirements.

Along with the abundance of requirements, the need for professional help in order to provide competent and practical solutions for the user is also increasing.

Even as early as planning a laboratory, future risks can be reduced to a minimum by, for example, properly collecting hazardous materials that must be properly disposed of after use. Here, planners, managers and employees often focus on known safety facilities such as emergency exits and routes, signage, emergency showers and eye washes and fire fighting. However, these are only to emergency facilities designed to limit damage.

What about preventing these same emergencies from happening in the first place? The entire process chain of using chemicals is replete with dangers, especially their disposal.

Do you know how to handle all your materials properly and safely? Have you planned and tested emergency measures? Do employees receive regular training instruction? Is each next job (or the next upcoming experiment) thoroughly discussed and approved? Have you thought of everything? Or have you just been lucky so far?

Only one thing is certain: safety has many faces.

Especially in our workplaces in chemical laboratories, many sensible solutions help us handle materials properly. Information about chemicals can be found on labels, MSDSs or databases like the GESTIS database. So that practical implementation also goes smoothly, qualified equipment and tools are indispensable in today's workplace, especially when using hazardous substan-

„Working safely and efficiently in the laboratory is a constantly growing challenge.“



ces such as flammable solvents - reliably grounded work equipment is an absolute must. Here, you can't rely on your proverbial guardian angel. Work safety is always a system of interlocking work regulations and facilities. A grounded hopper also includes the right label, the right storage space for materials and the employee's dissipative safety shoes.

But the most dangerous hazards are invisible. An explosive atmosphere, for example, isn't recognizable at first glance. That's understandable, because humans just don't have innate senses to detect many situations. A suitable seal, a hose connection or the right packaging material help minimize these dangers.

Working safely and efficiently in the laboratory is a constantly growing challenge. Laboratories have to manufacture high-quality products and guarantee reliable, reproducible results. That's why laboratory safety solutions are not limited to personal protective equipment and adequate ventilation of the laboratory environment, but affect all areas of modern laboratory work - especially areas we generally rarely pay attention to in everyday life.

Author: Herbert Heidfeldt

Safe handling of solvents in the laboratory.

„Avoiding contamination in the laboratory is absolutely necessary to protect employees against health hazards.“



Michael Baldus

Product manager,
NOVIA Chromatographie-
und Messverfahren GmbH

*NOVIA is a company owned by
Provdia Partner für Bildung
und Beratung GmbH.*

Does this situation sound familiar?

You're in the laboratory preparing your samples, but you're still thinking about the parallel analysis you just ran and also have to remember to equilibrate your HPLC system. You lose focus for a moment and you've spilled the solvent you wanted to pour straight into the flask.

In my own experience, that's part of a normal workday in the laboratory.

This loss of attention is followed by contamination with hazardous chemicals, particularly solvents. But it isn't just inattention like this; it's also incorrect handling by insufficiently qualified and thus unsuitable laboratory equipment that leads to health and environmental hazards.

Avoiding contamination in the laboratory is absolutely necessary to protect employees against health hazards. The greatest danger for employees is to be unknowingly exposed to risk.

In order to avoid undesired physical contact with hazardous materials, laboratory personnel should observe the basic safety rules for working in the laboratory.

But they can only do so if suitable technical solutions for handling solvents are available and can be implemented.

In our experience, both the SafetyCaps for solvent extraction and the SafetyWasteCaps for safe disposal fulfil these requirements ideally.

Responsible activities in the laboratory require well-trained personnel. In doing so, the pure knowledge of occupational health and safety plays a role, especially so-called „awareness“. Only employees who are familiar with the contexts and risks contained in their work and have developed an awareness of security can act appropriately - but only if they know the necessary correct technical solutions and are able to use them.

As a company engaged in the education and training of laboratory staff, we have a high responsibility towards people to inform them about correct practices,

„S.C.A.T. Europe systems are demonstrably easy and safe to use“

necessary expertise and the correct, optimum technical solutions in theory and in practice.

We realize this by making health, safety and environmental protection an integral part of our qualification measures - whether in training, continuing education or programs of study.

All the S.C.A.T. Europe systems we implement have proven themselves to be easy and safe to use - whether it's the simple replacement of ventilation valves, the secure closure of the safety funnel with a ball valve or the flexibility provided by the multiple sizes of threaded connections and additional components.

Maximum security is always combined with user-friendliness and easy handling.

Conclusion:

In order to ensure the safe handling of solvents in the laboratory, facilities must include easily usable and reliable tools and systems, as these contribute significantly to occupational health and safety - all systems by S.C.A.T. Europe meet these requirements. They also ensure that „clean“, reproducible analysis results are obtained, since the systems avoid contamination of the solvent, even with outside impurities.

Author: Michael Baldus

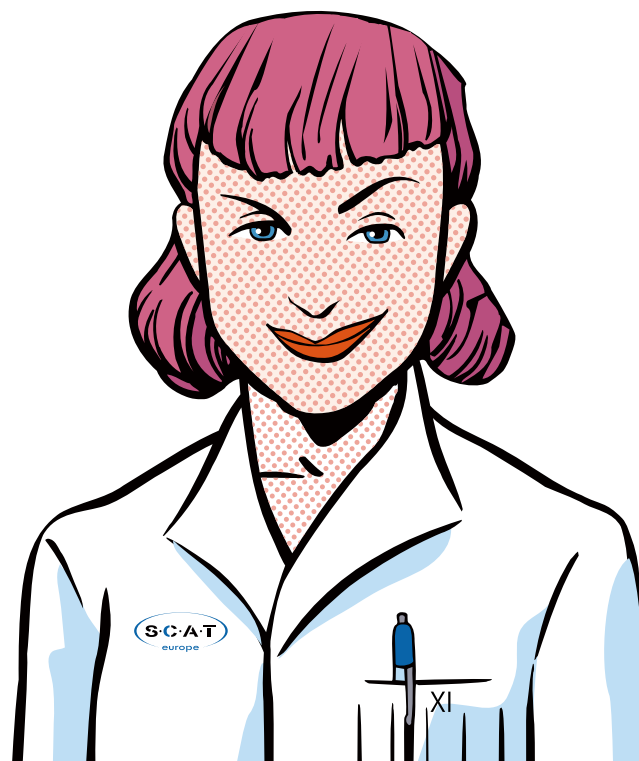

Safety every day in the laboratory.

„This clearly documents that with the S.C.A.T. SafetyCap an evident reduction in the methanol concentration in the test chamber to nearly 0 was achieved, so the workplace limit value of 270 mg/m³ specified by TRGS 900 was fallen well below.“

SGS Institut Fresenius was commissioned to investigate reduction of emissions achieved by use of S.C.A.T. SafetyCaps.



In this respect, 1000 ml solvent bottles with and without SafetyCaps were used and the emissions over a period of 28 days compared.

Then test chamber tests were conducted over a period of 7 days, during which the level of emissions in atmosphere were regularly monitored.

The solvent components tested as examples were the tested compounds methanol/water (ratio: 80/20), acetonitrile and methanol.



Additional test reports attendant to efficiency of S.C.A.T. Europe SafetyCaps can be downloaded at www.scatt-europe.com

„ ... no change in the mixture ratio was found with S.C.A.T. Europe SafetyCaps“

Determining the changes in density and volume

SGS Institut Fresenius GmbH was commissioned by S.C.A.T. Europe GmbH to evaluate the effectiveness of their S.C.A.T. SafetyCaps in comparison to a solvent bottle without S.C.A.T. SafetyCaps. Changes in density of a methanol/water mixture were examined to determine if use of the S.C.A.T. SafetyCap could prevent a change in the mixture over an longer time of 8 days. A comparison of the measured results shows that in a bottle fitted with the S.C.A.T. SafetyCap no change in density occurs, the initial

density of 0.855 g/cm^3 stayed constant throughout the entire 8 days of the test.

In contrast to this, the solvent bottle without a S.C.A.T. SafetyCap displayed a demonstrable change in density so that the initial value of 0.855 g/cm^3 of the solvent mixture rose to a density of 0.858 g/cm^3 (Fig.1). An increase in density indicates that there has been a greater loss of methanol than of water from the mixture. This loss did not occur in the same mixture ratio. Therefore a change in the composition of the methanol/

water mixture can be assumed, which then could result in errors in measured values under laboratory conditions.

In contrast to this, in the solvent bottle with the S.C.A.T. SafetyCap, no change in the mixture ratio was found so that errors in measured values due to a change in the solvent mixture can be excluded.

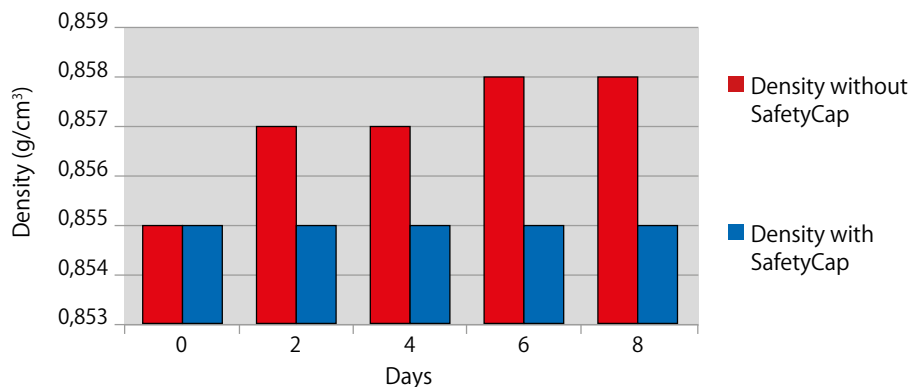

Fig. 1 Changes in the density of a methanol/water mixture

Continued on next page >

„Quality assurance measures“

S.C.A.T. Europe SafetyCaps

Characterization of the change in volume in methanol and acetonitrile

The first step in this test was to determine change in volume by means of differential weighing over the 28 day pilot study in which both acetonitrile and methanol were specified as solvents. These two solvents were used to generate the best possible comparison with real on-site conditions in a HPLC laboratory. Based on the measurement results it is evident that in both series of trials with the S.C.A.T. SafetyCap, scarcely any change in volume over the period of 28 days was observed. In comparison to this, without the S.C.A.T. SafetyCap, a significant reduction in the given volume of 1 liter was found within the period of the trial (Fig. 2).

In the acetonitrile bottle without a SafetyCap, a reduction in volume of almost 10% occurred so that after 28 days, only 90% of the initial volume remained in the solvent bottle. Consequently, after 4 weeks, almost 10% of the solvent quantity was lost, having escaped unfiltered into the atmosphere. During differential weighting to determine the change in volume of methanol, it was evident that an even more significant reduction had occurred in the solvent bottle not fitted with a S.C.A.T. SafetyCap: After 28 days, only 87.8% of the

initial volume remained in the open solvent bottle, compared with 100% of the initial volume remaining in the solvent bottle equipped with the S.C.A.T. SafetyCap. It is obvious that almost 13% of the solvent quantity used are lost, having escaped into the atmosphere from the solvent bottle not fitted with a S.C.A.T. SafetyCap.

Characterization of the atmospheric concentration by test chamber investigations

In order to investigate the atmospheric emissions caused by open solvent bottles in comparison to a solvent bottle with S.C.A.T. SafetyCap, one of each solvent bottles were placed in a test chamber and their respective methanol or acetonitrile emissions were tested after 1, 3 and 7 days (fig. 3).

It was evident that within the test chamber, despite continuous air exchange a methanol concentration of 630–660 mg/m³ could be determined for the solvent bottle without SafetyCap, whereas a concentration of 1–2 mg/m³ was analyzed for a solvent bottle with S.C.A.T. SafetyCap.

This clearly documents that with the S.C.A.T. SafetyCap an evident reduction in the methanol concentration in the test chamber to nearly 0 was achieved, so the workplace limit value of 270 mg/m³ specified by TRGS 900 was fallen well below.

In contrast to this, without SafetyCap the concentration of 630–660 mg/m³ clearly exceeds the workplace limit value to constitute a background exposure which can lead to impairment of employees' health in the laboratory.

A similar picture also results from the test chamber investigation with acetonitrile, in which a concentration of 1–5 mg/m³ was determined with SafetyCap, as opposed to an atmospheric concentration of 730–800 mg/m³ without the S.C.A.T. SafetyCap, despite continuous air exchange (Fig. 3).

Comparison of the detected test chamber emissions with the acetonitrile limit values of 34 mg/m³ specified by TRGS 900 showed that without the S.C.A.T. SafetyCap, the workplace limit value was evidently exceeded. In contrast to this, with the S.C.A.T. on the bottle a distinct minimization of the acetonitrile concentration was determined, which was well below the workplace limit value of 34 mg/m³ specified by TRGS 900 (fig. 4).

Conclusion

In conclusion, it is evident that solvent emissions could be significantly reduced by the S.C.A.T. SafetyCaps. In this respect, the use of S.C.A.T. SafetyCaps can be expected to lead to a clear reduction of the exposure to solvents in the air in a laboratory.

In this connection the reduction in the solvent concentration in the air can be assumed to be of a similar proportion as was described previously, leading to significantly lower health risk for the employees concerned.

Furthermore, S.C.A.T. technology significantly minimizes the risk of contamination of solvent-free blank samples in laboratories, so the use of S.C.A.T. SafetyCaps can also be considered a measure of quality assurance.

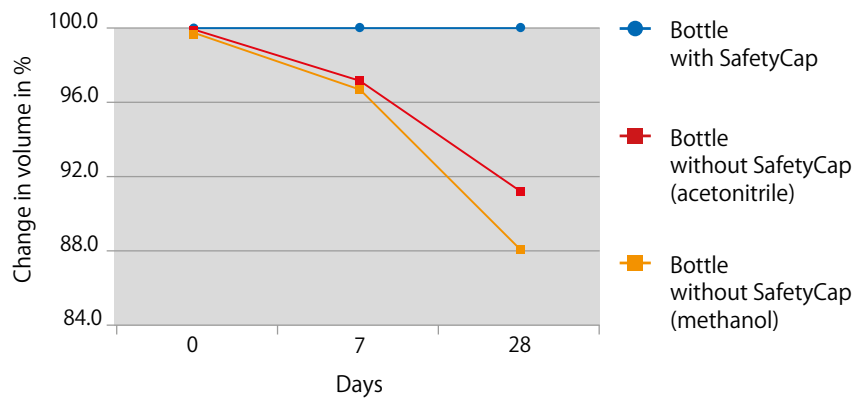

Fig. 2 Changes in volume of methanol and acetonitrile

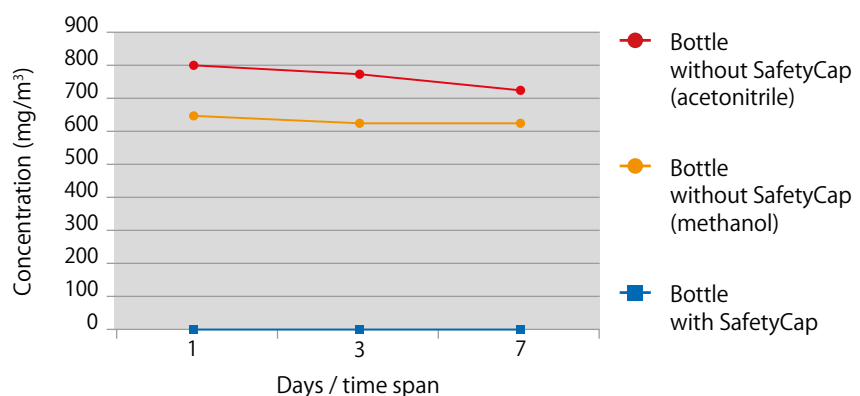

Fig. 3 Methanol emissions and acetonitrile emissions in the test chamber

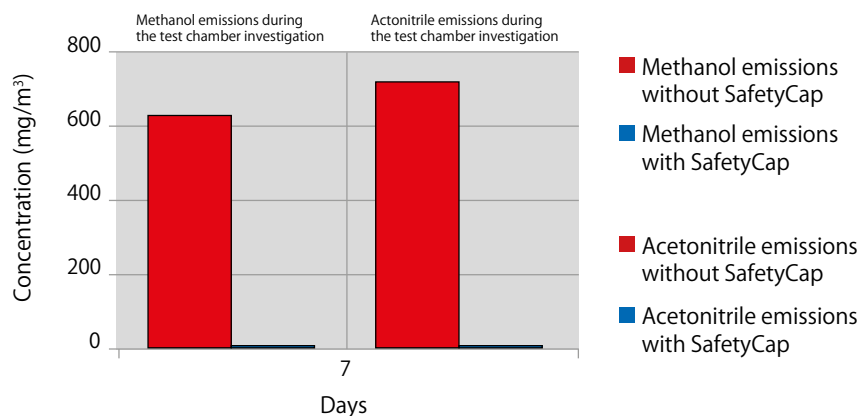

Fig. 4 Methanol emissions & acetonitrile emissions in the test chamber

When handling flammable liquids: Electrostatic risks of ignition in your laboratory?

„Alternately, the use of conductive or dissipative materials is recommended, as they can uncritically discharge their charges when grounded. This means that the prerequisite for brush discharges, the charged insulating material surfaces, is not present.“

Author: Kurt Moritz

Kurt Moritz is the specialist in charge of electrostatics and mechanical explosion protection for the technical plant safety of Merck KGaA, Darmstadt.

Contrary to popular belief, electrostatics - often called static electricity - is not produced by rubbing surfaces together but by separating surfaces which were previously in intensive contact. In this context, intensive means that a contact surface, a dwell time (even if short) and a distance between the surface of max. 10 mm must all be present.

Depending on the conductivity and position in the triboelectric series, materials tend to pick up charged particles on their surfaces or transmit charged particles to the adjacent surface. In this case, conductive materials serve as electron suppliers (donator), while insulating materials absorb charged particles (acceptor).

If the surfaces are separated quickly after such a charge transfer, and if at least one of these materials is a poor conductor of electricity, the charge transferred can no longer flow back to the surface from which it originated. These charged particles which cannot be

transferred back remain on the one surface and form a charge excess, while they are absent on the other surface, leading to a charge deficiency on that surface. When separated, voltage is generated that can rapidly reach the kV range.

Therefore, electrostatics is always a surface effect and occurs on the surface on a molecular or atomic level.

When working with solids, it is easy to recognize separation processes that may lead to charges. In general, visible movements are always present. Removing films, pouring a product out of a container, removing synthetic pieces of clothing (fleece, polyester) that are separated from the body - all these things lead to tangible and sometimes visible charges and discharges.

However, a prerequisite for charge separation is, as previously explained, that at least one of the materials involved must be a poor conductor of electricity.

Poor conductors (or „insulators“) include most plastics like PE, PVC, PVDF, PTFE, etc. However, solids are not classified by conductivity (unit: S/m) but by resistance (unit: Ωm). Siemens/metre is the reciprocal value of the ohmmeter, so the numerical values are directly comparable. Therefore, low conductivity corresponds to high resistance.

Liquids shall also be distinguished from an electrostatic standpoint, and even liquids have a high resistance - in other words, poor electrical conductivity.

These include, for example, aliphatic/aromatic hydrocarbons, such as ethers, as well as widely used solvents such as toluene, n-heptane, n-hexane, xylenes, etc.

Some nitrites (such as acetonitrile) and some esters play a special part, as they lead to unexpectedly high supercharges despite having relatively good conductivity - a previously little-known and rarely-investigated effect. This means that electrostatic

Electrostatics always a surface effect

Tribo-electric range

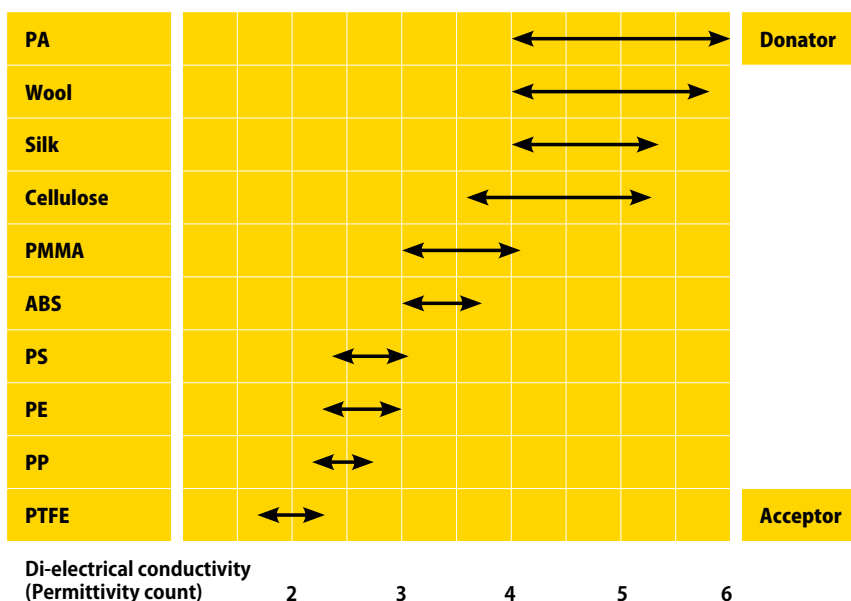

Materials with higher permittivity serve as electron suppliers (donors). Those with lower permittivity tend to accept charged particles (acceptors).

protection is especially important for such substances.

Now, unlike the solids, a surface separation process is not always recognizable as such with liquids.

The fluid-filled glass pipeline or the semi-transparent HPLC hose with its still medium is optically barely distinguishable from the pipeline with flowing medium.

And even if it is: the liquid column remains completely in contact with the inner wall of the hose/tube. **But no surfaces are separated in this process, are they?**

A common misconception, because, unlike solids, a so-called electrochemical double layer (also called a Helmholtz double layer) forms in the liquid on the container or pipeline wall with electrically charged separated layers. When the liquid flows, the charge layer that is primarily situated in the liquid is carried along.

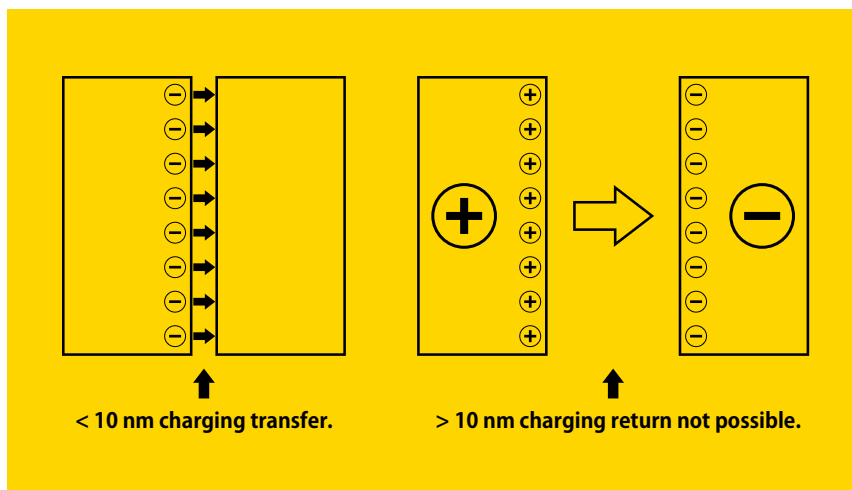

Charge transfer upon contact, charge separation by surface separation.

Continued on next page >

Most frequent type of discharge: the spark discharge

Surface roughness, flow-inhibiting installations and cross-sectional changes also favour these effects, increasing the charging for the system.

Of course certain quantities and (separating) speeds are necessary in order to generate a charging process.

When promoting in closed systems, for example, a speed of <1 m/s is designated critical because an equilibrium between charge transfer and charge reflux sets in up to this value. However, this limit is not applicable to free pouring, because different volume-to-surface conditions are present in this instance and a charge reflux is excluded by the removal of the liquid.

Therefore, filling a test tube from a laboratory spray bottle certainly does not meet the criteria that lead to critical electrostatic charges, even though the spray bottle is also made of insulating material (generally LDPE or HDPE).

However, charges can be generated if a larger quantity is conveyed at a higher speed. **This situation may occur in capillaries and hoses in HPLC systems**, for example, especially when several of these hoses are combined, concentrating and increasing the flow of waste solvents. The associated separation or charging processes can be so strong that an electrostatic field forms around the promoting hoses. Now, if conductive, non-grounded components (such as metal parts) are present within the effective range of this field, they are subject to a charge polarisation. This means that the opposing polarity increases towards the field; the like-minded polarity is repelled. This polarisation effect of charged particles in ungrounded conductive components can be so strong that a discharge of the excess charge or - depending on polarity - an equalisation of the charge defect until the next „grounding“ takes place. Both generally manifest in the form of sparks.

A classic example for charges via induction are metallic components such as couplings or brackets connected to liquid promotional hoses made of insulating material.

Even when pouring liquids which flow over surfaces and subsequently collect in containers (e.g. waste solvents that are poured through a funnel into a collection tank), charges may accumulate. Initially, the funnel may charge in one polarity due to the separation process between liquid and funnel.

The oppositely charged liquid collects in the container and transmits its charge to the container. If the funnel and container are not electrically/ electrostatically connected to each other, a different electric potential forms on both components, i.e. a charge that can be discharged in the form of sparks. This creates an ignition hazard.

Damaging incidents due to electrostatic charges and discharges when transferring liquids and waste solvents are well-known and documented.

How do you avoid electrostatic ignition hazards when handling solvents in laboratories?

There are three different types of electrostatic discharge that are relevant in laboratories. A risk assessment that takes into account these three types of discharge, evaluates them and specifies safeguards protects against electrostatic hazards.

The most common type of discharge is the spark discharge, which always occurs when conductive materials are charged by separating their surfaces from insulating materials or by „induction“.

These charged, conductive objects may include

- packaging materials such as canisters, alloy bottles, metal containers
- persons
- tools such as funnels, pipeline components, sieves and filters
- as well as flammable solvents with high conductivity (alcohols, ketones)

if their charges cannot be discharged.

The charge accumulates as if in a capacitor. If the potential is high enough, the charge is equalized with another conductive object to other potentials (generally to the grounding).

The use of conductive or dissipative grounding materials prevents spark discharges.

The charge is equalized via the ground connection and a possible charge is harmlessly discharged. At the same time, conductive, grounded containers are capable of grounding the conductive liquids they hold.

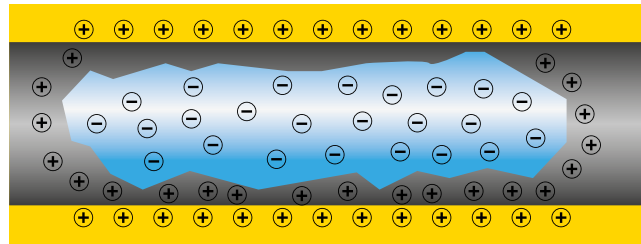

Charge separation on a molecular basis while being promoted.

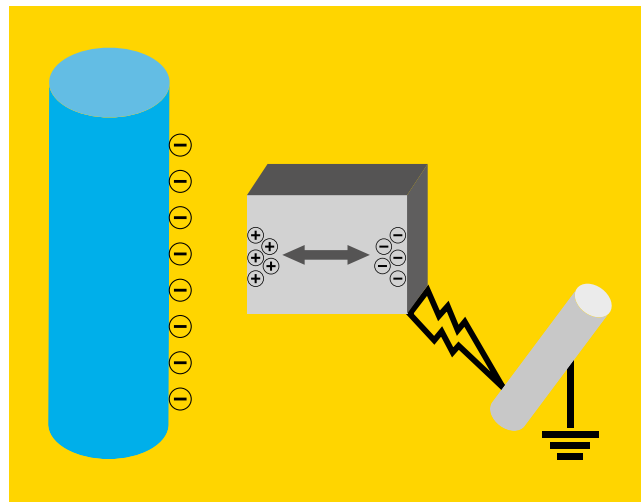

Polarisation of conductive, ungrounded parts through „induction“. This may lead to a charge equalisation via a spark discharge.

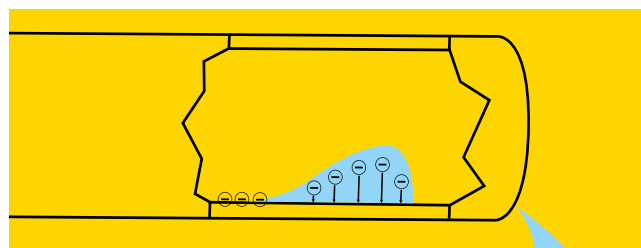

Charge separation when pouring a liquid with high conductivity (such as methanol, THF, acetonitrile) and a body of insulating material (such as PE/PTFE/etc.). Charges can also accumulate with reversed properties (conductive body and insulating liquid).

Continued on next page >

Prevent spark discharges? By using dissipative materials!

The second relevant type of discharge is the brush discharge.

This occurs on insulating surfaces which have been charged by separating operations such as rubbing, wiping, the removal of protective films, etc., or by spraying.

Insulating solid surfaces can only be charged by such surface processes. Charging via induction does not occur in insulating materials, as the poor conductivity does not allow the charged particles in the material to be moved/polarised.

If a charged insulating surface is given a grounding conductor, such as by the approach of a metal object or a person, the electrostatic field concentrates towards this grounding and develops into a spark manifesting on the surface - the brushing discharge.

Brushing discharges are lower in energy than spark discharges and cannot ignite flammable dust-air mixtures with a minimum ignition energy of > 1 mJ. However, the energy of the brush discharge is sufficient to ignite flammable solvent vapours or combustible gases.

Depending on the combustible material (e.g. the explosion group IIC) and the probability of occurrence of ignitable solvent vapour-air mixtures (such as „occasional“ / Zone 1), an insulating material surfaces >20 cm² may be evaluated as critical.

Containers such as cans, bottles, etc., or tools made of insulating materials may sometimes have a manufacturer release for use with flammable solvents; however, the operator must be aware of this hazard and must observe the manufacturer specifications and conditions of use (such as „Dry wiping prohibited“, „...only for designated use“, etc.).

To protect against brush discharges, insulating surfaces cannot be charged by rubbing, wiping, or similar operations in the simultaneous presence of flammable vapours.

Alternately, the use of conductive or dissipative materials is recommended, as they can uncritically discharge their charges when grounded. This means that the prerequisite for brush discharges, the charged insulating material surfaces, is not present.

The third type of discharge observed in laboratories is the propagating bush discharge.

This mainly occurs inside plants and on insulating surfaces if so-called „strong charge-generating processes“ take place simultaneously. For example, these conditions are present in insulating hoses through which aerosols or solid particles are promoted at high speed.

A hose affected in this manner and in which a propagating brush discharge has occurred generally has a dark mark, several centimetres long, with a central concentration, which caused a perforation in the wall due to the discharge breakdown.

A propagating brush discharge contains enough energy to ignite fuel-air mixtures of any kind. However, as several conditions are required for the creation of this type of discharge, the probability of occurrence is relatively low. If in doubt, seek an expert opinion.

Since propagating brush discharges only occur on insulating surfaces, the use of conductive or dissipative transport or conveyor systems is also an adequate safeguard in this situation.

Electrostatics and their ignition risk is a very complex issue. The requirements for components and parts used in so-called hazardous areas, i.e. zones defined as hazardous-relevant because flammable atmospheres occur frequently and to a greater extent in these areas, are heavily regulated.

Technical regulations for hazardous substances

TRGS 727

But even in areas with high air exchange and lower solvent volumes which are not defined as hazardous zones, care must be taken to ensure that no electrostatic ignition source is created near emission sites or near the open handling of solvents. An electrostatic discharge occurring in this area would inevitably cause the mixture to ignite and, in a worst-case scenario, would cause the container to explode.

This emission should initially be avoided by use of suitable filtration systems, for example. If this is not possible, care must be taken to ensure that no electrostatic hazards can be created near solvent emission sites or in areas in which these substances are handled openly (i.e. waste solvent collection points).

To this end, the previously specified safeguards for solvent systems as well as additional measures, such as the grounding of persons via dissipative flooring and appropriate footwear, must be maintained. Electrostatic requirements for the hazardous areas listed above are regulated differently depending on national regulations.

In Germany, the „Technical Regulations for Hazardous Substances“, or TRGS 727 (formerly TRBS 2153), delineates electrostatic requirements in hazardous areas under the title „Prevention of ignition hazards due to electrostatic charge“.

At the European level, CENELEC (EUROPEAN COMMITTEE FOR ELECTROTECHNICAL STANDARDIZATION) CLC/TR 50404:2003 superseded by CLC/TR 60079-32-1:2015 Electrostatics - Code of practice for the avoidance of hazards due to static electricity is applied.

These regulations describe hazards and specify safety measures. Therefore, their contents can also be applied here as a source of useful information and can be used in the event of questions.

Kurt Moritz

Kurt Moritz is the specialist in charge of electrostatics and mechanical explosion protection for the technical plant safety of **Merck KGaA, Darmstadt**.



The safe grounding of conductive components prevents spark discharges. Conductive materials must also be grounded.



Using conductive or dissipative grounding materials avoids creating insulating surfaces. This removes the prerequisite for brush discharges.

Protect your health.

Hazardous vapours may arise while working with solvents and other hazardous liquids. Inadequate sealing of supply or waste containers creates health risks. Numerous statutory guidelines apply. Always put your own health first.

In addition to the Chemicals Act, the Hazardous Substances Act is based on the Occupational Health and Safety Act. The employer is responsible for protecting all workers against risks to health through inhalation, skin contact and the physico-chemical effects of hazardous substances.

S.C.A.T. Europe supports enterprises with consultation and can offer standard as well as customized solutions for all areas.

In January 2009, regulation (EC) no. 1272/2008 – the CLP Regulation - entered into effect.

It regulates the classification, labelling and packaging of substances and mixtures (Regulation on classification, labelling and packaging of substances and mixtures, or CLP) and replaced the European Dangerous Substances Directive and the Dangerous Preparations Directive in 2015.

The CLP Regulation is based on a UN recommendation to introduce a uniform system for the classification and labelling of chemicals (Globally Harmonised System, UN GHS), which dates back to the 1992 Sustainability Conference in Rio de Janeiro. This represents a compromise between established systems, primarily between North America, the EU and the regulations on hazardous goods.

Source:
Bundesanstalt für Arbeitsschutz und Arbeitsmedizin (BAuA)

For more information, please visit:
www.unece.org



European list of agents that trigger (occupational) diseases (Extract from BKV Annex 1, December 2014. Source: BAuA)

Lead or its compounds • mercury or its compounds • chromium or its compounds • cadmium or its compounds • manganese or its compounds • thallium or its compounds • vanadium or its compounds • arsenic or its compounds • phosphorus or its inorganic compounds • beryllium or its compounds • carbon monoxide • hydrogen sulphide • mucosal lesions, cancer or other neoplasms of the urinary tract by aromatic amines • halocarbons • benzene, its homologues or styrene • nitro or amino compounds of benzene or its homologues • carbon disulfide • methyl alcohol (methanol) • organic phosphorus compounds • fluorine or its compounds • nitric esters • halogenated alkyl, aryl or alkylaryl oxide • halogenated alkyl, aryl or alkyl aryl sulphide • diseases of the teeth by acids • corneal damage to the eye by benzoquinone • para-tertiary butyl phenol • isocyanate • liver disease by dimethylformamide • polyneuropathy or encephalopathy caused by organic solvents or mixtures thereof • diseases of the blood, the blood-forming and the lymphatic system by benzene • cancer of the larynx by sulphuric acid-containing aerosols (...)

TRGS 526 „Laboratories“ (Technical regulations for hazardous substances)

2 / General information:

Laboratories must (...) be designed and operated according to prior art standards.

3.1 / Risk assessment - Procedure:

Measures to protect against hazardous substances shall be set so that (...) the employees are not exposed to any hazards or loads. If this is not possible, the activity should be designed so that the overall risk to workers is minimized after reviewing alternate measures.

3.3.1 / Exposure assessment:

The employer can generally assume that no unacceptably high exposure to hazardous substances is present if expert (...) personnel is acting in accordance with relevant regulations and prior art (...).

3.7 / Employment restrictions:

Employment restrictions for minors, women of childbearing age, and pregnant and lactating women must be observed (Young Persons Employment Act, Maternity Protection Act and the regulation for the protection of mothers in the workplace).

4.3.1 / Avoiding hazards:

The employer shall design the workplace to avoid hazards or reduce them to a minimum. The duration and extent of exposure to hazardous substances must be limited, (...).

4.11.1 / Release of gases and vapours:

Outside of fume hoods, activities in which gases and vapours may form in hazardous concentrations or quantities may only be performed if suitable safeguards (...) ensure that a threat (...) is excluded.

4.16.1 / Handling waste:

When preparing and filling storage tanks (of waste), no hazardous gases or vapours (...) may leak or otherwise enter into the laboratory air.

5.2.23 / Chromatography (HPLC):

If the system cannot be operated with a fume hood, the released solvent vapours must be vented/dissipated safely.

6.1 / Technical protective measures:

Hazards in laboratories are primarily avoided by ensuring that workplaces are appropriately designed and equipped. These include (...) the nature of the equipment, instruments and (...).

TRBS 2153 - Avoiding ignition hazards due to electrostatic charges (Technical regulations for operating safety) (See also TRGS 727)

4.5 Electrostatic charges when handling liquids - small containers

(...) Dangerous charges can be generated by friction, fluid flow or ungrounded persons. In these cases, hazardous discharges to insulated metal components, such as handles, locks, barrel pumps or solid/liquid surfaces, should be expected.

4.5.1 Conductive or dissipative containers

While filling and emptying the container, all conductive or dissipative parts of the system must be electrically connected and grounded.



S.C.A.T. Europe Icons

We have developed these icons to make it even easier for you to navigate through this catalog. This way, you can quickly and easily compare products and their features. S.C.A.T. is the solid brand and your companion for safety in the laboratory.

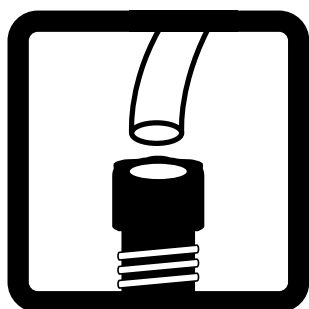

Connection options
for HPLC capillaries



Connection options
for tubing

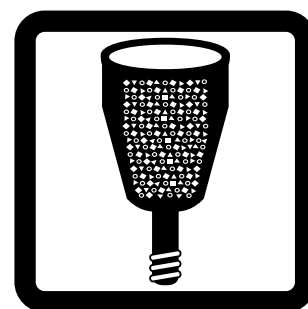

Connection options
for S.C.A.T. Exhaust
filters

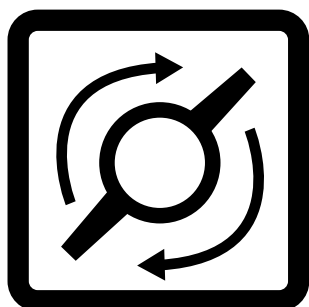

Integrated safety
funnels with shut-off

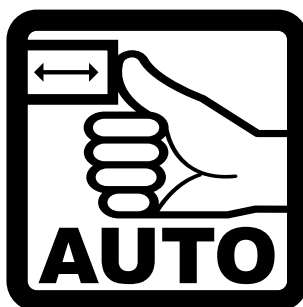

Integrated safety
funnels with automatic
closure

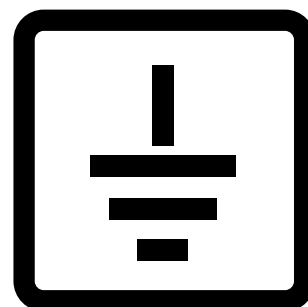

Connection options
for ground cables

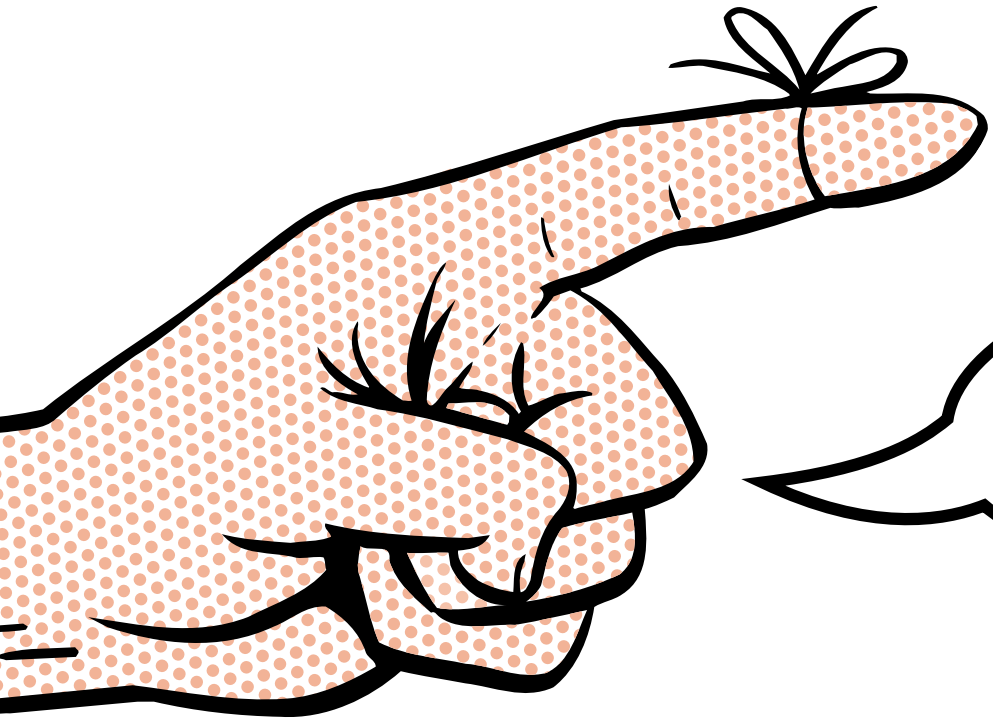

**WHAT A NICE
MEMORY AID!**

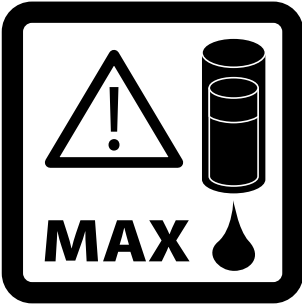

Integrated floater
for level warning

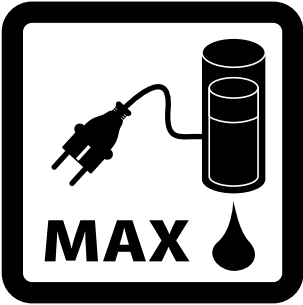

Connection options for
electronic level control

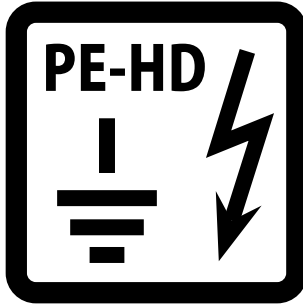

Electrostatic conductive PE-HD to prevent
from ignition risks



Service life / lifespan
for consumables

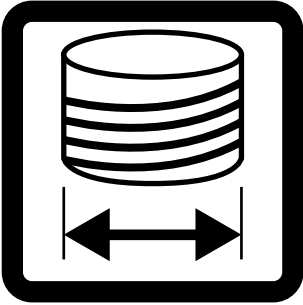

Thread size



UN approval for the
transport of hazardous
goods on roads and
plant premises

Safety Solutions Contents

EXTRACTION SYSTEMS - SafetyCaps



WASTE SYSTEMS - SafetyWasteCaps



SAFETY FUNNELS



LEVEL CONTROL

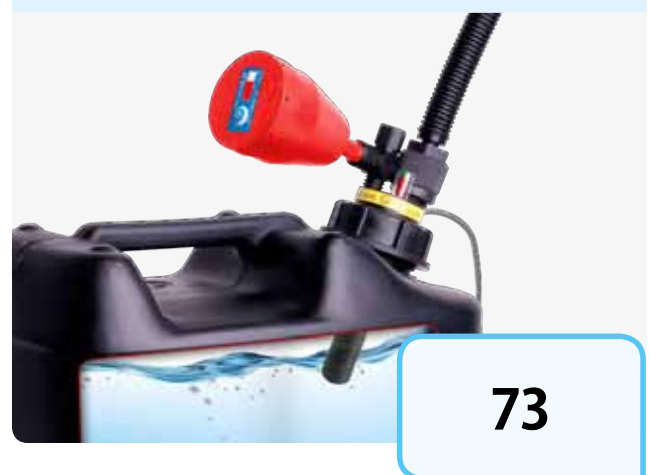

CONTAINERS

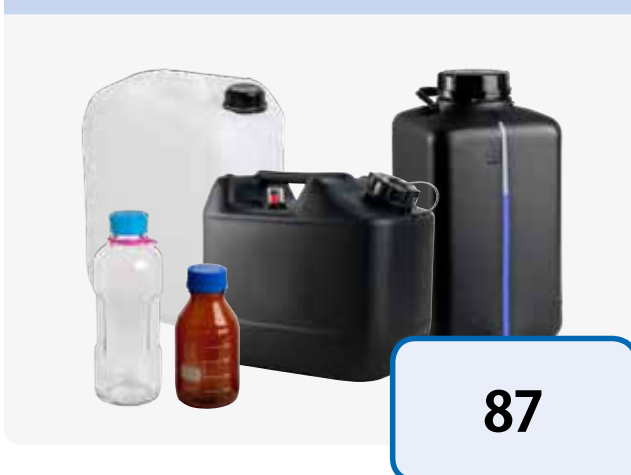

ACCESSORIES



S.C.A.T. Europe Safety Solutions 2016/2017 Quickfinder

Chapter register tabs and page number

EXTRACTION SYSTEMS - SafetyCaps - Air valves

1

WASTE SYSTEMS - SafetyWasteCaps - Exhaust filters

25

SAFETY FUNNELS - with ball valve - with hinged lid

63

LEVEL CONTROL - Electronic signal boxes - Canisters with integrated level control

73

CONTAINERS - Laboratory bottles - Canisters - Spouts - Collecting trays

87

ACCESSORIES - Air valves - Exhaust filters - Fittings - Tube fittings - Adapters - Connectors and many more...

99

LABORATORY INSTALLATION

SymLine[®]
Chemical Waste Systems

SymLine[®] is a brand of



Missing the chapter LABORATORY INSTALLATION?

S.C.A.T. Europe's skillful built-in-solutions are now called **SymLine[®]**. Visit www.SymLine.de



Extraction systems

How do you extract your solvents?

The first and foremost concern is chromatography and secondly, safe handling of solvents is taken into consideration. It is remarkable how little attention is given to one's own health protection. Everyone who works in the laboratory should be aware of the high level risk potential through hazardous solvent vapors. There are still numerous risky types of closures for solvent bottles in use.

The inadequate handling during extraction of solvents also has consequences on your work results. The extraction capillaries can slide out of the solvent bottle because they are not screwed on tightly. This can cause air to be sucked in and HPLC equipment down times are thus "permanently calculated."

In addition, the mobile phase gets contaminated by dust particles in the air. Similarly, evaporation loss of light volatile solvents can occur and change the mixing ratio of solvent compounds - so the results are distorted. This plays a particular role with UHPLC. Solvent filtration and precisely prepared mobile solvents, with constant mixing ratios throughout the entire term, are a must with UHPLC!

In addition, solvent exchange with common screw caps is difficult to handle. Often, the well-known "tangled capillaries" occur, when supply bottles have to be exchanged.

**Trust the market leader:
S.C.A.T. - SafetyCaps are THE safety solution!**





Conventional closures endanger your health and the success of your work



Safe extraction - reliable results



Extraction systems

Technology of SafetyCaps

The new, improved air valve combines valve and filter functions. As usual, ventilation occurs during extraction; harmful solvent vapors are blocked. At the same time, the valve membrane absorbs dust and contaminant particles from the incoming air. The valve also fits your existing S.C.A.T SafetyCaps without any technical modification.

Capillary

Air valve

Fittings

PTFE body
360° freely rotatable

Change-advice-label

Screw cap

- » No more harmful vapors thanks to the integrated air valve.
- » Confidence during audits
With S.C.A.T. systems, you pass quality and safety inspections with confidence.
- » Easy container changes thanks to freely rotatable cap even with capillaries installed.
Without twisting or "tangled capillaries".

- » Change every 6 months
Since the filter membrane absorbs contaminants from the surrounding air, it is necessary that the valve be replaced every 6 months in order to ensure flawless operation.



The air valve ensures pressure equalisation during the extraction

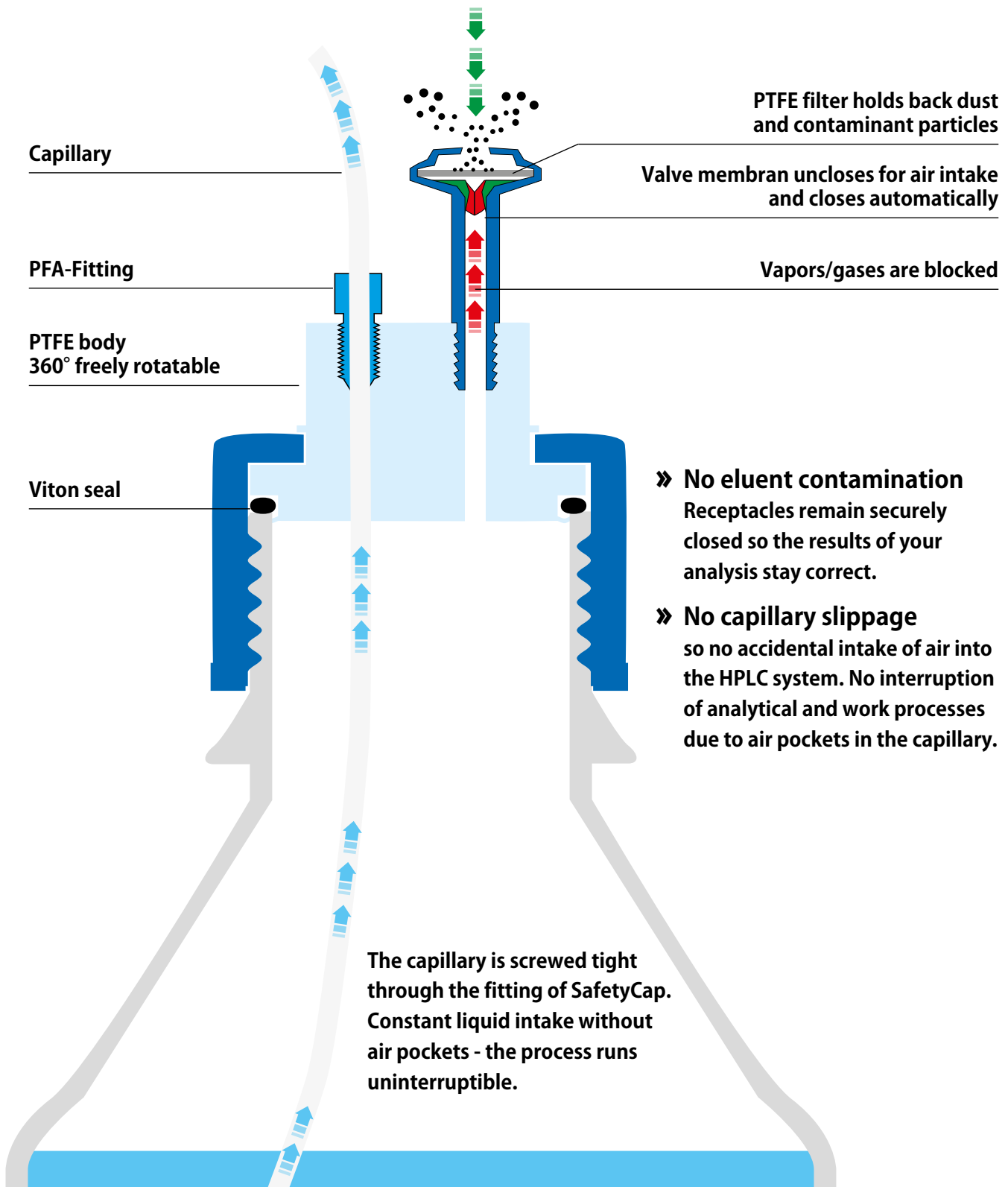

SafetyCaps Thread GL 45

EXTRACTION SYSTEMS

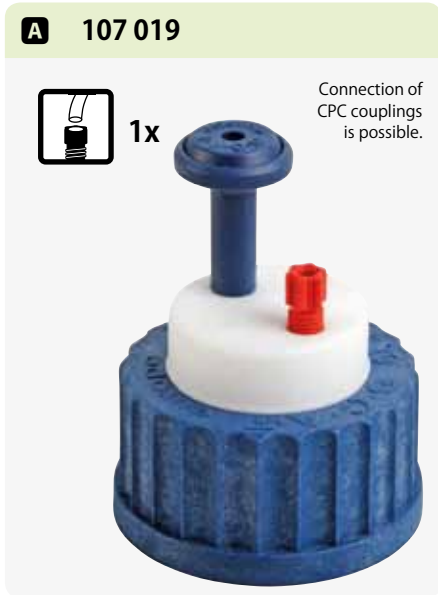

What is included in the scope of delivery?

The shown pictures accord to the scope of delivery.

The air valve with writable change-advice-label and fittings are included.



Easy to install

Thanks to the freely-rotatable cap there are no twistet or tangled capillaries. The PTFE-body stays in position - the change of solvent bottles has never been easier!



Change every 6 months

Since the filter membrane absorbs contaminants from the surrounding air, it is necessary that the valve be replaced every 6 months in order to ensure flawless operation.

GL 45 SafetyCap



Inclined!
SafetyCaps with more than 3 connectors have an inclined body, for barrier-free installation of CPC quick disconnect couplings. (Accessories on page 112.)

D 107 410

 **4x** Connection of CPC couplings is possible.



E 107 520

 **6x** Connection of CPC couplings is possible.



F 117 010

 **6 Months**



Up to 150 ml/min.

G 197 010 Stock!

 **6 Months**

10 x



Up to 150 ml/min.



H 160 501

Easily close of unused connectors.

10 x



Blind plug

Fig.	Part No.	Description	 Thread size	 Connector Ø 3.2 mm OD
A	107 019	SafetyCap I	GL 45	1x
B	107 909	SafetyCap II	GL 45	2x
C	107 910	SafetyCap III	GL 45	3x
D	107 410	SafetyCap IV	GL 45	4x
E	107 520	SafetyCap VI	GL 45	6x
F	117 010	Air valve for SafetyCaps	UNF 1/4" 28G	-
G	197 010	Air valve for SafetyCaps (10 pc./unit)	UNF 1/4" 28G	-
H	160 501	Blind plug (10 pc./unit)	UNF 1/4" 28G	-

SafetyCaps Thread GL 45 for the preparative HPLC

EXTRACTION SYSTEMS

A 107 007



1x



B 107 008



2x



C 107 009



2x



D 109 032



2x



E 110 032



3x



» Connectors for larger extraction tubes with up to \varnothing 6.35 mm outer diameter.

What is included in the scope of delivery?

The shown pictures accord to the scope of delivery.

The air valve with change-advice-label and fittings are included.

F 117 011



6 Months



Up to 400 ml/min.



No halfway measures!

The red air valve is specially designed for preparative HPLC operation and easily delivers supply amount of up to 400 ml/min (Blue air valve up to 150 ml/min). The connectors have a correspondingly larger diameter for typical tube sizes in the preparative HPLC. For special applications, individual **connectors can be closed with blind plugs (Page 105)**. We would also be happy to produce individual solutions for you.

Change every 6 months

Since the filter membrane absorbs contaminants from the surrounding air, it is necessary that the valve be replaced every 6 months in order to ensure flawless operation.

Fig.	Part No.	Description	Thread size	Connector Ø 3.2 mm OD (1/8")	Connector Ø 4.76 mm OD (3/16")	Connector Ø 6.35 mm OD (1/4")
A	107 007	SafetyCap I (1/4")	GL 45	-	-	1x
B	107 008	SafetyCap II (1/4")	GL 45	-	-	2x
C	107 009	SafetyCap II (1/8" + 1/4")	GL 45	1x	-	1x
-	108 032	SafetyCap I (3/16")	GL 45	-	1x	-
D	109 032	SafetyCap II (3/16")	GL 45	-	2x	-
E	110 032	SafetyCap III (3/16")	GL 45	-	3x	-
F	117 011	Air valve (preparative) up to 400ml/min.	UNF 1/4" 28G			

Fittings for capillary sizes with up to Ø 6.35 mm outer diameter

				↑ Connector	↑ Connector	↑ Connector
-	107 064	PFA Fitting 3.2 mm Ø (1/8")	UNF 1/4" 28G	↑	-	-
-	107 047	PTFE Fitting 4.00 mm Ø	UNF 5/16" -24	-	↑	-
-	107 045	PTFE Fitting 4.76 mm Ø (3/16")	UNF 5/16" -24	-	↑	-
-	107 046	PTFE Fitting 6.00 mm Ø	NPT 1/8"	-	-	↑
-	107 044	PTFE Fitting 6.35 mm Ø (1/4")	NPT 1/8"	-	-	↑

SafetyCaps Thread GL 45 with shut-off

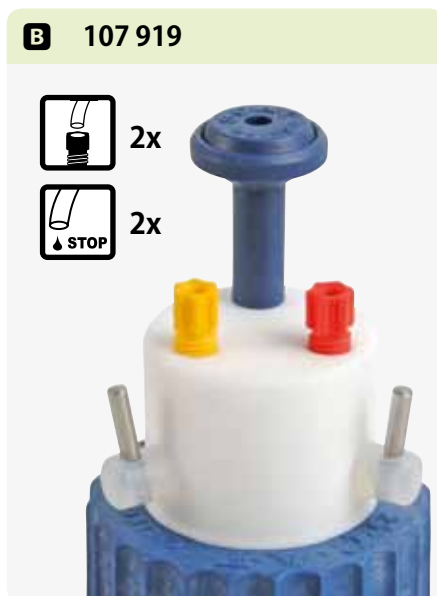

Simplified change of bottles

No air entrapment in capillaries

After the supply container is changed, the current analysis can be continued without interruption.

Ready for use again - quickly

During repairs on HPLC pumps, the shut-off on the SafetyCaps can be closed so the capillaries and solvent filter remain in the solvent. Thus the pump can be quickly and easily flushed when returning to operation after repairs.



GL 45 with shut-off

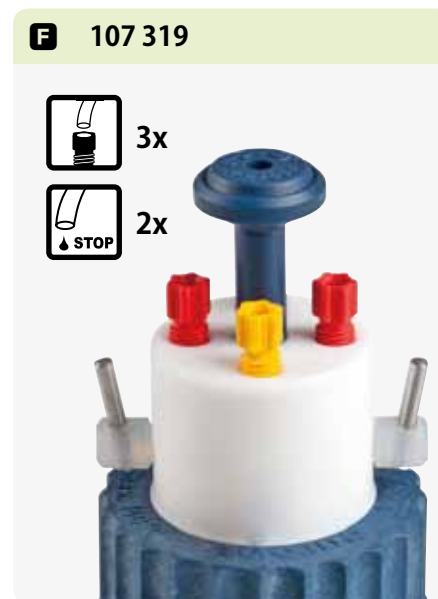
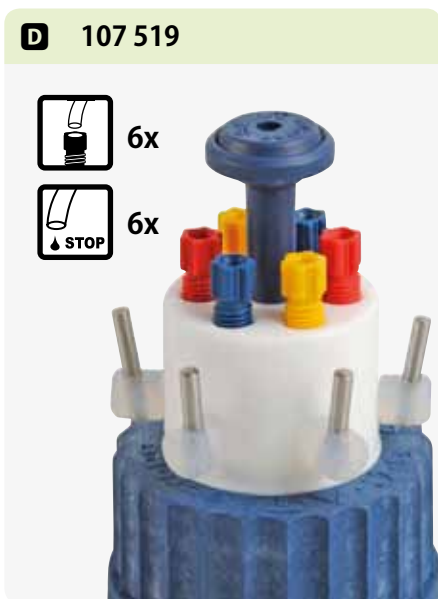

Fig.	Part No.	Description	Thread size	Connector Ø 3.2 mm OD	of which with shut-off
A	107 119	SafetyCap I with shut-off	GL 45	1x	1x
B	107 919	SafetyCap II with shut-off	GL 45	2x	2x
C	107 920	SafetyCap III with shut-off	GL 45	3x	3x
D	107 519	SafetyCap VI with shut-off	GL 45	6x	6x
E	107 219	SafetyCap II with shut-off (combined)	GL 45	2x	1x
F	107 319	SafetyCap III with shut-off (combined)	GL 45	3x	2x
G	117 010	Air valve for SafetyCaps	UNF 1/4" 28G	-	-
H	197 010	Air valve for SafetyCaps (10 pc./unit)	UNF 1/4" 28G	-	-

SafetyCaps Thread GL 45 – angled



At a squeeze!

Space-saving!

Especially where laboratory space is limited, you gain a major advantage with our angled SafetyCaps. Even when extraction bottles are stored above the HPLC system, you can easily reach all the connectors because they are attached on the side.

A 199 019



B 199 909



C 117 010



Up to 150 ml/min.



D 160 501

Easily close of unused connectors.

10 x



Blind plug

Fig.	Part No.	Description	 Thread size	 Connector Ø 3.2 mm OD
A	199 019	SafetyCap I (angled)	GL 45	1x
B	199 909	SafetyCap II (angled)	GL 45	2x
C	117 010	Air valve for SafetyCaps	UNF 1/4" 28G	-
D	160 501	Blind plug (10 pc./unit)	UNF 1/4" 28G	-

SafetyCaps for ground neck bottles





Simple loosening & opening with the locknut

Everybody is familiar with stuck ground neck stoppers: Dried fluids and sticky substances build up on the ground glass; the stopper will not budge.

S.C.A.T. closures with locknut allow the stopper to be easily loosened and removed, even after long usage.



Fig.	Part No.	Description	 Thread size	 Connector Ø 3.2mm OD
A	107 607	SafetyCap II for ground neck bottles (with locknut)	Ground neck 29/32 mm	2x
B	107 507	Blind plug for ground neck bottles (with locknut)	Ground neck 29/32 mm	-
C	107 508	Ground neck adapter for GL 45 threaded bottles	Top: Ground neck 29/32 mm (f) Bottom: GL 45 (f)	-
D	107 509	GL 45 adapter for ground neck bottles	Top: GL 45 (m) Bottom: Ground neck 29/32 mm (m)	-
E	107 506	Replacement locknuts for SafetyCaps	Ground neck 29/32 mm	-
F	117 010	Air valve for SafetyCaps	UNF 1/4" 28G	-

SafetyCaps Special threads

A 107 005



1x



GL 28

B 107 006



2x



GL 28

C 107 100



1x



S 40 / GL 40

D 107 101



2x



S 40 / GL 40

E 107 105



1x



1x



S 40 / GL 40

Thread S 40



Now you can use our proven safety system without an adapter, directly on supply bottles with thread sizes S 40 and GL 40. Many solvents are already delivered in such containers. With the new sealing system, you can connect the containers directly to the HPLC system, without decanting or thread adapters.





Include the suitable container to your order

The chapter "containers", starting from page 87, shows all suitable canisters and lab bottles for SafetyCaps.

Fig.	Part No.	Description	 Thread size	 Connector Ø 3.2 mm OD	 of which with shut-off
A	107 005	SafetyCap I (GL 28)	GL 28	1x	-
B	107 006	SafetyCap II (GL 28)	GL 28	2x	-
-	107 512	SafetyCap III (GL 38)	GL 38	3x	-
C	107 100	SafetyCap I (S 40)	S 40 / GL 40	1x	-
D	107 101	SafetyCap II (S 40)	S 40 / GL 40	2x	-
-	107 742	SafetyCap III (S 40)	S 40 / GL 40	3x	-
E	107 105	SafetyCap I (S 40) with shut-off	S 40 / GL 40	1x	1x
-	107 030	SafetyCap I (GLS 80)	GLS 80	1x	-
-	107 031	SafetyCap II (GLS 80)	GLS 80	2x	-
F	107 032	SafetyCap III (GLS 80)	GLS 80	3x	-
G	107 035	SafetyCap IV (B 83)	B 83	4x	-

SafetyCaps HPLC sets with bottle

EXTRACTION SYSTEMS

A 107 300



B 107 312



C 107 345



D 107 363





Plug and play - easy, quick and safe!

The S.C.A.T. extraction systems as complete set delivered directly to your lab. You only need one single article number for the comprehensive safety system. There is no time-consuming compilation of configurations necessary.

- » The extraction system in a complete set, ready to connect.
- » Only one article number for the comprehensive safety system.
- » No time-consuming compilation of a configuration.
- » The delivery is made complete and can be used immediately.

What is included in the scope of delivery?

The shown pictures accord to the scope of delivery.
Glass bottle, SafetyCap, fittings, air valve, PTFE suction filter and 1.5 m capillaries for each connector.

Fig.	Part No.	Description	 Connections incl. 1.5 m capillary Ø 3.2 mm OD	 of which with shut-off	Suction filter (PTFE)	Bottle	Form	Volume
A	107 300	SafetySet HPLC	1x	-	1x	DURAN® clear glass	round	1 liter
-	107 303	SafetySet HPLC	2x	-	2x	DURAN® clear glass	round	1 liter
-	107 304	SafetySet HPLC	3x	-	3x	DURAN® clear glass	round	1 liter
-	107 348	SafetySet HPLC	1x	1x	1x	DURAN® clear glass	round	1 liter
-	107 349	SafetySet HPLC	2x	2x	2x	DURAN® clear glass	round	1 liter
B	107 312	SafetySet HPLC	1x	-	1x	DURAN® brown glass	round	1 liter
-	107 313	SafetySet HPLC	2x	-	2x	DURAN® brown glass	round	1 liter
-	107 314	SafetySet HPLC	3x	-	3x	DURAN® brown glass	round	1 liter
-	107 353	SafetySet HPLC	1x	1x	1x	DURAN® brown glass	round	1 liter
-	107 354	SafetySet HPLC	2x	2x	2x	DURAN® brown glass	round	1 liter
C	107 345	SafetySet HPLC	1x	-	1x	DURAN® YOUTILITY	ergo	1 liter
-	107 346	SafetySet HPLC	2x	-	2x	DURAN® YOUTILITY	ergo	1 liter
-	107 347	SafetySet HPLC	3x	-	3x	DURAN® YOUTILITY	ergo	1 liter
-	107 362	SafetySet HPLC	1x	1x	1x	DURAN® YOUTILITY	ergo	1 liter
D	107 363	SafetySet HPLC	2x	2x	2x	DURAN® YOUTILITY	ergo	1 liter

SafetyCaps HPLC Starter Kits

EXTRACTION SYSTEMS



Initial equipment for your HPLC system - Safe extraction of solvents.

- » Price advantage compared to ordering piece by piece.
- » Suitable for all current HPLC systems.
- » Unused connectors can be closed by the blind screws delivered with the set. This makes the system universally applicable, even when less connectors are needed for a time.



Fig.	Part No.	Description	Content
A	199 200	HPLC Starter Kit 1	3x SafetyCap I (107 019) 1x SafetyCap II (107 909) 1x Blind plug (160 501) (10 pc./unit)
B	199 201	HPLC Starter Kit 2	4x SafetyCap II (107 909) 4x Blind plug (160 501) (10 pc./unit)
C	199 210	HPLC Starter Kit 3 (fire-resistant)	3x SafetyCap I fire-resistant (112 019) 1x SafetyCap II fire-resistant (112 909) 1x Blind plug (160 501) (10 pc./unit)

SafetyCaps HPLC Safety Set

EXTRACTION SYSTEMS

A 107 337



HPLC system, capillaries and the tube are not included in the scope of delivery.

- » One single set for solvent supply and waste.
- » 107 337 - One part no. for the complete set.
- » For use with all HPLC systems.

Fig.	Part No.	Description	Content
A	107 337	HPLC Safety Set	See page 20

HPLC Safety Set includes

<p>107 910</p> <p>SafetyCap III GL 45</p>  <p>4x</p>	<p>117 010</p> <p>Air valve*</p>  <p>(4x)*</p>	<p>501 113</p> <p>Laboratory bottle 1 liter GL 45 Clear glass</p>  <p>4x</p>	<p>160 501</p> <p>Blind plug for capillary connection PU = 10</p>  <p>1x</p>
<p>108 921</p> <p>SafetyWasteCap GL 45</p>  <p>1x</p>	<p>117 808</p> <p>Tube fitting, curved 6.4 - 9 mm</p>  <p>1x</p>	<p>117 816</p> <p>Tube fitting, straight 6 - 8 mm</p>  <p>2x</p>	<p>107 810</p> <p>Tube fitting, angled 9.5 - 10 mm</p>  <p>1x</p>
<p>610 535</p> <p>Exhaust filter size M</p>  <p>1x</p>	<p>107 951</p> <p>Canister 5 liter GL 45 PE-HD</p>  <p>1x</p>	<p>107 062</p> <p>Fitting Ø 2.3 mm grey PU = 5</p>  <p>1x</p>	<p>107 063</p> <p>Fitting Ø 3.2 mm blue PU = 5</p>  <p>1x</p>
<p>107 064</p> <p>Fitting Ø 3.2 mm red PU = 5</p>  <p>1x</p>	<p>107 065</p> <p>Fitting Ø 3.2 mm yellow PU = 5</p>  <p>1x</p>	<p>107 061</p> <p>Fitting Ø 1.6 mm green PU = 5</p>  <p>1x</p>	<p>* Concerning to the air valve, part number 117 010. This part number stands for individual orders and re-orders. The air valves are already included in the scope of delivery of the 4 SafetyCaps or rather included in this complete set.</p> <p>PU = Packaging Unit</p>

SafetyCaps made from fire-resistant material



Self-extinguishing

In case of fire, the worldwide unique flame protection material is an insulating layer acting to brake heat. The foaming mass prevents oxygen supply and therefore the spread of flames.

Optimal protection

Naturally the closures offer all the proven S.C.A.T. quality features to protect the user and the environment. The air valve blocks combustible solvent vapors and cleans dust and contaminant particles from the incoming air.

All limit values were fallen well below

During tests in the firing chamber, SafetyCaps attained the highest fire class V0 and were significantly below all UL-94 test criteria.

Fig.	Part No.	Description	Thread size	Connectors Ø 3.2 mm OD (1/8")	Connectors Ø 4.76 mm OD (3/16")	Connectors Ø 6.35 mm OD (1/4")
A	112 019	SafetyCap I (fire-resistant)	GL 45	1x	-	-
-	112 909	SafetyCap II (fire-resistant)	GL 45	2x	-	-
-	112 910	SafetyCap III (fire-resistant)	GL 45	3x	-	-
-	112 410	SafetyCap IV (fire-resistant)	GL 45	4x	-	-
B	112 520	SafetyCap VI (fire-resistant)	GL 45	6x	-	-
-	112 112	SafetyCap I (fire-resistant) 3/16"	GL 45	-	1x	-
-	112 212	SafetyCap II (fire-resistant) 3/16"	GL 45	-	2x	-
C	112 312	SafetyCap III (fire-resistant) 3/16"	GL 45	-	3x	-
-	112 007	SafetyCap I (fire-resistant) 1/4"	GL 45	-	-	1x
-	112 008	SafetyCap II (fire-resistant) 1/4"	GL 45	-	-	2x
-	112 009	SafetyCap II (fire-resistant) 1/4" + 1/8"	GL 45	1x	-	1x

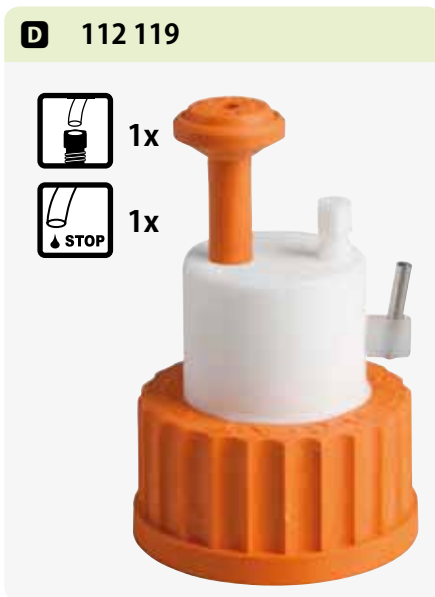

Change every 6 months

Since the filter membrane absorbs contaminants from the surrounding air, it is necessary that the valve be replaced every 6 months in order to ensure flawless operation.



Fig.	Part No.	Description	Thread size	Connectors Ø 3.2 mm OD	of which with shut-off
D	112 119	SafetyCap I (fire-resistant) with shut-off	GL 45	1x	1x
-	112 919	SafetyCap II (fire-resistant) with shut-off	GL 45	2x	2x
-	112 920	SafetyCap III (fire-resistant) with shut-off	GL 45	3x	3x
-	112 419	SafetyCap IV (fire-resistant) with shut-off	GL 45	4x	4x
-	112 519	SafetyCap VI (fire-resistant) with shut-off	GL 45	6x	6x
-	112 219	SafetyCap II (fire-resistant) with shut-off (combined)	GL 45	2x	1x
-	112 319	SafetyCap III (fire-resistant) with shut-off (combined)	GL 45	3x	2x
E	112 010	Air valve (fire-resistant) for SafetyCaps	UNF 1/4" 28G	-	-

Fire-resistant

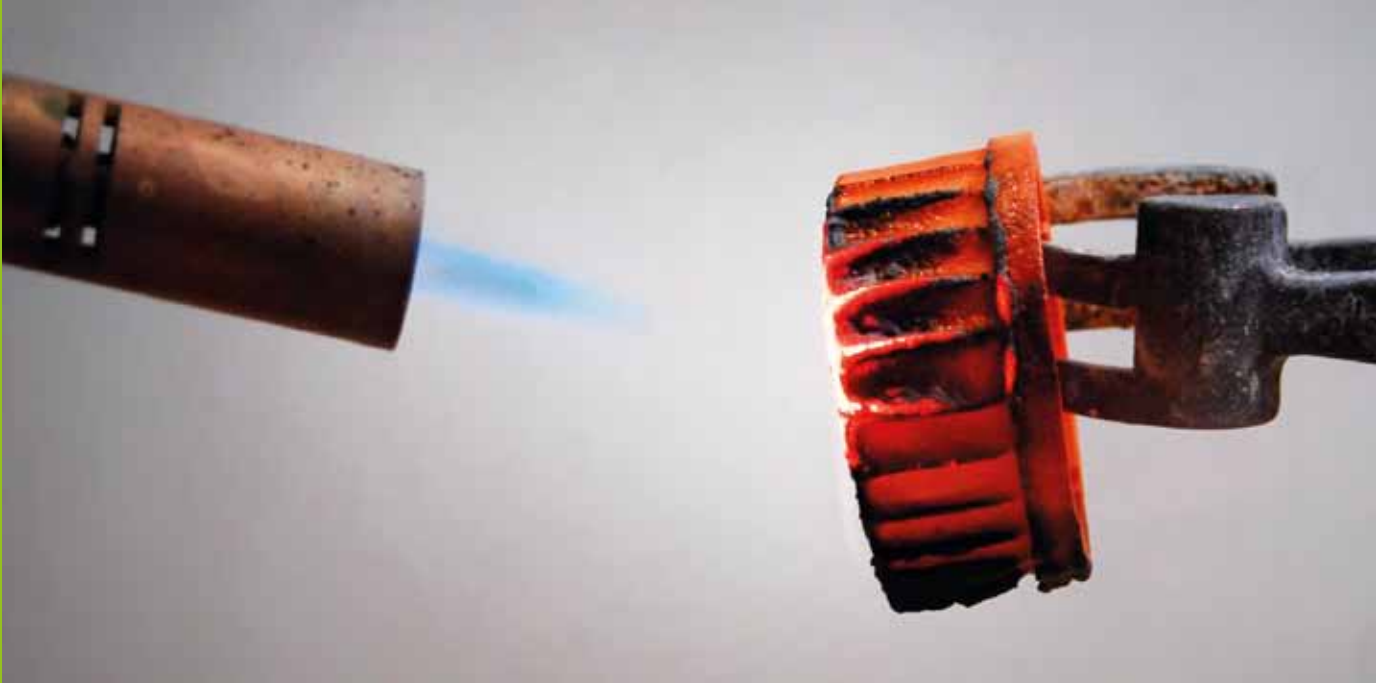

In order to assess burning characteristics, Underwriters Laboratories Inc. (USA), the most significant and internationally recognized test organization in the USA, has developed the UL-94 test as standard.

The flammability of polymer materials was subject to UL-94 and other tests. Here, V0 is the highest and best ranked fire class.

Fire resistant S.C.A.T. Products were exposed to flame under standardized test conditions while easily combustible material (e.g. cotton batting) was placed beneath the test sample. Whether or not the cotton was ignited by drips of burning material was observed.

The test series was conducted with both the closure caps and the filter housings of the SafetyWasteCaps.

The decisive criteria was flame persistence time between removal of the burner and extinguishing of the sample. To attain the ranking V0, the cotton must not be ignited and the flame persistence duration for each exposure to flame must be less than 10 seconds.

On all samples, the flame persistence times of 2 or 3 seconds were very low and well below the limit values. No drips fell from the sample in any of the tests and the cotton batting was never ignited.

Under extreme load, the samples of the covers exhibited only a slight glow and a good surface intumescence. Even at higher energies, none of the flames had an affect on the test sample.

In addition, none of the samples sustained interior damage at the places the flame was applied to.

Self-extinguishing

In case of fire, the worldwide unique flame protection material is an insulating layer acting to brake heat. The foaming mass prevents oxygen supply and therefore the spread of flames.

Optimal protection

Naturally the closures offer all the proven S.C.A.T. quality features to protect the user and the environment. The air valve blocks combustible solvent vapors and cleans dust and contaminant particles from the incoming air.

All limit values were fallen well below

During tests in the firing chamber, SafetyCaps attained the highest fire class V0 and were significantly below all UL-94 test criteria.

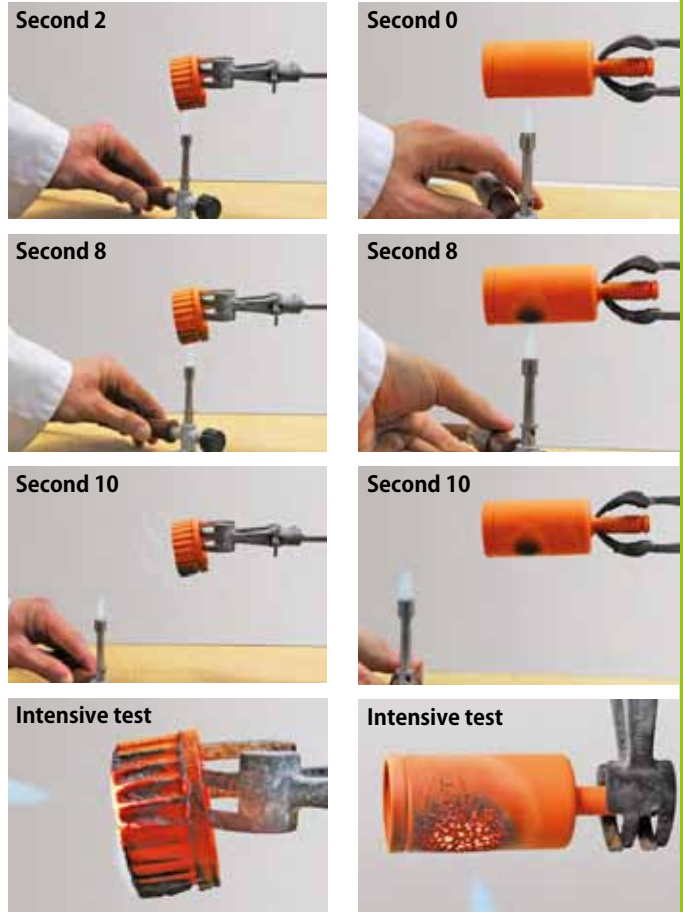

UL 94 test criteria	Nominal V0	Actual V0 SafetyCaps	Actual V0 Exhaust filter housing
Flame persistence time of the test sample after first exposure to flame	10	0	0
Flame persistence time of the test sample after second exposure to flame	30	1	1
Sum of all flame persistence times	50	2	3
Combustion of the cotton batting	No	No	No



Waste systems

SafetyWasteCaps – One system for every thread

The fluids in the waste containers in the laboratory are overwhelmingly poisonous – the user often does not know which mixture can emerge in the canisters. Closed safety systems from S.C.A.T. Europe offer reassuring protection and also guarantee efficient work in the laboratory.

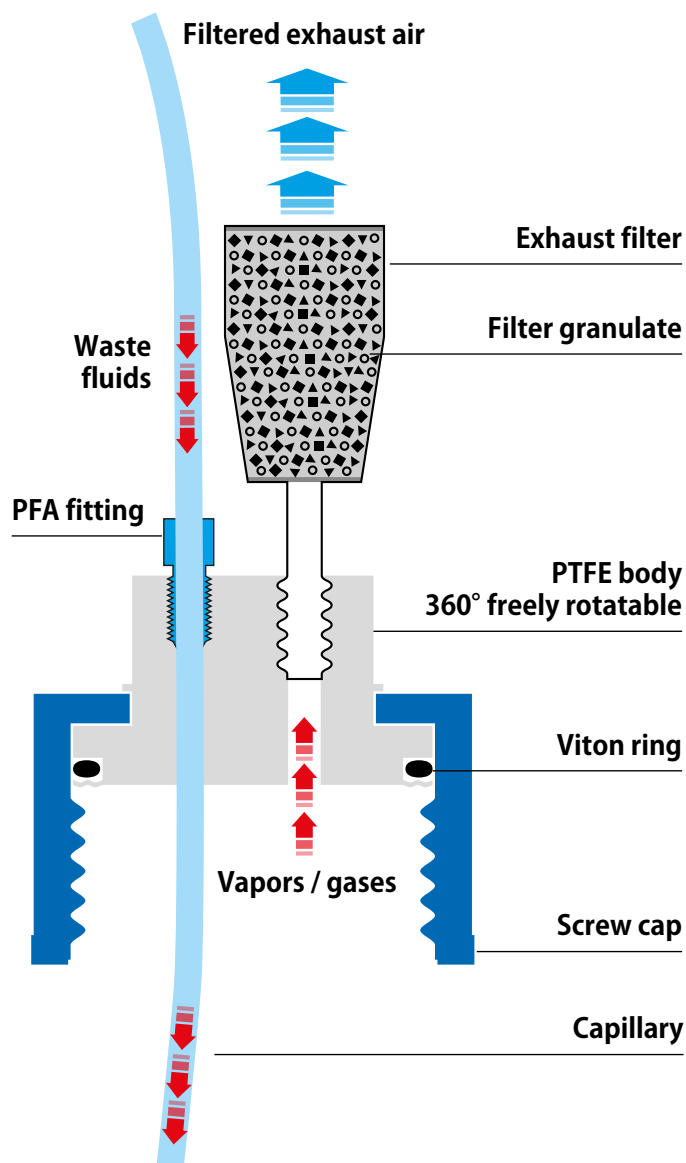

- » **Filter system against harmful vapors**
Exhaust filters in different sizes you will find on pages 59 - 60.
- » **Different thread sizes**
Use SafetyWasteCaps on your available containers, or order the appropriate canisters at the same time! Starting from Page 87.
- » **Resistant against aggressive media**
Because they are made of pure PTFE and PE-HD, SafetyWasteCaps are resistant against organic solvents, acids and lyes.



Incorrect disposal of laboratory waste is highly dangerous



Safe and clean disposal with S.C.A.T. SafetyWasteCaps



Waste systems

Central element of the waste system: Exhaust filter protects from harmful vapors

Exhaust filters keep your work-space safe clean. The exhaust filter is an essential component of the S.C.A.T. safety system. It cleans solvent vapors from the exhaust air.

With a specific surface of **1,200 m²/g**, our multicomponent granulate is the optimum filter media for nearly all solvent vapors. It is based on active charcoal and contains additional components which prevent sticking or clump formation and so prevents restriction of the filter performance. **99% of the volatile substances are captured here.**



Safety at the push of a button with the helpful change indicator

Exhaust filters are permanently exposed to vapours, dust particles and pollutants. Exchange saturated filters within their service life to maintain your workspace safety. With the useful **change indicator** the inspection is easier than ever before.

Install the exhaust filter as usual on your solvent reservoir. The filters fit to all S.C.A.T. waste systems. **By pushing the button the activation is done.**

The change indicator shows the elapsed service life clearly and is easy to observe.



Turn in the filter and activate at the push of a button.

The change indicator signals if an exchange become due.

Due to different container sizes and space conditions on smaller SafetyWasteCaps we offer exhaust filters in various sizes. We also offer exhaust filter size L (volume optimized, recommended for waste containers with a volume of more than 20 liters) and XL-versions for barrels. All exhaust filters you will find on the pages 59 - 60.



Part No. 610 534
Exhaust filter "S"
3 Months



Part No. 610 535
Exhaust filter "M"
6 Months

Waste systems

The capillary connector



- » Capillaries \varnothing 2.3/3.2 mm OD (\varnothing 1.6 mm optional)
- » Several systems can be connected to one waste container
- » Capillary fixation with PFA fittings
- » More possible connections through the use of adapters

Direct connection of your HPLC with the disposal system. The SafetyWasteCaps are delivered ready for connection and fit capillaries with an outer diameter of 2.3 and 3.2 mm. (Fittings for capillaries with 1.6 mm outer diameter optionally available). For larger filling quantities there are variants with tube connector.

Our caps are suitable with any HPLC system. If you like to connect capillaries even less than provided on your SafetyWasteCap you can block remaining connections with blind plugs.

Accessories for the capillary connector you will find on page 105.

The tube connector



- » Standard fitting for tubes with \varnothing 6.4 - 9.0 mm ID
- » Flexible like no other: numerous tube fittings available
- » Up to 8 possible connections through the use of adapters

Larger waste tubes fit the tube connector. The standard connector design is for flexible tubes with an inner diameter of 6.4–9.0 mm.

We also have suitable connections for other tube diameters! On **page 107** you will find all of our tube fittings which you can turn into the tube connector and on **page 108** all suitable adapters. The images are shown in the scale of 1:1 so you can determine your required size easily.

Accessories for the tube connector you will find on page 107. Selection of adapters on page 108.

Safety funnel with automatic closure



- » Maximum charge 280 ml (if valve is closed)
- » Available for SafetyWasteCaps with all common thread sizes
- » Safely collect sample residues and solvents
- » Valve closes automatically after filling

The useful funnel for filling smaller amounts of solvent, e.g. for preparing samples or emptying vials. When the button is released, the automatic mechanism closes and the canister never stands open in the laboratory. Harmful vapors can not escape without passing the exhaust filter.

For larger amounts we recommend our funnels with ball valve or hinged lid. An overview of the several types you will find on **page 63**.

Our range of safety funnels for larger filling quantities you will find starting from page 63.

Safety funnel with shut-off



- » Filling quantity 500 ml (if shut-off is closed)
- » Available for SafetyWasteCaps with all common thread sizes
- » Safe closing through shut-off
- » Both hands free for filling

For filling closed receptacles without inconvenient unscrewing of the canister. For safe disposal of medium amounts of typical laboratory fluids.

The funnel is opened and closed by turning the shut-off - this leaves both of your hands free to handle bottles and beakers, and then re-close the container quickly and cleanly.

Our range of safety funnels for larger filling quantities you will find starting from page 63.

Waste systems

Level control (mechanical)



- » Optical warning signal protects from overflowing
- » Ideal for containers of opaque material
- » Never vacate the laboratory again due to hazardous vapors

Overflowing waste containers in a laboratories can be dangerous when work is done with critical substances and solvents. Dangerous fumes can spread fast. This is not only dangerous for individual health but under certain circumstances, can also lead to an explosion.

The red floater is immediately visible if the container has reached the critical fill level. Even if there are many canisters, with a single glance you have everything under control. No overflow or interruption due to drained containers.

Further informations about level control starting from page 73.

Level control (electronic)



- » SafetyWasteCaps with electronic level control transmit warning signals to external connected electronic signal boxes
- » Monitoring of filling levels over greater distances from up to 200 m

Keep an eye on fill levels even from greater distances: Thanks to electronic level warning, you are informed in time when a waste container has filled up. Thanks to the extension cable, the signal box can be set up spatially separated from the container at variable distances.

SafetyWasteCaps with electronic level control can be connected to electronic signal boxes with 1-5 input lines. These offer automation and control of external devices such as pumps or valves.

All electronic signal boxes can be found starting from page 77.

Ground connection



- » Additive protection from explosive mixtures of waste in waste containers
- » For use with containers made from electrostatic conductive PE-HD

The contents of the waste containers can be additionally secured with the grounding connector. The grounding tube of electrostatic conductive plastic hangs into the liquid and makes contact.

On the top of the cap the contact can be conducted with a grounding cable.

Further grounding cables with mounted clamps and connectors you will find on page 115.



Fire-resistant material



- » Self-extinguishing material in case of fire
- » Combustion chamber tests with best value
- » Optimal protection - Naturally the closures offer all the proven S.C.A.T. quality features to protect the user and the environment.

In case of fire, the worldwide unique flame protection material is an insulating layer acting to brake heat. The foaming mass prevents oxygen supply and therefore the spread of flames. Naturally the closures offer all the proven S.C.A.T. quality features to protect the user and the environment. All limit values were fallen well below: During tests in the combustion chamber, SafetyCaps attained the highest fire class V0 and were significantly below all UL-94 test criteria.

**Fire-resistant SafetyWasteCaps on page 35.
Fire-resistant exhaust filters on page 59.**

Waste systems

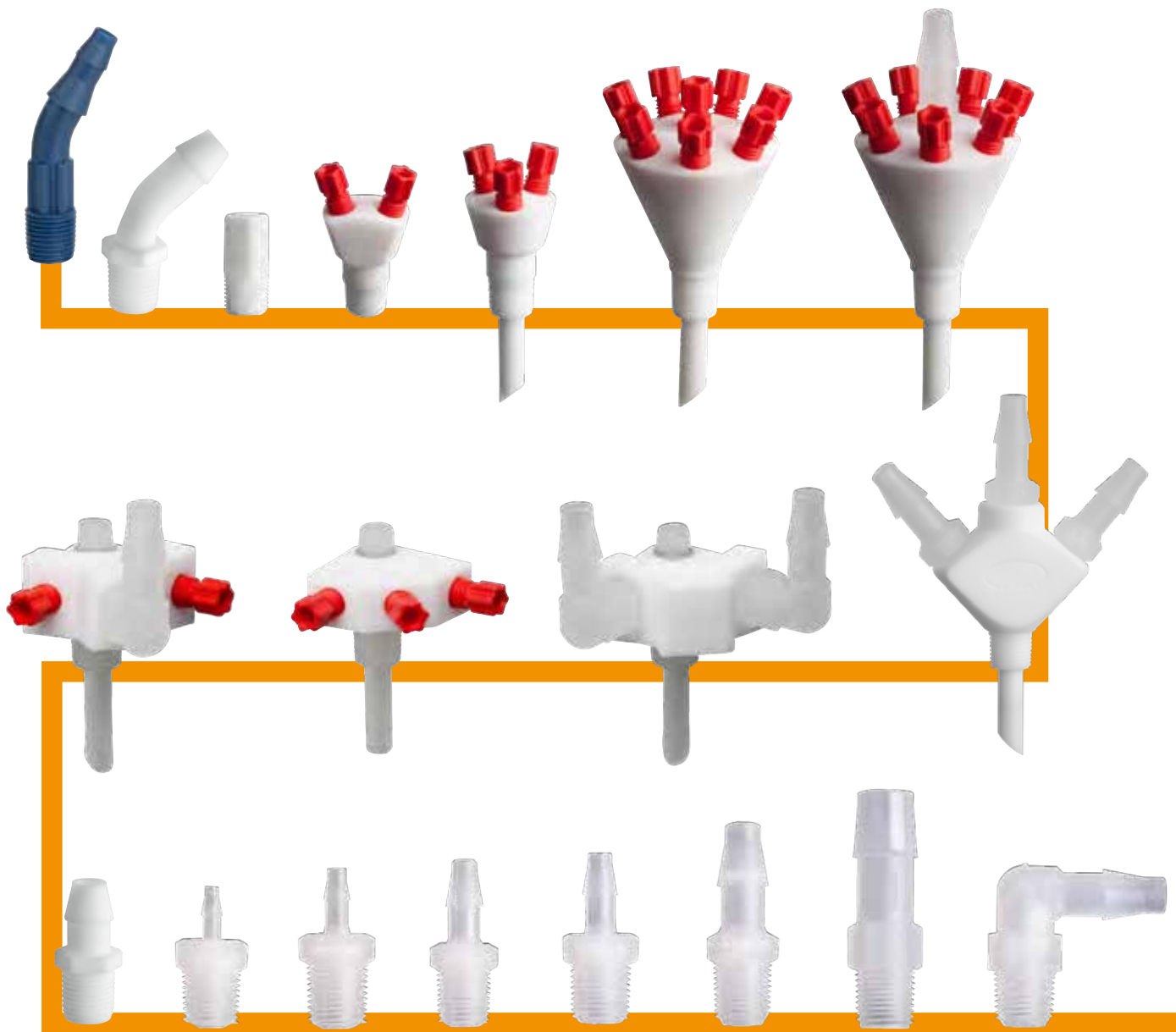

One system – endless possibilities!

A diversity which only S.C.A.T. Europe can provide. Through our years of experience and our commitment to provide solutions for the safe handling of hazardous waste liquids, we are familiar with all the connectors of laboratories in the world. Many of our products were developed from specific customer requirements and have become integral parts of our standard range.

A huge range of accessories starting from page 99.



Flexible like no other! The tube connector

The most special feature of our tube connector is its flexibility. The standard connector included in the scope of delivery can be exchanged with numerous adapters. This way, you can increase the number of connections or connect tubes with different diameters. You have many possibilities to connect several systems to one waste container.



All suitable adapters for the tube connector you will find on the pages 107 - 108 and on the useful fold out pages at the end of this chapter.



Tubes and capillaries you will find on page 117.

SafetyWasteCaps

Thread S 40 / GL 40

Thread GL 45

A 107 108



S 40 / GL 40

B 107 109





S 40 / GL 40

C 107 912





GL 45

D 107 923

GL 45

E 108 921

GL 45

F 112 921



GL 45

Helpful ordering tool

An overview, showing all possible connections to the tube connector at SafetyWasteCaps, you will find on the helpful fold out pages at the end of this chapter.

Offset adapter

Various offset adapters for exhaust filters you will find on page 104.



Thread information

GL 45 is the most frequent thread size for supply and waste containers in the laboratory. Many chemicals are delivered in GL 45 bottles.

ca. 44.5 mm = GL 45
ca. 40 mm = S 40 / GL 40

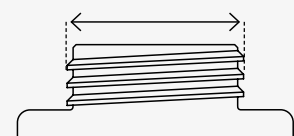

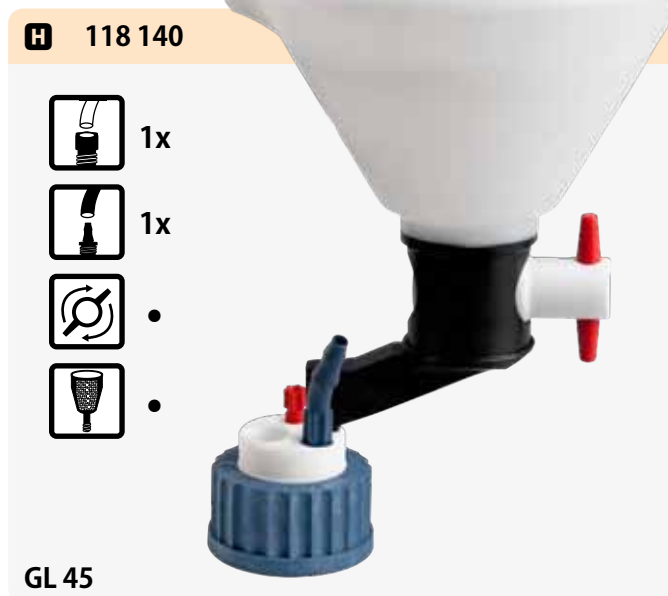
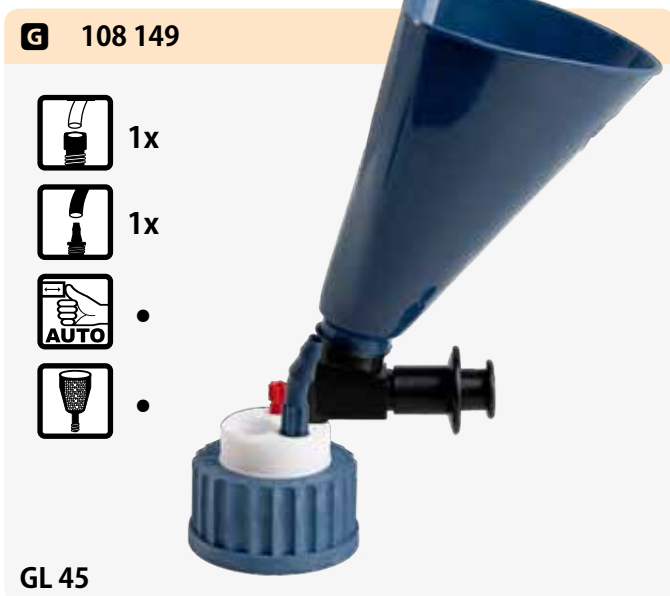

What kind of thread my canister has?

An overview, showing all helpful thread informations and measurements, you will find on the pages 87 - 88.

What is included in the scope of delivery?

The shown pictures accord to the scope of delivery. Fittings for capillaries with 2.3 / 3.2 mm outer diameter and if applicable, a tube fitting for tubes with 6.4 - 9.0 mm inner diameter are included.

Protect from harmful vapors!

Due to different container sizes and space conditions on smaller SafetyWasteCaps we offer exhaust filters in various sizes. Just choose your suitable size **S, M and L** for service lives from 3 up to 6 months. All exhaust filters you will find on the pages 59 - 60.

Fig.	Part No.	Thread	Capillary connector 2.3 / 3.2 mm OD	Tube connector 6.4 - 9.0 mm ID	Connector for exhaust filter	Safety funnel with automatic closure	Safety funnel with shut-off	Ground connection	Fire-resistant
A	107 108	S 40 / GL 40	3x	-	•	-	-	-	-
B	107 109	S 40 / GL 40	2x	1x	•	-	-	-	-
C	107 912	GL45	3x	-	•	-	-	-	-
-	112 912	GL45	3x	-	•	-	-	-	•
D	107 923	GL45	2x	1x	•	-	-	-	-
-	112 923	GL45	2x	1x	•	-	-	-	•
E	108 921	GL45	4x	1x	•	-	-	-	-
F	112 921	GL45	4x	1x	•	-	-	-	•
G	108 149	GL45	1x	1x	•	•	-	-	-
H	118 140	GL45	1x	1x	•	-	•	-	-

SafetyWasteCaps Thread S 50 (space-saving canister)



Helpful ordering tool

An overview, showing all possible connections to the tube connector at SafetyWasteCaps, you will find on the helpful fold out pages at the end of this chapter.

Offset adapter

Various offset adapters for exhaust filters you will find on page 104.

Base

The useful base for 2 space saving canisters and further informations you will find on page 91 - 92.



Space saving canister, only 65 mm wide!

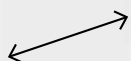

Thread information

Appropriate thread for our space-saving canisters.

ca. 50 mm





What kind of thread my canister has?

An overview, showing all helpful thread informations and measurements, you will find on the pages 87 - 88.

What is included in the scope of delivery?

The shown pictures accord to the scope of delivery. Fittings for capillaries with 2.3 / 3.2 mm outer diameter and if applicable, a tube fitting for tubes with 6.4 - 9.0 mm inner diameter are included.

Protect from harmful vapors!

Due to different container sizes and space conditions on smaller SafetyWasteCaps we offer exhaust filters in various sizes. Just choose your suitable size **S, M and L** for service lives from 3 up to 6 months. All exhaust filters you will find on the pages 59 - 60.

Fig.	Part No.	Capillary connector 2.3 / 3.2 mm OD	Tube connector 6.4 - 9.0 mm ID	Connector for exhaust filter	Level control (mechanical)	Level control (electronic)	Safety funnel with automatic closure	Safety funnel with shut-off	Ground connection
A	108 023	3x	-	•	-	-	-	-	-
B	108 024	3x	-	•	-	-	-	-	•
C	108 025	2x	1x	•	-	-	-	-	-
D	108 026	2x	1x	•	-	-	-	-	•
E	108 132	2x	-	•	-	-	•	-	-
F	118 141	2x	-	•	-	-	-	•	-

SafetyWasteCaps Thread S 51

A 107 930

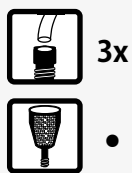

3x

•



B 107 922



2x

1x

•



C 107 942

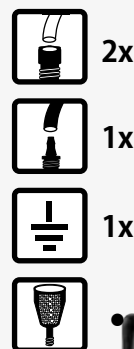

2x

1x

1x

•



Offset adapter

Various offset adapters for exhaust filters you will find on page 104.

Protect from harmful vapors!

Due to different container sizes and space conditions on smaller Safety-WasteCaps we offer exhaust filters in various sizes. Just choose your suitable size **S, M and L** for service lives from 3 up to 6 months. All exhaust filters you will find on the pages 59 - 60.

Thread information

Nearly identical to S 50. Only the outer diameter (OD) of the container thread is significantly different.

ca. 48 mm

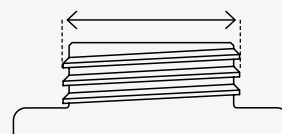



Helpful ordering tool

An overview, showing all possible connections to the tube connector at SafetyWasteCaps, you will find on the helpful fold out pages at the end of this chapter.

What kind of thread my canister has?

An overview, showing all helpful thread informations and measurements, you will find on the pages 87 - 88.

What is included in the scope of delivery?

The shown pictures accord to the scope of delivery. Fittings for capillaries with 2.3 / 3.2 mm outer diameter and if applicable, a tube fitting for tubes with 6.4 - 9.0 mm inner diameter are included.

Fig.	Part No.	Capillary connector 2.3 / 3.2 mm OD	Tube connector 6.4 - 9.0 mm ID	Connector for exhaust filter	Level control (mechanical) MAX	Level control (electronic) MAX	Safety funnel with automatic closure AUTO	Safety funnel with shut-off	Ground connection
A	107 930	3x	-	•	-	-	-	-	-
-	107 935	3x	-	•	-	-	-	-	•
B	107 922	2x	1x	•	-	-	-	-	-
C	107 942	2x	1x	•	-	-	-	-	•
-	107 241	2x	-	•	•	-	-	-	-
D	107 242	2x	-	•	-	•	-	-	-
E	107 243	1x	1x	•	-	-	•	-	-
F	107 244	1x	1x	•	-	-	-	•	-

SafetyWasteCaps Thread B 53

Helpful ordering tool

An overview, showing all possible connections to the tube connector at SafetyWasteCaps, you will find on the helpful fold out pages at the end of this chapter.

WASTE SYSTEMS

A 107 037

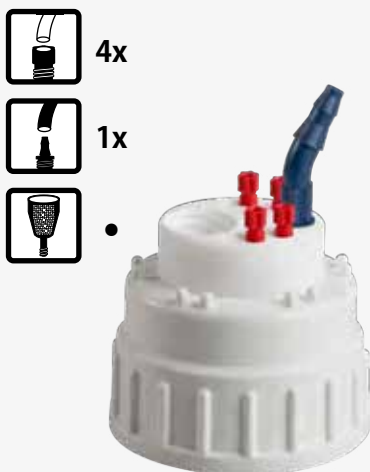

B 107 054



C 107 245



D 107 246



Thread information

For containers of the brand NALGENE®.

ca. 53 mm

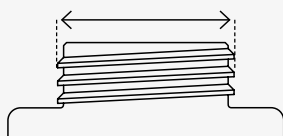

What kind of thread my canister has?

An overview, showing all helpful thread informations and measurements, you will find on the pages 87 - 88.











What is included in the scope of delivery?

The shown pictures accord to the scope of delivery. Fittings for capillaries with 2.3 / 3.2 mm outer diameter and if applicable, a tube fitting for tubes with 6.4 - 9.0 mm inner diameter are included.

Protect from harmful vapors!

Due to different container sizes and space conditions on smaller SafetyWasteCaps we offer exhaust filters in various sizes. Just choose your suitable size **S, M and L** for service lives from 3 up to 6 months. All exhaust filters you will find on the pages 59 - 60.

Fig.	Part No.	 Capillary connector 2.3 / 3.2 mm OD	 Tube connector 6.4 - 9.0 mm ID	 Connector for exhaust filter	 Level control (mechanical)	 Level control (electronic)	 Safety funnel with automatic closure	 Safety funnel with shut-off	 Ground connection
A	107 037	4x	1x	•	-	-	-	-	-
B	107 054	3x	1x	•	-	-	-	-	•
C	107 245	1x	1x	•	•	-	-	-	-
D	107 246	1x	1x	•	-	•	-	-	-
E	107 057	1x	1x	•	-	-	•	-	-
F	118 142	1x	1x	•	-	-	-	•	-

SafetyWasteCaps Thread S 55

A 107 917

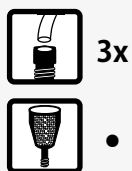

B 107 924



C 107 936

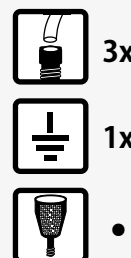

D 107 960



E 108 200

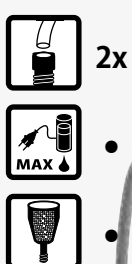

Helpful ordering tool

An overview, showing all possible connections to the tube connector at SafetyWasteCaps, you will find on the helpful fold out pages at the end of this chapter.

Thread information

The number "51" is often in the cover.

ca. 53.5 mm

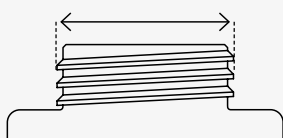

What kind of thread my canister has?

An overview, showing all helpful thread informations and measurements, you will find on the pages 87 - 88.













What is included in the scope of delivery?

The shown pictures accord to the scope of delivery. Fittings for capillaries with 2.3 / 3.2 mm outer diameter and if applicable, a tube fitting for tubes with 6.4 - 9.0 mm inner diameter are included.

Protect from harmful vapors!

Due to different container sizes and space conditions on smaller SafetyWasteCaps we offer exhaust filters in various sizes. Just choose your suitable size **S, M and L for service lives from 3 up to 6 months. All exhaust filters you will find on the pages 59 - 60.**

Fig.	Part No.	 Capillary connector 2.3 / 3.2 mm OD	 Tube connector 6.4 - 9.0 mm ID	 Connector for exhaust filter	 Level control (mechanical)	 Level control (electronic)	 Safety funnel with automatic closure	 Safety funnel with shut-off	 Ground connection
A	107 917	3x	-	●	-	-	-	-	-
B	107 924	2x	1x	●	-	-	-	-	-
C	107 936	3x	-	●	-	-	-	-	●
-	107 943	2x	1x	●	-	-	-	-	●
D	107 960	3x	-	●	●	-	-	-	-
-	107 963	2x	1x	●	●	-	-	-	-
-	108 030	3x	-	●	●	-	-	-	●
E	108 200	3x	-	●	-	●	-	-	-
-	108 201	2x	1x	●	-	●	-	-	-
F	108 033	2x	-	●	-	-	●	-	-
-	108 128	-	-	●	-	-	●	-	-
G	118 143	2x	-	●	-	-	-	●	-
-	118 149	-	-	●	-	-	-	●	-

SafetyWasteCaps Thread S 60/61

A 107 918

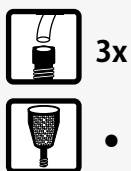

B 107 925



C 107 916

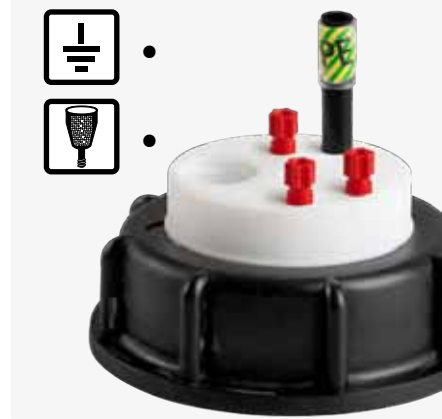

D 107 964

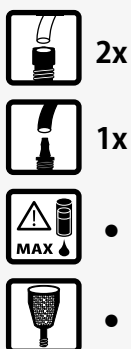

E 108 403

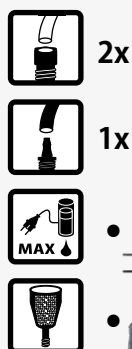

F 108 034



Thread information

The number "61" is often in the cover.

ca. 59 mm

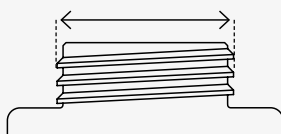

Helpful ordering tool

An overview, showing all possible connections to the tube connector at SafetyWasteCaps, you will find on the helpful fold out pages at the end of this chapter.

Protect from harmful vapors! All exhaust filters you will find on the pages 59 - 60.

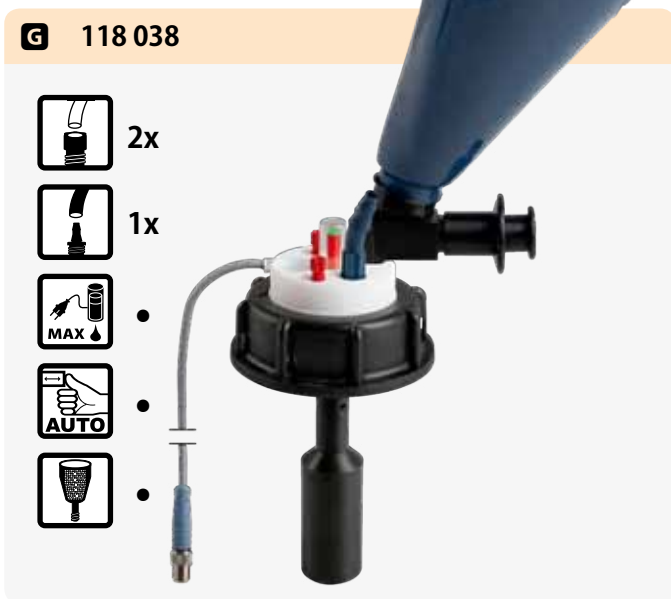

What is included in the scope of delivery?

The shown pictures accord to the scope of delivery. Fittings for capillaries with 2.3 / 3.2 mm outer diameter and if applicable, a tube fitting for tubes with 6.4 - 9.0 mm inner diameter are included.

Fig.	Part No.	Capillary connector 2.3 / 3.2 mm OD	Tube connector 6.4 - 9.0 mm ID	Connector for exhaust filter	Level control (mechanical)	Level control (electronic)	Safety funnel with automatic closure	Safety funnel with shut-off	Ground connection
A	107 918	3x	-	•	-	-	-	-	-
B	107 925	2x	1x	•	-	-	-	-	-
C	107 916	3x	-	•	-	-	-	-	•
-	107 944	2x	1x	•	-	-	-	-	•
D	107 964	2x	1x	•	•	-	-	-	-
-	108 964	2x	1x	•	•	-	-	-	•
-	107 961	3x	-	•	•	-	-	-	-
-	108 961	3x	-	•	•	-	-	-	•
E	108 403	2x	1x	•	-	•	-	-	-
-	108 404	2x	1x	•	-	•	-	-	•
-	108 401	3x	-	•	-	•	-	-	-
-	108 402	3x	-	•	-	•	-	-	•
F	108 034	2x	-	•	-	-	•	-	-
-	108 134	2x	-	•	•	-	•	-	-
-	108 138	2x	1x	•	•	-	•	-	-
-	118 034	2x	-	•	-	•	•	-	-
G	118 038	2x	1x	•	-	•	•	-	-
-	108 129	-	-	•	-	-	•	-	-
H	118 144	2x	-	•	-	-	-	•	-
-	118 244	2x	-	•	•	-	-	•	-
-	118 242	2x	1x	•	•	-	-	•	-
-	118 150	-	-	•	-	-	-	•	-

SafetyWasteCaps Thread B 63

A 107 051

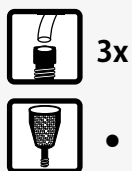

B 107 050



C 107 038



D 107 247



E 107 248

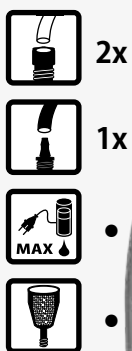

F 107 249



Helpful ordering tool

An overview, showing all possible connections to the tube connector at SafetyWasteCaps, you will find on the helpful fold out pages at the end of this chapter.

Thread information

For containers of the brand NALGENE®.

ca. 62 mm

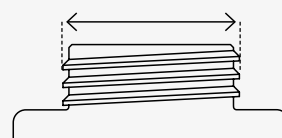

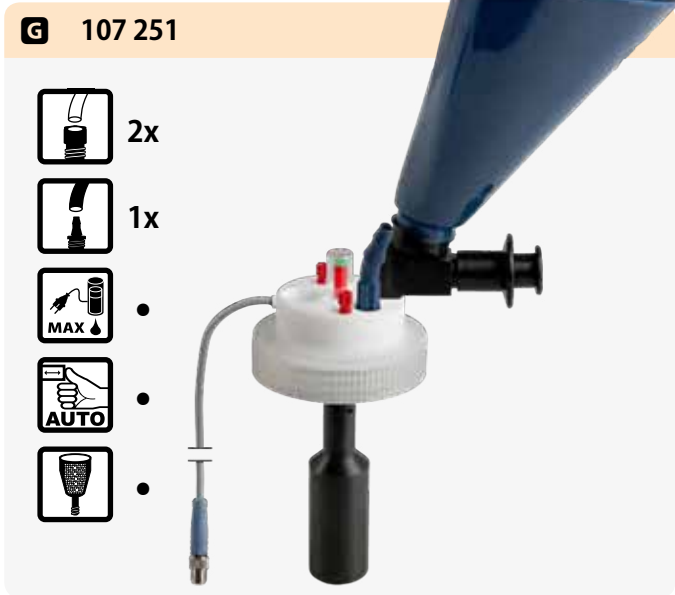

What is included in the scope of delivery?

The shown pictures accord to the scope of delivery. Fittings for capillaries with 2.3 / 3.2 mm outer diameter and if applicable, a tube fitting for tubes with 6.4 - 9.0 mm inner diameter are included.

What kind of thread my canister has?

An overview, showing all helpful thread informations and measurements, you will find on the pages 87 - 88.

Protect from harmful vapors!

Due to different container sizes and space conditions on smaller SafetyWasteCaps we offer exhaust filters in various sizes. Just choose your suitable size **S, M and L** for service lifes from 3 up to 6 months. All exhaust filters you will find on the pages 59 - 60.

Fig.	Part No.	Capillary connector 2.3 / 3.2 mm OD	Tube connector 6.4 - 9.0 mm ID	Connector for exhaust filter	Level control (mechanical)	Level control (electronic)	Safety funnel with automatic closure	Safety funnel with shut-off	Ground connection
A	107 051	3x	-	•	-	-	-	-	-
B	107 050	2x	1x	•	-	-	-	-	-
C	107 038	1x	3x	•	-	-	-	-	-
D	107 247	2x	1x	•	•	-	-	-	-
E	107 248	2x	1x	•	-	•	-	-	-
F	107 249	2x	1x	•	-	-	•	-	-
-	107 250	2x	1x	•	•	-	•	-	-
G	107 251	2x	1x	•	-	•	•	-	-
H	107 252	2x	1x	•	-	-	-	•	-
-	107 253	2x	1x	•	•	-	-	•	-
-	107 254	2x	1x	•	-	•	-	•	-

SafetyWasteCaps Thread S 65

A 108 046

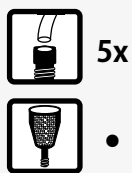

B 108 047

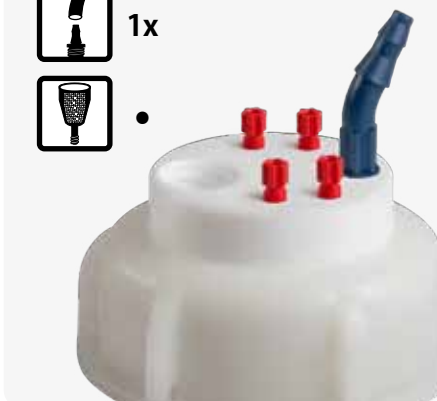

C 108 054



D 107 969



E 108 203

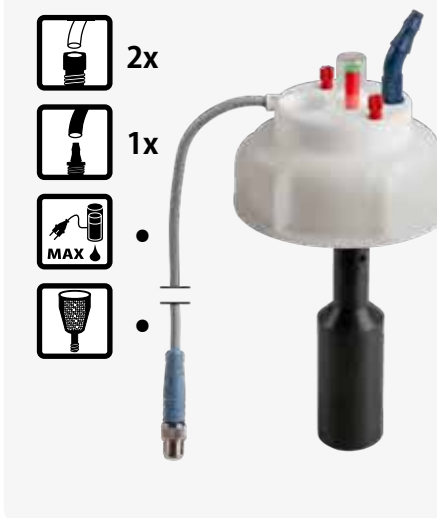
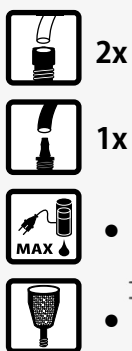

F 108 150



Helpful ordering tool

An overview, showing all possible connections to the tube connector at SafetyWasteCaps, you will find on the helpful fold out pages at the end of this chapter.

What kind of thread my canister has?

An overview, showing all helpful thread informations and measurements, you will find on the pages 87 - 88.

Thread information

For containers of the brand KAUTEX®.

ca. 64.5 mm

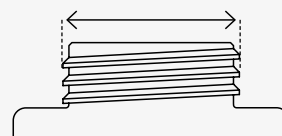

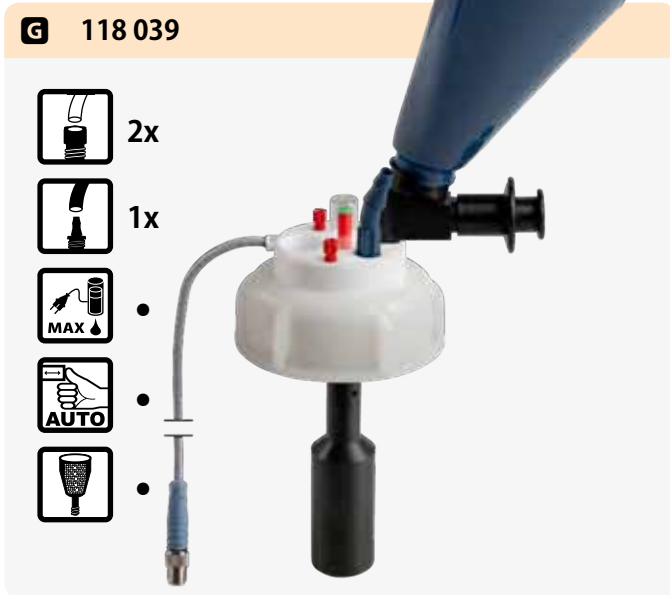

What is included in the scope of delivery?

The shown pictures accord to the scope of delivery. Fittings for capillaries with 2.3 / 3.2 mm outer diameter and if applicable, a tube fitting for tubes with 6.4 - 9.0 mm inner diameter are included.

Protect from harmful vapors!

Due to different container sizes and space conditions on smaller SafetyWasteCaps we offer exhaust filters in various sizes. Just choose your suitable size **S, M and L** for service lives from 3 up to 6 months. All exhaust filters you will find on the pages 59 - 60.

Fig.	Part No.	Capillary connector 2.3 / 3.2 mm OD	Tube connector 6.4 - 9.0 mm ID	Connector for exhaust filter	Level control (mechanical)	Level control (electronic)	Safety funnel with automatic closure	Safety funnel with shut-off	Ground connection
A	108 046	5x	-	•	-	-	-	-	-
B	108 047	4x	1x	•	-	-	-	-	-
C	108 054	5x	-	•	-	-	-	-	•
-	108 055	4x	1x	•	-	-	-	-	•
-	107 968	4x	-	•	•	-	-	-	-
D	107 969	4x	1x	•	•	-	-	-	-
-	108 202	3x	-	•	-	•	-	-	-
E	108 203	2x	1x	•	-	•	-	-	-
F	108 150	4x	-	•	-	-	•	-	-
-	108 133	3x	1x	•	•	-	•	-	-
-	108 135	4x	-	•	•	-	•	-	-
-	118 035	4x	-	•	-	•	•	-	-
G	118 039	3x	1x	•	-	•	•	-	-
H	118 145	4x	-	•	-	-	-	•	-
-	118 245	4x	-	•	•	-	-	•	-
-	118 246	3x	1x	•	•	-	-	•	-

SafetyWasteCaps Thread S 70/71

A 107 913

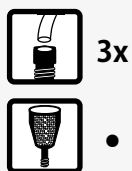

B 107 926



C 107 915



D 107 965

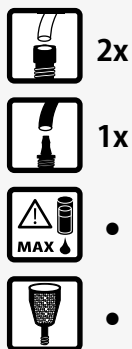

E 108 407

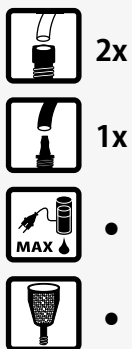

F 108 035



Helpful ordering tool

An overview, showing all possible connections to the tube connector at SafetyWasteCaps, you will find on the helpful fold out pages at the end of this chapter.

Gewindeinfo

The number "71" is often in the cover.

ca. 70 mm

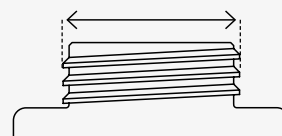



What is included in the scope of delivery?

The shown pictures accord to the scope of delivery. Fittings for capillaries with 2.3 / 3.2 mm outer diameter and if applicable, a tube fitting for tubes with 6.4 - 9.0 mm inner diameter are included.

Protect from harmful vapors! All exhaust filters you will find on the pages 59 - 60.

Fig.	Part No.	Capillary connector 2.3 / 3.2 mm OD	Tube connector 6.4 - 9.0 mm ID	Connector for exhaust filter	Level control (mechanical) MAX	Level control (electronic) MAX	Safety funnel with automatic closure AUTO	Safety funnel with shut-off	Ground connection
A	107 913	3x	-	●	-	-	-	-	-
B	107 926	2x	1x	●	-	-	-	-	-
C	107 915	3x	-	●	-	-	-	-	●
-	107 945	2x	1x	●	-	-	-	-	●
-	107 962	3x	-	●	●	-	-	-	-
D	107 965	2x	1x	●	●	-	-	-	-
-	108 405	3x	-	●	-	●	-	-	-
-	108 406	3x	-	●	-	●	-	-	●
E	108 407	2x	1x	●	-	●	-	-	-
-	108 408	2x	1x	●	-	●	-	-	●
F	108 035	4x	-	●	-	-	●	-	-
-	108 136	4x	-	●	●	-	●	-	-
-	108 139	3x	1x	●	●	-	●	-	-
-	118 036	4x	-	●	-	●	●	-	-
G	118 040	4x	1x	●	-	●	●	-	-
H	118 146	4x	-	●	-	-	-	●	-
-	118 247	4x	-	●	●	-	-	●	-
-	118 248	4x	1x	●	●	-	-	●	-

SafetyWasteCaps Thread B 83

A 107 036

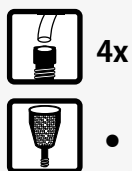

B 107 052



C 107 034



D 108 156



E 108 205



F 108 151



Thread information

For containers of the brand NALGENE®

ca. 88 mm

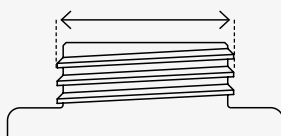

Helpful ordering tool

An overview, showing all possible connections to the tube connector at SafetyWasteCaps, you will find on the helpful fold out pages at the end of this chapter.



What kind of thread my canister has?









An overview, showing all helpful thread informations and measurements, you will find on the pages 87 - 88.

What is included in the scope of delivery?

The shown pictures accord to the scope of delivery. Fittings for capillaries with 2.3 / 3.2 mm outer diameter and if applicable, a tube fitting for tubes with 6.4 - 9.0 mm inner diameter are included.

Protect from harmful vapors!

Due to different container sizes and space conditions on smaller SafetyWasteCaps we offer exhaust filters in various sizes. Just choose your suitable size **S, M and L** for service lifes from 3 up to 6 months. All exhaust filters you will find on the pages 59 - 60.

Fig.	Part No.	 Capillary connector 2.3 / 3.2 mm OD	 Tube connector 6.4 - 9.0 mm ID	 Connector for exhaust filter	 Level control (mechanical)	 Level control (electronic)	 Safety funnel with automatic closure	 Safety funnel with shut-off	 Ground connection
A	107 036	4x	-	•	-	-	-	-	-
B	107 052	4x	-	•	-	-	-	-	•
C	107 034	4x	1x	•	-	-	-	-	-
-	107 053	4x	1x	•	-	-	-	-	•
-	108 155	4x	-	•	•	-	-	-	-
D	108 156	4x	1x	•	•	-	-	-	-
E	108 205	4x	1x	•	-	•	-	-	-
-	108 204	4x	-	•	-	•	-	-	-
F	108 151	4x	-	•	-	-	•	-	-
G	107 255	4x	1x	•	-	•	•	-	-
H	118 147	4x	-	•	-	-	-	•	-

SafetyWasteCaps Thread S 90

A 107 927

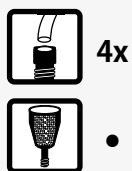

B 107 928



C 107 947



D 107 967

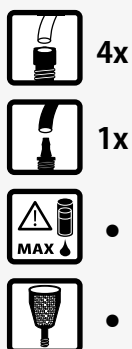

E 108 231



F 108 152



Helpful ordering tool

An overview, showing all possible connections to the tube connector at SafetyWasteCaps, you will find on the helpful fold out pages at the end of this chapter.

Thread information

The number "D90" is often in the cover.

ca. 88 mm

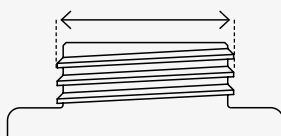

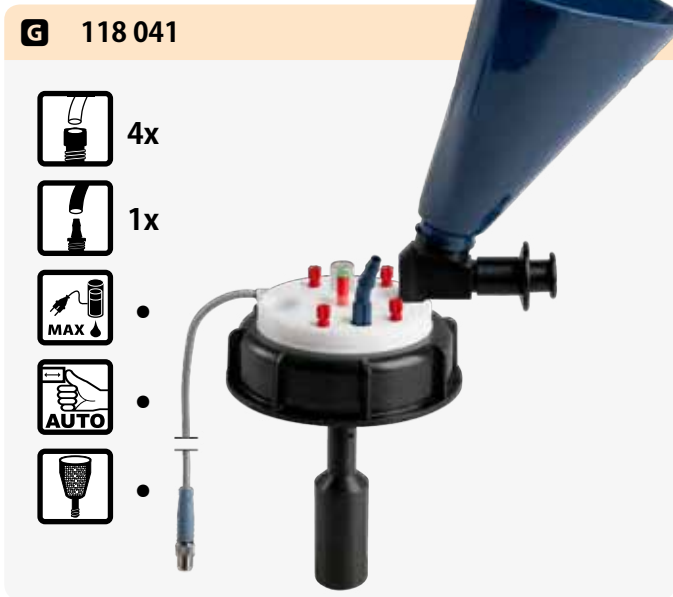

What is included in the scope of delivery?

The shown pictures accord to the scope of delivery. Fittings for capillaries with 2.3 / 3.2 mm outer diameter and if applicable, a tube fitting for tubes with 6.4 - 9.0 mm inner diameter are included.

Protect from harmful vapors! All exhaust filters you will find on the pages 59 - 60.

Fig.	Part No.	Capillary connector 2.3 / 3.2 mm OD	Tube connector 6.4 - 9.0 mm ID	Connector for exhaust filter	Level control (mechanical)	Level control (electronic)	Safety funnel with automatic closure	Safety funnel with shut-off	Ground connection
A	107 927	4x	-	●	-	-	-	-	-
B	107 928	4x	-	●	-	-	-	-	●
C	107 947	4x	1x	●	-	-	-	-	-
-	107 949	4x	1x	●	-	-	-	-	●
-	107 966	4x	-	●	●	-	-	-	-
D	107 967	4x	1x	●	●	-	-	-	-
-	108 031	4x	-	●	●	-	-	-	●
-	108 230	4x	-	●	-	●	-	-	-
E	108 231	4x	1x	●	-	●	-	-	-
F	108 152	4x	-	●	-	-	●	-	-
-	108 137	4x	-	●	●	-	●	-	-
-	108 140	4x	1x	●	●	-	●	-	-
-	118 037	4x	-	●	-	●	●	-	-
G	118 041	4x	1x	●	-	●	●	-	-
H	118 148	4x	-	●	-	-	-	●	-
-	118 249	4x	-	●	●	-	-	●	-
-	118 250	4x	1x	●	●	-	-	●	-

SafetyWasteCaps Thread S 95

A 107 256

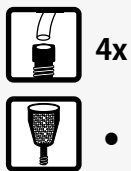

B 107 257



C 107 258



D 107 259

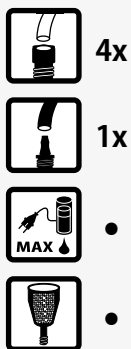

E 107 260



Thread information

Largest thread from our standard assortment. For additional sizes, we also offer customized products according to customer specifications.

ca. 94 mm

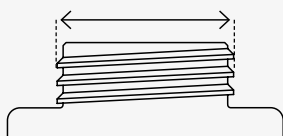

Helpful ordering tool

An overview, showing all possible connections to the tube connector at SafetyWasteCaps, you will find on the helpful fold out pages at the end of this chapter.





What kind of thread my canister has?









An overview, showing all helpful thread informations and measurements, you will find on the pages 87 - 88.

What is included in the scope of delivery?

The shown pictures accord to the scope of delivery. Fittings for capillaries with 2.3 / 3.2 mm outer diameter and if applicable, a tube fitting for tubes with 6.4 - 9.0 mm inner diameter are included.

Protect from harmful vapors!

Due to different container sizes and space conditions on smaller SafetyWasteCaps we offer exhaust filters in various sizes. Just choose your suitable size **S, M and L** for service lives from 3 up to 6 months. All exhaust filters you will find on the pages 59 - 60.

Fig.	Part No.	 Capillary connector 2.3 / 3.2 mm OD	 Tube connector 6.4 - 9.0 mm ID	 Connector for exhaust filter	 Level control (mechanical)	 Level control (electronic)	 Safety funnel with automatic closure	 Safety funnel with shut-off	 Ground connection
A	107 256	4x	-	●	-	-	-	-	-
B	107 257	4x	1x	●	-	-	-	-	-
C	107 258	4x	1x	●	●	-	-	-	-
D	107 259	4x	1x	●	-	●	-	-	-
E	107 260	4x	1x	●	-	-	●	-	-
-	107 261	4x	1x	●	●	-	●	-	-
F	107 262	4x	1x	●	-	●	●	-	-
G	107 263	4x	1x	●	-	-	-	●	-
-	107 264	4x	1x	●	●	-	-	●	-
-	107 265	4x	1x	●	-	●	-	●	-

SafetyWasteCaps

Exhaust filters

WASTE SYSTEMS



The exhaust filter - central element of the S.C.A.T. waste system

All informations and explanations regarding the exhaust filter are shown on pages 27 - 28.

Offset adapter

Space problems on your SafetyWasteCap? No problem, offset adapters for the connection of exhaust filters you will find on page 104.



Fig.	Part No.	Filter size	Recommended for waste containers with a volume of...	Features	Service life
A	610 534	S (small)	up to 5 liters	Splash protection with change indicator	3 Months
B	112 911	S (small)	up to 5 liters	Fire-resistant	3 Months
C	610 535	M (medium)	up to 20 liters	Splash protection with change indicator	6 Months
D	112 914	M (medium)	up to 20 liters	Fire-resistant	6 Months
E	107 986	L (large)	more than 20 liters	Splash protection with change indicator	6 Months

Safety on stock!

The economy packages guarantee not only price advantages; you are always well-prepared for the upcoming filter change.



A 190 335



4 x 3 Months



S

B 190 336



3 x 6 Months



M

Fig.	Part No.	Description	Filter sizes	Number/unit
A	190 335	Economy package, exhaust filters with change indicator	S (small)	4 each
B	190 336	Economy package, exhaust filters with change indicator	M (medium)	3 each

C 108 985



9 Months



XL

D 108 986



12 Months



XXL

Exhaust filters for barrels



Fig.	Part No.	Filter size	Fill amount	Thread size	Recommended for barrel size	Service life	Unit
C	108 985	XL	520 g	G 3/4"	60 - 100 liters	9 Months	1
D	108 986	XXL	990 g	2" Mauser (BCS 70x6)	from 100 liters	12 Months	1
-	108 987	XXL	990 g	Double thread R 2" BSP/ G2" + 2" Tri-Sure	from 100 liters	12 Months	1



SafetyWasteCaps

Complete sets



- » Only one article number for the comprehensive safety system
- » No time consuming compilation of a configuration
- » Price advantage compared to ordering piece by piece

The useful base for 2 space saving canisters you will find on page 92.

Fig.	Part No. SET	 Capillary connector 2.3 / 3.2 mm OD	 Tube connector 6.4 - 9 mm ID	Scope of delivery	Dimensions W x H x D (mm)
A	107 307	2x	1x	107 951 Canister 5 liter, PP, thread GL 45 107 923 SafetyWasteCap, thread GL 45 610 534 Exhaust filter, size S	150 x 365 x 195
-	107 310	2x	1x	107 952 Canister 10 liter, PP, thread GL 45 107 923 SafetyWasteCap, thread GL 45 610 534 Exhaust filter, size S	190 x 415 x 230
B	107 328	2x	1x	107 998 Space saving canister, 5 liter, PP, thread S 50 108 025 SafetyWasteCap, thread S 50 610 534 Exhaust filter, size S	65 x 455 x 330



Flexible like no other! The tube connector

The most special feature of our tube connector is its flexibility. The standard connector included in the scope of delivery can be exchanged with numerous adapters. This way, you can increase the number of connections or connect tubes with different diameters. You have many possibilities to connect several systems to one waste container.

Useful overview,
please fold out the pages.

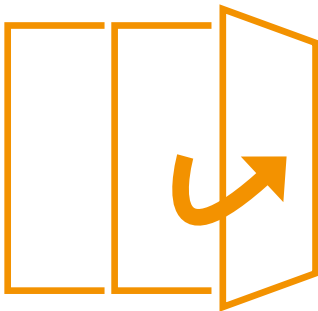



Flexible like no other! The tube connector

The most special feature of our tube connector is its flexibility. The standard connector included in the scope of delivery can be exchanged with numerous adapters. This way, you can increase the number of connections or connect tubes with different diameters. You have many possibilities to connect several systems to one waste container.

Useful overview,
please fold out the pages.

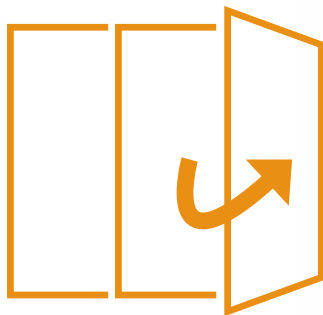

Accessories Accessories for the tube connector



Useful overview,
please fold out the pages.

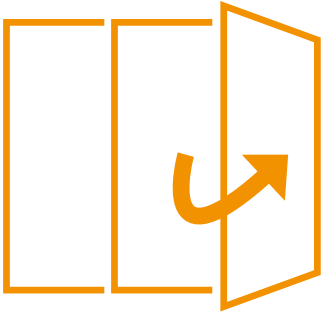



Accessories

Tube fittings for the tube connector



Images A - K shown on a scale of 1:1

Just add the tube and identify the size easily.



Fig.	Part No.	Description	For tube diameter	Material	Unit
A	117 808	Stepped fitting, curved	6.4 - 9 mm ID	PP	1
B	160 143	Tube fitting, curved	6.4 - 8 mm ID	PTFE	1
C	160 142	Tube fitting, straight	6.4 - 8 mm ID	PTFE	1
D	107 811	Tube fitting, straight	2 - 3 mm ID	PP	1
E	107 812	Tube fitting, straight	3 - 4 mm ID	PP	1
F	107 813	Tube fitting, straight	4 - 6 mm ID	PP	1
G	107 814	Tube fitting, straight	5 - 7 mm ID	PP	1
H	107 816	Tube fitting, straight	6.2 - 7.5 mm ID	PP	1
I	107 817	Tube fitting, straight	9.5 - 11 mm ID	PP	1
J	107 808	Tube fitting, angled	6.4 - 8 mm ID	PP	1
K	107 810	Tube fitting, angled	9.5 - 10 mm ID	PP	1

Accessories

Adapters for the tube connector



**Flexible like no other -
The tube connector**

Our adapters offer numerous connections.

L 160 141



M 160 132



N 160 137



O 160 129



P 160 131



Q 160 130



R 160 128



S 117 819



T 117 821



Fig.	Part No.	Description	For tube diameter		Material	Unit
-	160 506	Blind plug for tube connector	-		PTFE	1
L	160 141	2-in-1 collector	2.3 / 3.2 mm OD		PTFE / PFA	1
-	160 144	2-in-1 collector	2.3 / 3.2 mm OD		PTFE	1
M	160 132	3-in-1 collector	2.3 / 3.2 mm OD		PTFE / PFA	1
N	160 137	8-in-1 collector	2.3 mm OD		PTFE / PFA	1
O	160 129	8-in-1 collector	2.3 mm OD (7x)	6.4 mm ID (1x)	PTFE / PFA / PP	1
P	160 131	3-in-1 collector, angled	2.3 / 3.2 mm OD		PTFE / PFA / PP	1
Q	160 130	3-in-1 collector, angled	2.3 / 3.2 mm OD (2x)	6.4 mm ID (1x)	PTFE / PFA / PP	1
R	160 128	3-in-1 Sammler, straight	6.4 mm ID (3x)		PTFE / PP	1
S	117 819	Tube fitting, straight, + sealing nut	8 mm ID		PTFE	1
T	117 821	Tube fitting, straight, + sealing nut	6.5 mm ID		PTFE	1

Safety funnels

Optimal protection when collection liquid wastes

What does disposal of waste fluids look like?

Even laboratories often have archaic conditions for this. Open canisters and funnels, often without collecting tray – in the rarest cases, positioned under the exhaust – this is what the tragic reality looks like. But now there are closure systems corresponding to nearly all current waste containers, so retrofitting is easy to carry out without sacrificing flexibility.

Conclusion

Those who want to get their waste disposal under control and to create ideal conditions need a coherent concept. And S.C.A.T. Europe can provide this. More protection for humans and the environment: Our safety funnels are a one-time investment for many years of health and safety.

Together with our users, we have further optimized the S.C.A.T. safety funnels. The new design is optimized for areas with low ceilings. The PE-HD funnels are suitable for all types of chemicals. The funnels in black are electrostatic conductive as well and are delivered with a ground cable and clamp.

Funnels with integrated ball valve make sure that the containers remain securely closed after filling. The screw cap rotates freely, making it easier to unscrew the funnel.

A video says more than a thousand words

Many labs suffer from messy conditions when it comes to solvent and waste handling. The S.C.A.T. Europe team unveils the mistakes of the past and shows how to do it right.



**Just scan QR Code
and watch the Video.**



- » Made of high quality PE-HD
- » Removable sieve
- » Various thread sizes
- » Adapters for barrels available
- » Low design – also fits beneath low work surfaces
- » Available as electrostatic conductive
- » New design
- » Improved handling
- » Optimized application possibilities
- » World-wide unique

or directly visit: scat-europe.com/video

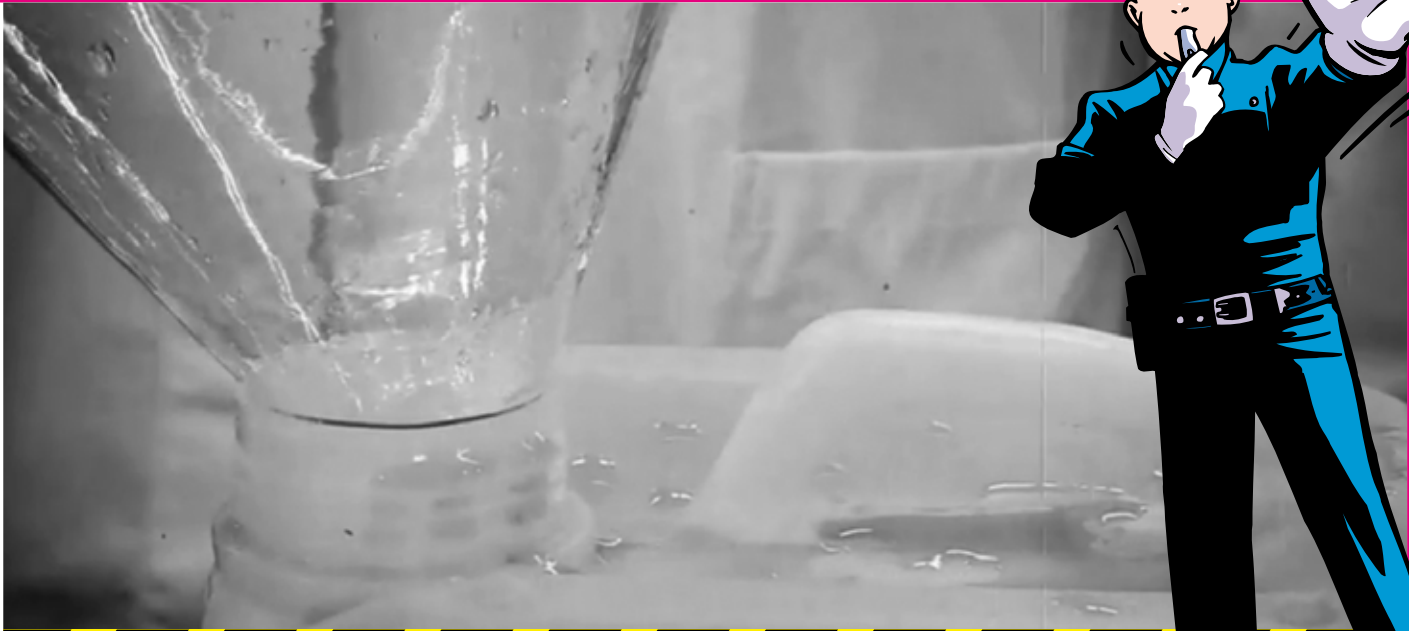

Incorrect disposal of laboratory waste is highly dangerous



Safe and clean disposal with S.C.A.T. safety funnels



Safety funnels

Safety funnels with ball valve

- » The ball floats and automatically closes after filling
- » Quick and safe disposal - with both hands free
- » Splash protection and sieve to catch dirt and larger contaminant particles

S.C.A.T. Europe safety funnels with ball valve and splash protection are world-wide unique and have become an efficient standard at the safe disposal of waste in laboratory and production. (Funnels with ball valve you will find on page 67).

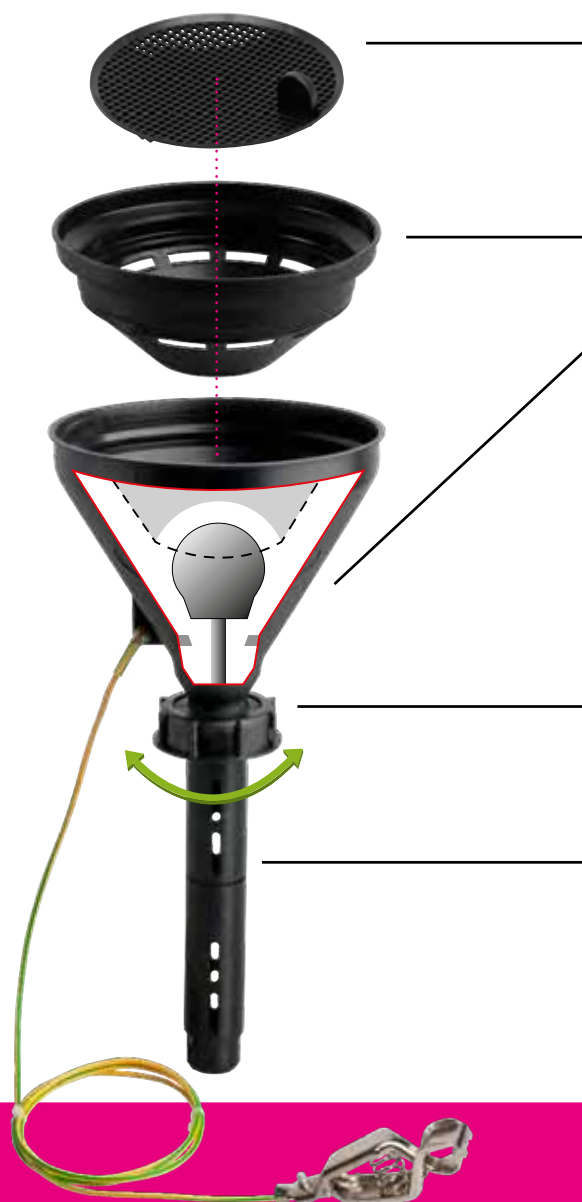

Sieve, removable

For trapping stirrers or larger contaminant particles. Now made of PE-HD instead of stainless steel, so no corrosion by acids or lyes.

Splash protection

For uniform discharge without splashes.

Ball valve

The ball floats and automatically closes after filling. For the disposal of small quantities and sticky liquid waste into the container, we recommend to rinse enough with water after using the funnel with ball valve, to prevent a potential sticking or sticking of the ball valve.

Freely rotatable cap

In different thread sizes for a wide variety of containers. You will find suitable canisters starting from Page 87.

Safety lance

Ensures clean outflow without contaminating the container opening. With electrically conductive funnels (black), the lance facilitates a safe additional grounding of the contents.

Safety funnels with hinged lid

- » Compact version optimally suited for restricted space conditions in the laboratory
- » Properly closed thanks to the hinged lid
- » Removable sieve for easy clean-up

This compact version with hinged lid is optimally suited for restricted space conditions in the laboratory. The sieve can be removed for cleaning. **(Funnels with hinged lid start from page 69).**

- » Angled adapter for canisters. Just place your laboratory bottles on the funnel-sieve and let them drip of easily.

Page 114



Hinged lid

For clean closure.

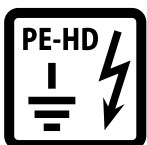

Electrostatic conductive PE-HD

All safety funnels in black (with ball valve or hinged lid) are made from electrostatically conductive PE-HD and have a ground connection to prevent ignition risks. The funnels are delivered with ground cable and clamp.



Safety funnels with ball valve

SAFETY FUNNELS

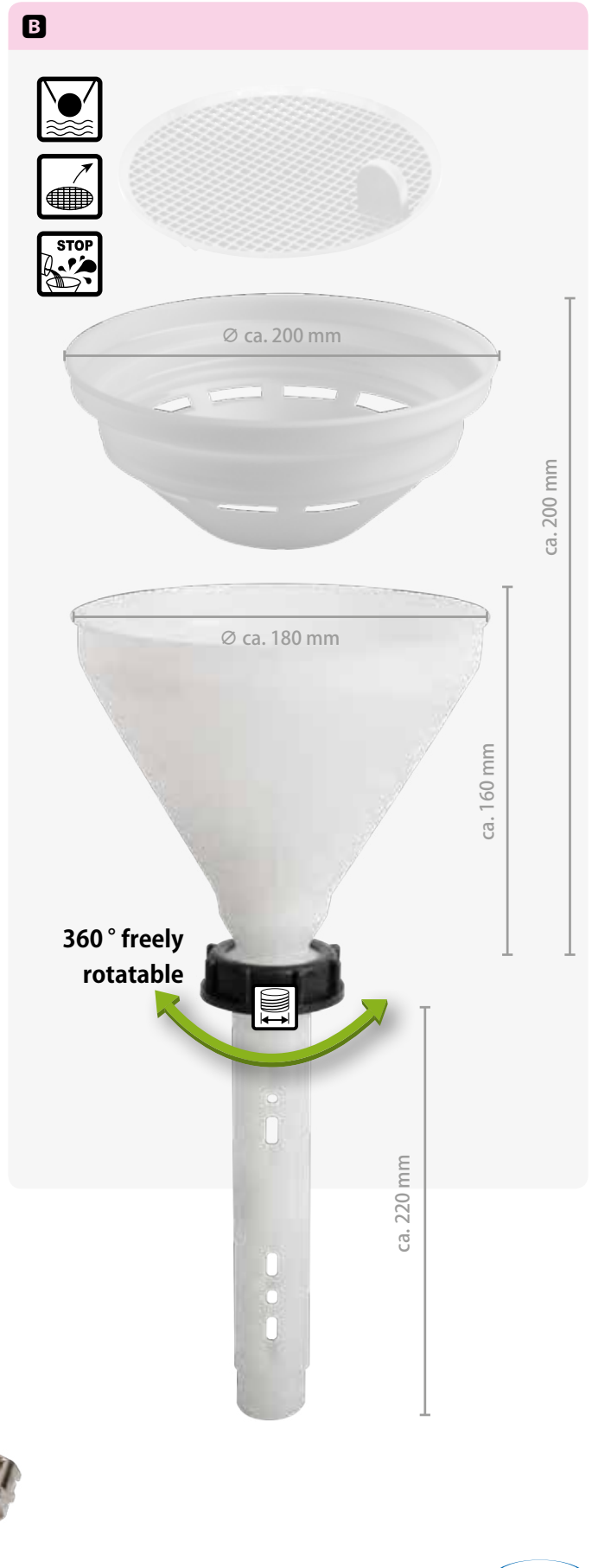

Safety funnels with ball valve



C 117 630



D 117 620



E 117 640

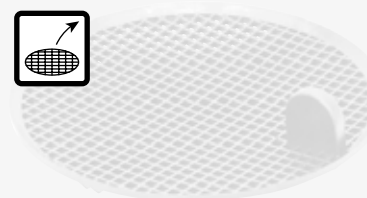

F 117 631



G 117 639



Scope of delivery

Incl. sieve and splash protection. Funnels in black are made from electrostatic conductive PE-HD and additionally equipped with grounding cable and clamp. These essential components can also be ordered individually (please see table below).

Type/Fig.	Part No.	Thread size	Description	Material
A	117 629	S 50	Safety funnel	PE-HD electrostatic conductive (black)
A	117 624	S 51	Safety funnel	PE-HD electrostatic conductive (black)
A	117 625	S 55	Safety funnel	PE-HD electrostatic conductive (black)
A	117 621	S 60/61	Safety funnel	PE-HD electrostatic conductive (black)
A	117 626	S 65	Safety funnel	PE-HD electrostatic conductive (black)
A	117 623	S 90	Safety funnel	PE-HD electrostatic conductive (black)
B	117 642	GL 45	Safety funnel	PE-HD (white)
B	117 649	S 50	Safety funnel	PE-HD (white)
B	117 644	S 51	Safety funnel	PE-HD (white)
B	117 645	S 55	Safety funnel	PE-HD (white)
B	117 641	S 60/61	Safety funnel	PE-HD (white)
B	117 643	S 90	Safety funnel	PE-HD (white)
C	117 630	R 2" BSP/G2" (m) + 2" Tri-Sure (m)	Safety funnel	PE-HD electrostatic conductive (black)
D	117 620	-	Sieve	PE-HD electrostatic conductive (black)
E	117 640	-	Sieve	PE-HD (white)
F	117 631	-	Splash protection	PE-HD electrostatic conductive (black)
G	117 639	-	Splash protection	PE-HD (white)
H	117 982	-	Ground cable with clamp	Copper cable (yellow with green coding)

Safety funnels with hinged lid

SAFETY FUNNELS



E 118 989

F 118 999

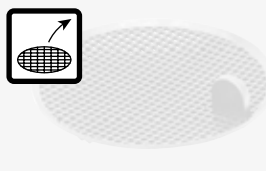
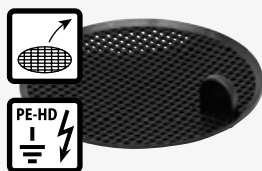

Scope of delivery

Incl. hinged lid and sieve. Funnels in black are made from electrostatic conductive PE-HD and additionally equipped with grounding cable and clamp. These essential components can also be ordered individually (please see table below).



Thread size

Type A
PE-HD-ec (black)
Safety lance
Ground connection

Type B
PE-HD (white)
Safety lance

Type C
PE-HD-ec (black)
Ground connection

Type D
PE-HD (white)

Thread size	Type A PE-HD-ec (black) Safety lance Ground connection	Type B PE-HD (white) Safety lance	Type C PE-HD-ec (black) Ground connection	Type D PE-HD (white)
GL 45	-	118 992	118 962	118 952
S 50	118 985	118 995	-	118 955
S 51	118 983	118 993	-	118 953
S 55	118 981	118 991	118 961	118 951
S 60/61	118 980	118 990	118 960	118 950
S 65	118 984	118 994	118 964	118 954

Fig.	Part No.	Description	Material
E	118 989	Sieve for safety funnel (black)	PE-HD electrostatic conductive (black)
F	118 999	Sieve for safety funnel (white)	PE-HD (white)
G	117 982	Ground cable with clamp	Copper cable (yellow with green coding)

Safety funnels with hinged lid



SAFETY FUNNELS

Fig.	Part No.	Thread size	Description	Material
H	117 633	GL 45	XL safety funnel with click-closure	PE-HD electrostatic conductive (black)
-	117 634	S 60/61	XL safety funnel with click-closure	PE-HD electrostatic conductive (black)
I	118 630	Doppelgewinde R 2" BSP/G2" + 2" Tri-Sure	Safety funnel with hinged lid	PE-HD electrostatic conductive (black)
J	160 555	-	Ventilation adapter for XL safety funnels	PE-HD electrostatic conductive (black)
K	108 670	Doppelgewinde R 2" BSP/G2" + 2" Tri-Sure	Safety funnel with hinged lid Sieve made from stainless steel	PE-HD (red)
-	108 670	S 60/61	Safety funnel with hinged lid Sieve made from stainless steel	PE-HD (red)
L	107 970	S 60/61	Safety funnel with hinged lid Safety lance made from stainless steel	Stainless steel

Safety funnels

Disposal units

Popular combinations!

In order to get your waste fluid collection site ready for operation quickly, we have put the most popular combinations together in a complete set.

- » Only one part number for the comprehensive safety system
- » No time consuming compilation of a configuration
- » Price advantage compared to ordering piece by piece
- » The delivery is made complete – the system is immediately ready for use

A 107 416

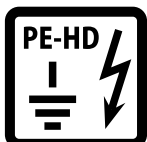

Electrostatic conductive PE-HD

All of our safety funnels in black (with ball valve or hinged lid), also canisters and collecting trays in black are made of electrostatic conductive PE-HD. Our disposal units perfectly protect from ignition risks.

Safety funnels Disposal units



Fig.	Part No. SET	Funnel	Container	Dimensions W x H x D (mm)
A	107 416	118 960 - Hinged lid - Sieve - PE-HD, electrostatic conductive - Ground cable	108 042 - 10 liter - PE-HD, electrostatic conductive - Floater for level control - with collecting tray 117 985	445 x 405 x 350
-	107 315	118 960 - Hinged lid - Sieve - PE-HD, electrostatic conductive - Ground cable	107 953 - 10 liter - PE-HD, electrostatic conductive - with collecting tray 117 985	445 x 405 x 350
B	107 320	117 621 - Ball valve - PE-HD, electrostatic conductive - Splash protection - Sieve - Ground cable	108 042 - 10 liter - PE-HD, electrostatic conductive - Floater for level control	210 x 460 x 430
C	107 321	117 621 - Ball valve - PE-HD, electrostatic conductive - Splash protection - Sieve - Ground cable	108 043 - 20 liter - PE-HD, electrostatic conductive - Floater for level control	210 x 710 x 430

Level control

Disposing with care

Everyday tasks in the laboratory that have become „The back of our hands“ – and we know, especially this is where the danger lurks. One of those seemingly trivial tasks is the disposal of solvents into the available containers.

Everybody uses them, everybody dumps into them, but who ensures that the containers don't overflow? However, overflowing waste containers in laboratories can be dangerous when work is done with critical substances and solvents. Dangerous fumes can spread fast. This is not only dangerous for individual health but under certain circumstances, can also lead to an explosion. Mechanically or electronically controlled containers provide more operational safety and protection from such serious consequences.

The level control developed by S.C.A.T. gives warning through an optical and acoustic signal before the waste container overflows. In addition, connecting devices such as pumps and valves can be actuated via contact switches.

Depending on demand, the different containers can be equipped either with non-contact sensors for exterior attachment or with float-controlled mechanical/optical and electronic/optical sensors. With the appendant electronic signal boxes, up to 5 containers can be monitored at the same time.

Liquid waste can be safely collected by tubes or manually; the sensor triggers an alarm if a critical fill level is reached. In addition, an integrated safety funnel can be attached to the safety cap. It is only opened during filling and closes automatically afterwards.

Running on empty can also cause damage

Also, in the opposite case, an empty level indicator might be required when the containers should not run empty. Some think timely refilling is sufficient and so undertake the risk, refilling might be forgotten. S.C.A.T. Europe offers just the right equipment for this.

All sizes of laboratory glass bottles, canisters, barrels and tank containers can be equipped with the system. Additional installations are not required for this. According to the motto: „Plug and Play“, every level control is delivered as fully operational and with all the necessary components.

A video says more than a thousand words

Many labs suffer from messy conditions when it comes to solvent and waste handling. The S.C.A.T. Europe team unveils the mistakes of the past and shows how to do it right.



**Just scan QR Code
and watch the Video.**



or directly visit: scat-europe.com/video

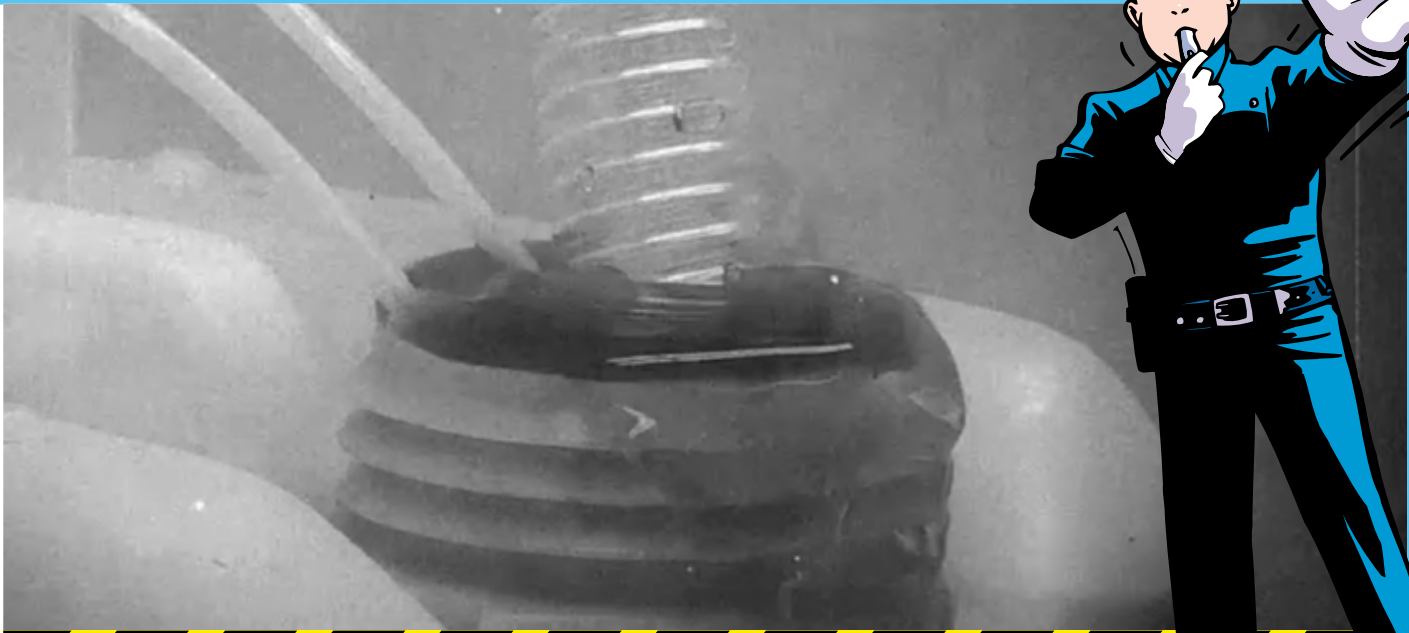

Overflowing containers - harmful and dangerous!



Safety Solution - S.C.A.T. Europe level control systems



Level control

Level control with disc sensor



- » Simple installation - for all typical containers made of glass or non-conductive plastic
- » Warning optionally at fill or low level
- » Sensitivity can be adjusted to different wall strengths

Fill level detection without touching the content of the container. The sensitivity of the sensor can be adjusted to different wall strengths. The signal box emits an optical and acoustic signal before a previously set fill height is reached. Suitable for all containers made of glass and non-conductive plastic. Just connect the sensor to the container wall at the desired fill level (fastening material is included with delivery), connect mains plug – done. No technical modifications to the receptacle are required.

Disc sensor for fill and low level control you will find on page 80.

Level control with SafetyWasteCap



- » Connect SafetyWasteCaps with electronic level control directly to a Signalbox
- » No additional sensor required
- » For containers made of conductive plastic and metal
- » Many thread sizes available

For containers made of conductive plastic or metal, the level control can be accomplished through the closure, there is no additional sensor required. The integrated floater transmits a signal to the connected Signalbox when the filling level has reached. All SafetyWasteCaps with the corresponding icon can be connected to our electronic signal boxes.

SafetyWasteCaps with electronic level control can be found starting from page 40.

Electronic signal boxes T1 and T5



- » Works with disc sensor and SafetyWasteCaps with electronic level control
- » Power and status LEDs, snooze and reset button, solid stand, space for labelling
- » Contact switch - control external devices such as pumps or valves due to potential-free contacts

Our electronic signal boxes alert through optical and acoustic warning signals about critical filling levels of your reservoirs and waste containers. Mute the alarm with the snooze and reset button, change the containers or fill up liquids, reset the signal box to reactivate the level control - you're done. Power and status LEDs inform you steadily about the operating state, the solid stand ensures safety at your laboratory work surface. Useful title blocks enable easy allocation of the connected containers.

The electronic Signalboxes for level control can be found starting from page 77.

Optical level control



- » Integrated optical level control
- » Container with viewing strip or floater
- » Made from electrostatic conductive PE-HD
- » Canister with UN approval - permitted for transport of hazardous goods on roads and plant premises

Safe collecting from liquid laboratory waste. The integrated floater or the viewing strip warn from critical filling levels and overflowing. Canisters in black are made from electrostatic conductive PE-HD. Our containers with viewing strip are additionally UN approved and permitted for transport of hazardous goods on roads and plant premises.

Suitable SafetyWasteCaps for waste containers can be found starting from page 35. Grounding accessories for containers starting from page 115.

Canisters with integrated level control you will find starting from page 83.

Level control Signalbox T1 and T5

A 108 087



Contact switch (potential-free contact)

For controlling external devices such as pumps or valves.

Signalbox T1 and T5

- Power and status LEDs
- "Snooze" & Reset button
- Solid stand
- Contact switch
- Useful space for labelling

B 108 088



Contact switch 1-5 and „ALL“ (potential-free contacts)

The Signalbox T5 can respond to single sensors. The output „ALL“ reacts to all connected sensors, regardless of their number or channel.

Compatible with switch amplifier

- Switch amplifier part no. 108 278
- Cable set part no. 108 219

Fig.	Part No.	Description	Connectors	Dimensions mm (W x H x D)	Incl. power supply
A	108 087	Signalbox T1	1	180 x 105 x 55	EU
B	108 088	Signalbox T5	5	180 x 105 x 55	EU
A	108 119	Signalbox T1	1	180 x 105 x 55	USA
B	108 121	Signalbox T5	5	180 x 105 x 55	USA
A	108 122	Signalbox T1	1	180 x 105 x 55	UK
B	108 124	Signalbox T5	5	180 x 105 x 55	UK



Level control Built-in Signalbox



SymLine[®]
Chemical Waste Systems
www.symline.de

NEW: Electronic built-in Signalbox²
Part No. 106 548

S.C.A.T. Europe's built-in series SymLine[®] offers an electronic Signalbox which can be included in to an allocated gap of your laboratory furniture front panel. Contact us or visit: www.SymLine.de

NEW AND IMPROVED DESIGN

- Touch control panel
- Level control through status LEDs, optical and acoustic alarm signals
- Compatible with switch amplifier, ATEX-compliant for use in explosion-endangered areas!



Level control Signalbox sets

A 108 125



1 x



1 x



1 x



1 x



LEVEL CONTROL

Fig.	Part No.	Description	Power supply
A	108 125	Signalbox T1 with disc fill level sensor , signal cable 3 meters, hook and loop fastener for disc sensor 2 meters	EU
A	108 157	Signalbox T1 with disc low level sensor , signal cable 3 meters, hook and loop fastener for disc sensor 2 meters	EU
-	108 158	Signalbox T1 with disc fill level sensor , signal cable 3 meters, hook and loop fastener for disc sensor 2 meters	USA
-	108 159	Signalbox T1 with disc low level sensor , signal cable 3 meters, hook and loop fastener for disc sensor 2 meters	USA
-	108 160	Signalbox T1 with disc fill level sensor , signal cable 3 meters, hook and loop fastener for disc sensor 2 meters	UK
-	108 161	Signalbox T1 with disc low level sensor , signal cable 3 meters, hook and loop fastener for disc sensor 2 meters	UK

Level control Accessories individual parts



- » The Signalbox T5 can observe up to 5 fill and low levels at the same time. Here you can find accessories for connection to your containers
- » Disc sensors for fill and low level control
- » Signal cable in several lengths: 3, 5 and 10 meters
- » Velcro or DualLock closure for mounting the disc sensor on containers



Fig.	Part No.	Description
A	108 048	Disc sensor (alarm at full state)
A	108 045	Disc sensor (alarm at empty state)
B	108 050	Signal cable, length 3 meters
-	108 037	Signal cable, length 5 meters
-	108 038	Signal cable, length 10 meters
C	900 108	Velcro strip for disc sensor, length 2 meters
-	900 107	Dual Lock (releasable pressure) closure for disc sensors, approx. 20 x 20 mm. Tougher and longer lasting than a conventional hook and loop fastener.
D	108 051	EU power supply
D	610 704	USA power supply
D	610 703	UK power supply

LEVEL CONTROL

Level control Switchbox

A 107 000



Electronic switchbox

Connected with the Signalbox T5 and the two SafetyWasteCaps with electronic level control, the box switches the 3-way ball tap via the output „switch out“.

B 160 178



3-way ball tap, electronically controllable

Connected with the Switchbox, this 3-way ball tap receives a signal to interrupt the influent flow to the already filled container and to bypass to the empty reserve container.

- » Long time secured from overflow with the reserve canister
- » The disposal can run carefree over the night or the weekend, without emptying or changing of the filled container
- » Compatible with all S.C.A.T. SafetyCaps with electronic level control and disc sensors
- » Many more capabilities, not only for waste disposal of HPLC systems

Fig.	Part No.	Description
A	107 000	Electronic Switchbox
B	160 178	3-way ball tap, electronically controllable

Level control Switchbox

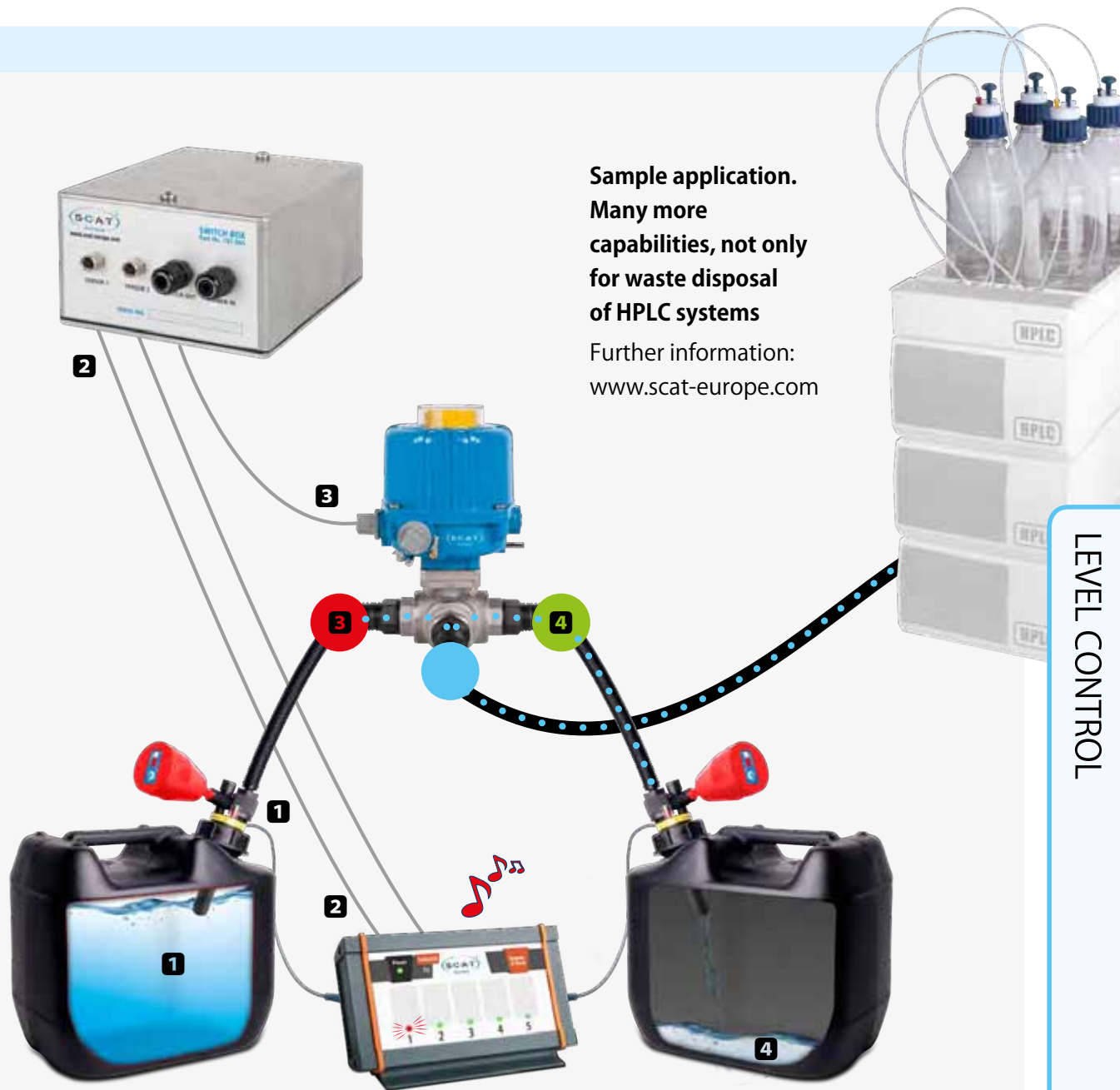

Sample application.
Many more
capabilities, not only
for waste disposal
of HPLC systems

Further information:
www.scateurope.com

LEVEL CONTROL

1 Container filled

The SafetyWasteCap with electronic level control transfers a signal to the connected Signalbox T5.

2 Signalbox

The electronic Signalbox transfers the signal to the connected Switchbox.

3 Switchbox

The Switchbox triggers the connected 3-way ball tap.

4 Bypass

The 3-way ball tap closes the influent flow of liquid waste to the filled container and bypass to the connected reserve canister.

Level control

Containers with integrated level control

A 108 945



S 50



B 108 421



S 50



With viewing strip.

Level control without floater!
Our canisters with viewing strip are **UN-approved**. They are permitted for transport of hazardous goods on roads and plant premises.

Have an eye on filling levels

Safely collect fluid laboratory waste! The integrated floater gives a warning in time to prevent overfilling. Ideal for use with S.C.A.T safety funnels (starting from page 67).

Electrostatic conductive PE-HD

Canisters in black are made from electrostatic conductive PE-HD.

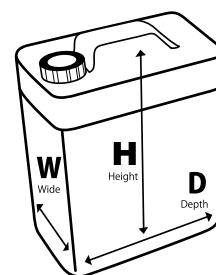

Thread

Dimensions
W x H x D (mm)



UN approval

Fig.	Part No.	Description	Contents	Material	Thread	Dimensions W x H x D (mm)	UN approval
A	108 945	Space-saving canister with floater	5 liter	PP, white	S 50	65 x 405 x 330	-
B	108 421	Canister with viewing strip	10 liter	PE-HD, black electrostatic conductive	S 50	200 x 320 x 240	●
C	108 420	Canister with viewing strip	10 liter	PE-HD, black electrostatic conductive	S 90	195 x 400 x 195	●
D	108 042	Canister with floater	10 liter	PE-HD, black electrostatic conductive	S 60 / 61	185 x 280 x 290	-
E	108 043	Canister with floater	20 liter	PE-HD, black electrostatic conductive	S 60 / 61	185 x 515 x 290	-
-	107 740	Canister with floater	60 liter	PE-HD, black electrostatic conductive	S 70 / 71	330 x 690 x 395	-
F	199 013	Protective cage for floater (white)					-
-	199 005	Protective cage for floater (black)					-

Level control Containers with integrated level control

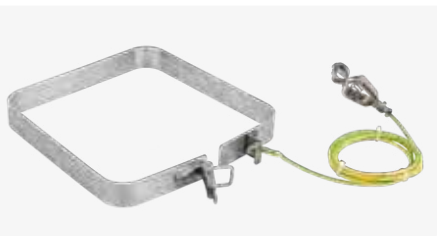

Ground strap for S90 canister with viewing strip

This canister has to be grounded by the ground strap for canisters. Canister strap and further grounding accessories on page 116.



LEVEL CONTROL

Level control for barrels

Level control for barrels.

Dependable protection from overflow when filling barrels. Practical, large handle for simple handling, even with gloves. The float positions itself securely at the opening by its own weight while the barrel fills up. The integrated ventilation ensures a safe pressure equalization.

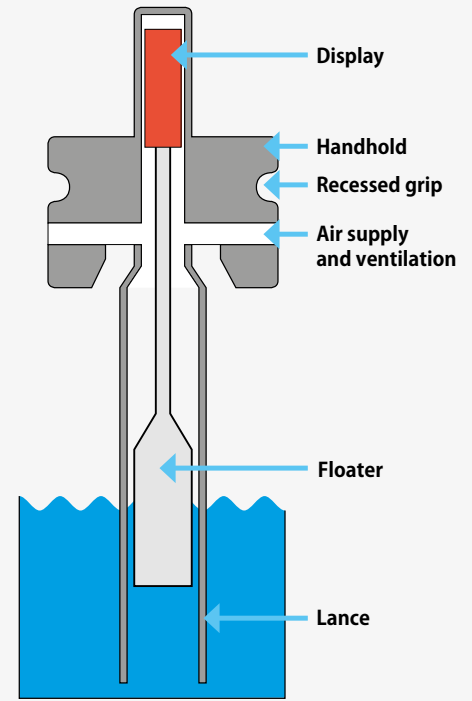

Exhaust filters for barrels you will find on page 60 and 103.

LEVEL CONTROL

A 107 885



Thread adapter with level control.

Adapter for funnel with mechanical level control, available in several thread sizes (see chart) with M12x1 connection for mechanical level control, conductive, bicoloured red/green, with knurled handle.



Fig.	Part No.	Description
A	107 885	Double thread R 2" BSP/G2 + 2" Tri-Sure (m) to GL 45 (m)
-	107 886	2" Mauser (m) to GL 45 (m)
-	107 889	S 60 (f) to GL 45 (m)

Level control for barrels

B 100 703

C 107 880

D 107 881

E 107 883



For all openings from 50 mm diameter

For 3/4" thread

XXL level control

- Dependable fill level control for containers up to 200 liters
- Ideal for safe barrel filling
- Available in different materials, therefore suitable for all chemicals

Fig.	Part No.	Description	Lance length	Lance diameter	Material
B	100 703	Level control for barrels with milk pipe thread	250 mm	31 mm	Lance: PE-HD, black Floater: PE-HD, black Display: ETFE, red
C	107 880	Level control for barrels (fits all openings from Ø 50 mm) (up to max. Ø 100 mm)	250 mm	50 mm	Lance: PE-HD, black Floater: PE-HD, black Display: ETFE, red
D	107 881	Level control for barrels (fits all openings from Ø 50 mm) (up to max. Ø 100 mm)	250 mm	50 mm	Lance: PTFE, white Floater: PFA, white Display: ETFE, red
E	107 883	Level control for barrels Thread G3/4"	86 mm	18 mm	PE-HD electrostatic conductive
-	107 882	Level control for barrels Thread G3/4"	86 mm	18 mm	PE-HD
-	107 884	Level control for barrels Thread G3/4"	150 mm	18 mm	Lance: PTFE, white Floater: PFA, white Display: PE, red

Containers

Containers for all purposes – suitable for S.C.A.T. safety system

S.C.A.T. safety closures are available for a wide range of different container threads. On the following pages, you will find the suitable containers for every thread size. If you wish to use already available containers, we are providing you with an aid in determining thread size here.

Note: All specified values are for orientation and may vary from manufacturers' specifications by 0.5 mm (due to production tolerances).



Screw cap

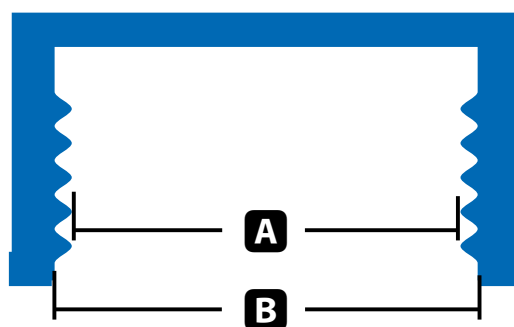

Thread

Thread	∅ A	∅ B
GL 28	ca. 26 mm	ca. 27.5 mm
GL 32	ca. 29.5 mm	ca. 31.5 mm
GL 38	ca. 35.5 mm	ca. 37 mm
GL 40	ca. 38 mm	ca. 40 mm
GL 45	ca. 41.5 mm	ca. 45 mm
S 50	ca. 45.5 mm	ca. 51.5 mm
S 51	ca. 45.5 mm	ca. 50 mm
B 53	ca. 50.5 mm	ca. 54.5 mm
S 55	ca. 50.5 mm	ca. 55 mm
S 60 / 61	ca. 55.5 mm	ca. 61 mm
B 63	ca. 58.5 mm	ca. 63 mm
S 65	ca. 62 mm	ca. 65.5 mm
S 70 / 71	ca. 66 mm	ca. 71.5 mm
GLS 80	ca. 78 mm	ca. 83 mm
B 83	ca. 83 mm	ca. 90 mm
S 90	ca. 85 mm	ca. 90.5 mm
S 95	ca. 90 mm	ca. 96.5 mm

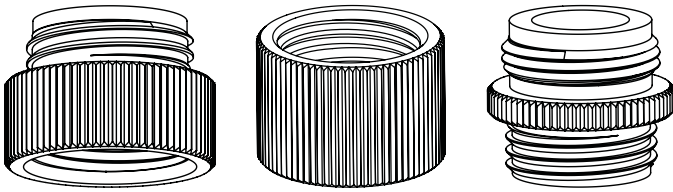

If it doesn't fit – we'll make it fit!

S.C.A.T. Europe offers a huge range of accessories and adapters. All informations regarding our thread adapters you will find on page 113 - 114.

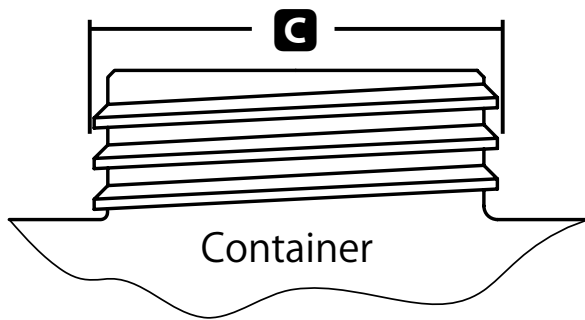

∅ **G**

ca. 28 mm
ca. 31.5 mm
ca. 37.5 mm
ca. 40 mm
ca. 44.5 mm
ca. 50 mm
ca. 48 mm
ca. 53 mm
ca. 53.5 mm
ca. 59 mm
ca. 62 mm
ca. 64.5 mm
ca. 70 mm
ca. 80 mm
ca. 88 mm
ca. 88 mm
ca. 94 mm

Additional identifying features

Narrow mouth thread
Often brown glass bottles
For containers of the brands Wheaton® and NALGENE®
For containers of the brand MERCK®
Established thread of laboratory bottles
For space-saving canisters
Nearly identical to S 50. Only the outer diameter (OD) of the container thread is significantly different.
For containers of the brand NALGENE®
The number 51 is often in the cover
The number 61 is often in the cover
For containers of the brand NALGENE®
For containers of the brand KAUTEX®
The number 71 is often in the cover
Established laboratory wide neck opening bottle
For containers of the brand NALGENE®
The number D90 is often in the cover
e.g. S.C.A.T. Europe canister part number 107 707, page 96

Containers

Lab bottles



GL 45



A



B



C

Lab bottles – round

We offer contents from 250 ml **up to 10,000 ml**. Clear glass and optional with protective coating. See chart.



X



GL 45



D



E

NEW: Duran® YOUTILITY

Ergonomically design simplifies the grasp of lab bottles. Changeable and coloured rubber rings at the bottleneck are some clever marking-labels to get organised in the lab.

Square

We offer contents from 250 ml, 500 ml and 1,000 ml. See chart.



GL 45



F



G



H

Brown glass

We offer contents from 250 ml, 500 ml and 1,000 ml. See chart.



GLS 80

Wide neck opening

GLS 80 lab bottles with wide neck opening



L 501 122



Ground neck 29/32



Fig.	Part No.	Description	Content	Glass type	Form	Thread
-	501 126	DURAN® laboratory bottle	10,000 ml	Clear glass	round	GL 45
-	501 125	DURAN® laboratory bottle	5,000 ml	Clear glass	round	GL 45
A	501 118	DURAN® laboratory bottle	2,000 ml	Clear glass	round	GL 45
B	501 113	DURAN® laboratory bottle	1,000 ml	Clear glass	round	GL 45
-	501 116	DURAN® laboratory bottle	500 ml	Clear glass	round	GL 45
C	501 117	DURAN® laboratory bottle	250 ml	Clear glass	round	GL 45
-	101 998	DURAN® laboratory bottle with protective coating	5,000 ml	Clear glass	round	GL 45
-	101 997	DURAN® laboratory bottle with protective coating	2,000 ml	Clear glass	round	GL 45
-	101 996	DURAN® laboratory bottle with protective coating	1,000 ml	Clear glass	round	GL 45
-	101 995	DURAN® laboratory bottle with protective coating	500 ml	Clear glass	round	GL 45
-	101 994	DURAN® laboratory bottle with protective coating	250 ml	Clear glass	round	GL 45
D	501 110	DURAN® laboratory bottle	1,000 ml	Clear glass	square	GL 45
-	501 115	DURAN® laboratory bottle	500 ml	Clear glass	square	GL 45
E	501 112	DURAN® laboratory bottle	250 ml	Clear glass	square	GL 45
F	501 119	DURAN® laboratory bottle	1,000 ml	Brown glass	round	GL 45
G	501 120	DURAN® laboratory bottle	500 ml	Brown glass	round	GL 45
H	501 121	DURAN® laboratory bottle	250 ml	Brown glass	round	GL 45
I	501 158	DURAN® laboratory bottle with wide neck opening	2,000 ml	Brown glass	round	GLS 80
-	501 157	DURAN® laboratory bottle with wide neck opening	1,000 ml	Brown glass	round	GLS 80
-	501 156	DURAN® laboratory bottle with wide neck opening	500 ml	Brown glass	round	GLS 80
-	501 152	DURAN® laboratory bottle with wide neck opening	2,000 ml	Clear glass	round	GLS 80
J	501 151	DURAN® laboratory bottle with wide neck opening	1,000 ml	Clear glass	round	GLS 80
K	501 150	DURAN® laboratory bottle with wide neck opening	500 ml	Clear glass	round	GLS 80
L	501 122	DURAN® laboratory bottle with ground neck	1,000 ml	Clear glass	round	NS 29/32
-	501 127	DURAN® laboratory bottle for MiniCap GL28	100 ml	Brown glass	round	GL 28
X	501 131	DURAN® laboratory bottle YOUTILITY	1,000 ml	Clear glass	ergo	GL 45

Containers Canisters



GL 45



S 50

Space-saving canister
Only 65 mm wide!



CONTAINERS

G 107 958



S 51



H 107 711



B 53



I 107 957



S 55



Canisters

GL 45, S 50, S 51, B 53, S 55

Add to your order - Base for 2 space-saving canisters

Part number 199 050.



Dimensions W x H x D (mm)
145 x 130 x 200

F 108 421



S 50



Viewing strip
Level control
without floater!



UN approval

Canisters with UN approval are permitted for transport of hazardous goods on roads and plant premises.

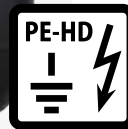

Electrostatic conductive PE-HD

Canisters in black are made of electrostatic conductive PE-HD.

Fluorinated canister 107 933

against weight loss of content. Fluorination on both sides protect the canisters plastic walls from permeation of chemicals.

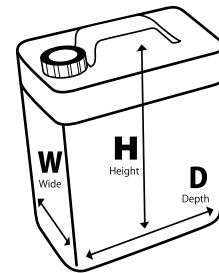

Fig.	Part No.	Description	Content	Material	Thread	Dimensions W x H x D (mm)	UN approval
A	107 950	Canister	2.5 l	PE-HD	GL 45	115 x 210 x 150	●
B	107 951	Canister	5 l	PE-HD	GL 45	150 x 250 x 195	●
C	107 952	Canister	10 l	PE-HD	GL 45	190 x 305 x 230	●
D	107 998	Space-saving canister	5 l	PP	S 50	65 x 335 x 330	-
E	108 945	Space-saving canister with floater	5 l	PP	S 50	65 x 405 x 330	-
F	108 421	Canister with viewing strip	10 l	PE-HD-ec	S 50	200 x 320 x 240	●
G	107 958	Canister	5 l	PE-HD	S 51	145 x 250 x 190	●
H	107 711	Round canister	2 l	PE-HD	B 53	119 x 260 x 119	-
I	107 957	Canister	5 l	PE-HD	S 55	160 x 230 x 185	●
-	107 933	Canister fluorinated	5 l	F-HDPE	S55	145 x 250 x 190	●
-	107 955	Canister	10 l	PE-HD	S 55	185 x 305 x 225	●

Containers Canisters

A 107 956



ColourLine
Canisters with colour marking at the grip.



Level control
Integrated floater.



CONTAINERS

Canisters

S 60 / 61, B 63, S 65

K 108 115



S 60 / 61

Double closure
Re-filling during regular operation.

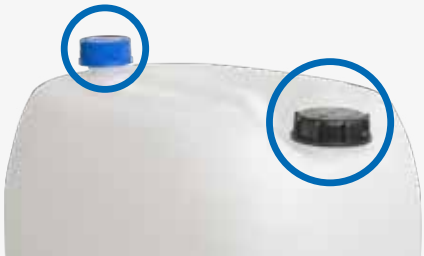

L 107 709



B 63

Flat canister
Space-saving thanks to the low height.

S 65

M **N**



Electrostatic conductive PE-HD

Canisters in black are made of electrostatic conductive PE-HD.

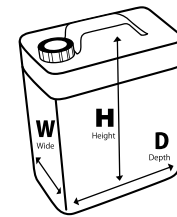

Fig.	Part No.	Description	Content	Material	Thread	Dimensions W x H x D (mm)	UN approval
A	107 956	Canister	20 l	PE-HD	S 60 / 61	260 x 390 x 289	●
-	107 731	Canister	12 l	PE-HD	S 60 / 61	200 x 350 x 235	●
-	107 959	Canister	30 l	PE-HD	S 60 / 61	290 x 400 x 380	●
B	107 953	Canister	10 l	PE-HD-ec	S 60 / 61	185 x 265 x 290	●
C	108 027	Canister	20 l	PE-HD-ec	S 60 / 61	185 x 500 x 290	●
D	108 192	Canister	30 l	PE-HD-ec	S 60 / 61	240 x 450 x 380	●
E	108 214	Canister ColourLine blue	10 l	PE-HD-ec	S 60 / 61	185 x 265 x 290	-
F	108 215	Canister ColourLine yellow	10 l	PE-HD-ec	S 60 / 61	185 x 265 x 290	-
G	108 216	Canister ColourLine red	10 l	PE-HD-ec	S 60 / 61	185 x 265 x 290	-
H	108 217	Canister ColourLine green	10 l	PE-HD-ec	S 60 / 61	185 x 265 x 290	-
-	108 193	Canister with floater	30 l	PE-HD-ec	S 60 / 61	240 x 450 x 380	-
I	108 042	Canister with floater	10 l	PE-HD-ec	S 60 / 61	185 x 265 x 290	-
J	108 043	Canister with floater	20 l	PE-HD-ec	S 60 / 61	185 x 500 x 290	-
K	108 115	Canister with double closure	30 l	PE-HD	S 60 / 61 + GL 45	300 x 450 x 400	-
L	107 709	Flat canister with drain valve	8 l	PP	B 63	375 x 165 x 305	-
M	107 722	Round canister	5 l	PE-HD	S 65	167 x 330 x 167	-
N	107 704	Round canister	10 l	PE-HD	S 65	205 x 430 x 205	-
-	107 720	Round canister	25 l	PE-HD	S 65	278 x 580 x 278	-
-	107 721	Round canister	60 l	PE-HD	S 65	350 x 825 x 350	-

Containers Canisters



S 70 / 71



G 107 940



S 70 / 71



B 83



Electrostatic conductive PE-HD

Canisters in black are made of electrostatic conductive PE-HD.



UN approval

Canisters with UN approval are permitted for transport of hazardous goods on roads and plant premises.

Canisters

S 70 / 71, B 83, S 90, S 95



Viewing strip
Level control without floaters!

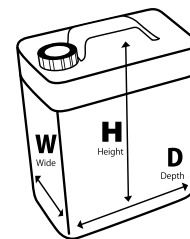

Fig.	Part No.	Description	Content	Material	Thread	Dimensions W x H x D (mm)	UN approval
A	107 713	Flat canister	20 l	PE-HD	S 70/71	285 x 285 x 380	●
B	107 710	Canister	60 l	PE-HD	S 70/71	345 x 645 x 395	●
C	107 940	Canister	60 l	PE-HD-ec	S 70/71	330 x 630 x 400	●
-	107 740	Canister with floater	60 l	PE-HD-ec	S 70/71	330 x 690 x 395	-
D	107 712	Round canister	4 l	PE-HD	B 83	155 x 338 x 155	-
E	107 706	Round canister with carrying handle	10 l	PP	B 83	250 x 390 x 250	-
-	107 730	Round canister with carrying handle (autoclavable)	50 l	PP	B 83	380 x 680 x 380	-
F	108 020	Canister	10 l	PE-HD	S 90	195 x 380 x 195	●
G	108 420	Canister with viewing strip	10 l	PE-HD-ec	S 90	195 x 380 x 195	●
H	107 707	Canister	5 l	PE-HD	S 95	170 x 310 x 170	●
-	107 733	Canister	20 l	PE-HD	S 95	260 x 390 x 290	-

Container accessories

Politainer, spouts

A 107 330



Space saving storage

The Politainer can ideally be stored space-saving prior to filling and it is stackable when filled. The Politainers unfolds automatically during filling – the integrated handle ensures a safe transport and emptying free of danger. Through the small volume in its original condition you save shipping costs. The carton can be used several times and that increases cost effectiveness. The combi-packaging uses 50% – 75% less material than rigid container and is therefore environmentally friendly. When using the strong covering box the Politainer is UN approved.



UN approval

Fig.	Part No.	Description	Volume	Dimensions W x H x D (mm)	Thread	UN approval
A	107 330	Politainer	5 l	178 x 178 x 178	GL 38	-
-	107 331	Politainer	10 l	228 x 228 x 228	GL 38	-
-	107 332	Politainer	10 l	228 x 228 x 228	S 60	-
-	107 333	Politainer	20 l	285 x 285 x 285	S 60	-
-	107 334	Box for politainer	for 5 l	189 x 186 x 190	-	●
-	107 335	Box for politainer	for 10 l	236 x 236 x 236	-	●
-	107 336	Box for politainer	for 20 l	290 x 290 x 306	-	●
-	107 338	Thread adapter PTFE			GL 38 (f) to GL 45 (m)	-
-	107 339	Thread adapter PE			GL 38 (f) to GL 45 (m)	-

B 610 499



C 610 500



D 610 502



E 610 504



Fig.	Part No.	Description	Thread
B	610 499	Flexible spout, with safety vent	S 55
-	610 501	Flexible spout, with safety vent	S 60 / 61
-	610 503	Flexible spout, with safety vent	S 70 / 71
C	610 500	Rigid spout, with safety vent	S 55
D	610 502	Rigid spout	S 60 / 61
E	610 504	Rigid spout, electrostatic conductive PE-HD	S 60 / 61

Container accessories

Collecting trays



Connection for ground cables
Ground cables you will find on page 115.

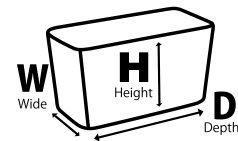

Fig.	Part No.	Description	Material	Dimensions, inner W x H x D (mm)	Dimensions, outer W x H x D (mm)
A	117 983	Collecting tray	PE-HD	235 x 160 x 335	300 x 170 x 400
B	117 984	Collecting tray	PE-HD	290 x 200 x 385	340 x 210 x 465
C	108 981	Collecting tray	PE-HD-ec	200 x 200 x 300	225 x 215 x 325
D	117 986	Collecting tray with base insert	PE-HD-ec	295 x 200 x 415	365 x 240 x 490
E	117 985	Collecting tray with base insert	PE-HD-ec	285 x 95 x 385	355 x 135 x 445

Accessories around canisters:

Safety funnels
from page 67

Canister with integrated floater
on pages 83, 84 and 93

Grounding accessories
from page 115

Collecting trays
Page 98

Anti-static mat
Page 116



Accessories

Accessories matching with the S.C.A.T. safety system

- » We have developed a lot of products, which you need to be able to work quickly, safely and economically
- » All products are specially matched with the S.C.A.T. safety system
- » High quality accessories which are well-proven in practice

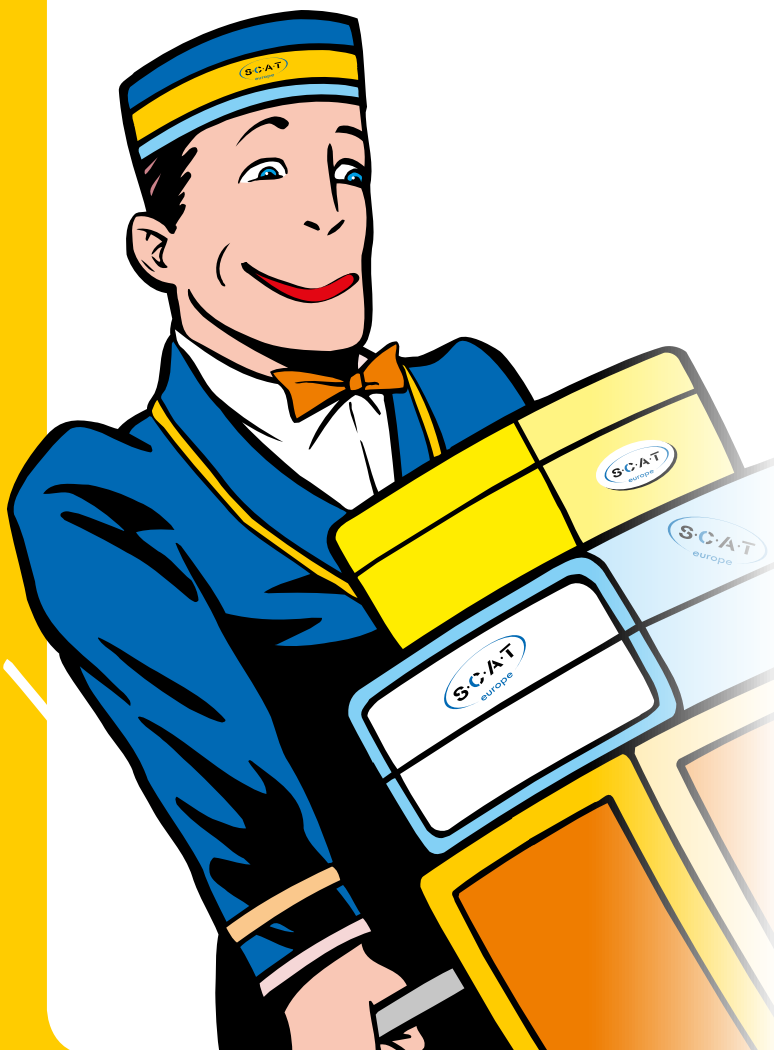

Refresh used air valves and exhaust filters regularly



Blocked dust particles

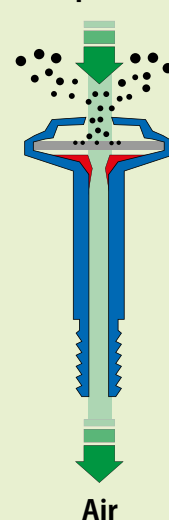

Air

Blocked Vapors / gases

Filtered exhaust air



Vapors / gases

Air valves for SafetyCaps



- » Ventilation of the bottle during operation and extraction of solvents
- » Variations for the preparative HPLC with supply rates of up to 400 ml/min.
- » Valves from fire-resistant material also available

The air valve combines valve and filter functions. As usual, ventilation occurs during extraction; harmful solvent vapors are blocked. At the same time, the valve membrane absorbs dust and contaminant particles from the incoming air. The valve also fits your existing S.C.A.T SafetyCaps without any technical modification.

Since the filter membrane absorbs contaminants from the surrounding air, it is necessary that the valve be replaced regularly in order to ensure flawless operation.

Air valves you will find on page 101.

Exhaust filters for SafetyWasteCaps



- » Central element of S.C.A.T. Europe's waste system
- » Cleans solvent vapors from the exhaust air
- » The useful change indicator is activated at the push of a button

Exhaust filters keep your workspace safe and clean. The exhaust filter is a central element of the S.C.A.T. safety system, they clean solvent vapors from the exhaust air.

Exhaust filters are permanently exposed to vapors, dust particles and pollutants. Exchange saturated filters within their service life to maintain your workspace safety. With the useful change indicator the inspection is easier than ever before.

Exhaust filters starting from page 102.



Accessories

Air valves for SafetyCaps

A 117 010

6 Months



Up to 150 ml/min.



B 112 010

6 Months



Up to 150 ml/min.



C 117 011

6 Months



Up to 400 ml/min.



Functionality of the air valve

Clearly explained on page 4.



Change every 6 months

Since the filter membrane absorbs contaminants from the surrounding air, it is necessary that the valve be replaced every 6 months in order to ensure flawless operation.



The change-advice-label

Never miss a change again! The writable change-advice-label is already installed at the air valve (blue) / included in scope of delivery.

Fig.	Part No.	Description	Unit
A	117 010	Air valve for SafetyCaps (150 ml/min.)	1
A	197 010	Air valve for SafetyCaps (150 ml/min.)	10
A	197 050	Air valve for SafetyCaps (150 ml/min.)	50
B	112 010	Air valve for SafetyCaps, fire-resitant (150 ml/min.)	1
B	112 110	Air valve for SafetyCaps, fire-resitant (150 ml/min.)	10
C	117 011	Air valve for SafetyCaps, preparative (400 ml/min.)	1
C	197 011	Air valve for SafetyCaps, preparative (400 ml/min.)	10

Accessories Exhaust filter for SafetyWasteCaps



Functionality of the air valve

Clearly explained on page 27.



Change every 3 or 6 months

Exhaust filters are permanently exposed to vapors, dust particles and pollutants. Exchange saturated filters within their service life to maintain your workspace safety.

Larger exhaust filters (volume-optimized, recommended for waste containers with a volume of more than 20 liters), made from fire-resistant material and variations for barrels:

On pages 59, 60 and on the next side 103.

The change indicator

Activate the integrated change indicator easily by a single push of a button. The indicator will signalize if a change becomes necessary.

Fig.	Part No.	Filter size	Recommended for waste containers with a volume of...	Accessories	Service life	Unit
A	610 534	S (small)	up to 5 liters	Splash protection with change indicator	3 Months	1
B	610 535	M (medium)	up to 20 liters	Splash protection with change indicator	6 Months	1
C	190 335	S (small)	up to 5 liters	Splash protection with change indicator	3 Months	4
D	190 336	M (medium)	up to 20 liters	Splash protection with change indicator	6 Months	3



Accessories

more exhaust filters for SafetyWasteCaps and exhaust filters for barrels

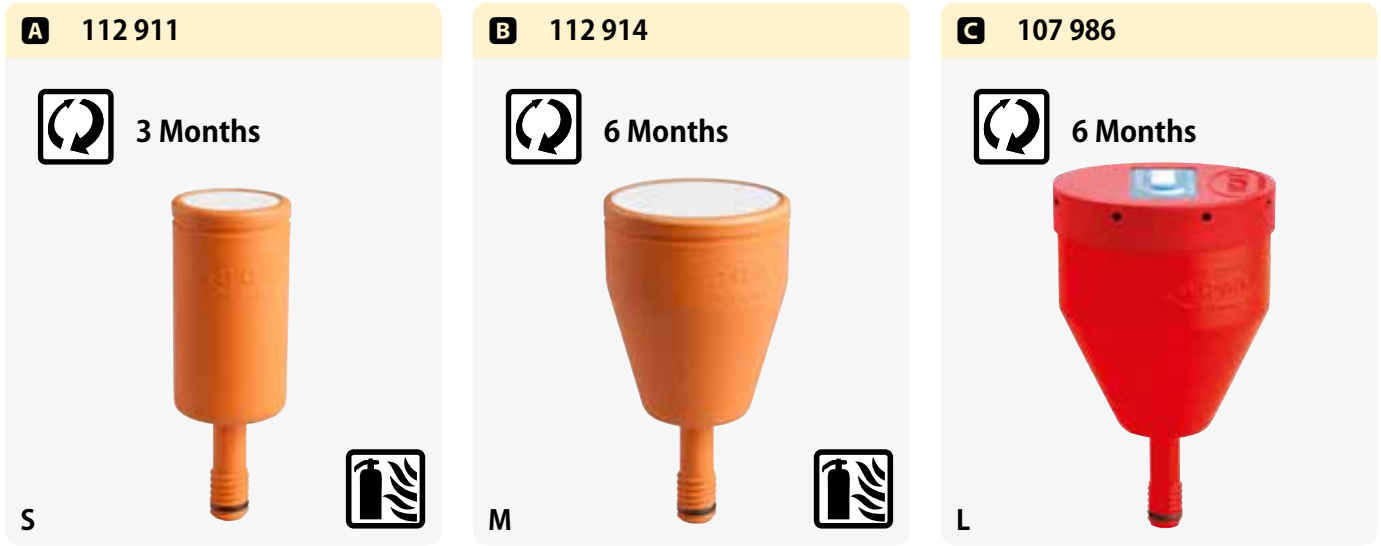

Fig.	Part No.	Filter size	Recommended for waste containers with a volume of...	Accessories	Service life	Unit
A	112 911	S (small)	up to 5 liters	Fire-resistant	3 Months	1
B	112 914	M (medium)	up to 20 liters	Fire-resistant	6 Months	1
C	107 986	L (large)	more than 20 liters	Splash protection with change indicator	6 Months	1



Exhaust filters for barrels



Fig.	Part No.	Filter size	Fill amount	Thread size	Recommended for barrel size	Service life	Unit
E	108 985	XL	520 g	G 3/4"	60 - 100 liters	9 Months	1
F	108 986	XXL	990 g	2" Mauser (BCS 70x6)	from 100 liters	12 Months	1
-	108 987	XXL	990 g	Double thread R 2" BSP/G2" + 2" Tri-Sure	from 100 liters	12 Months	1

ACCESSORIES

Accessories Accessories for the exhaust filter connector



Space problems? Offset adapter!

Space problem in the lab? Not an issue – attach the exhaust air filter to the waste containers in any position. Practical, space-saving and flexible. With the extension **A**, you can create more freedom of movement when attaching tubes. The adapters **A B C D** can be combined with each other.

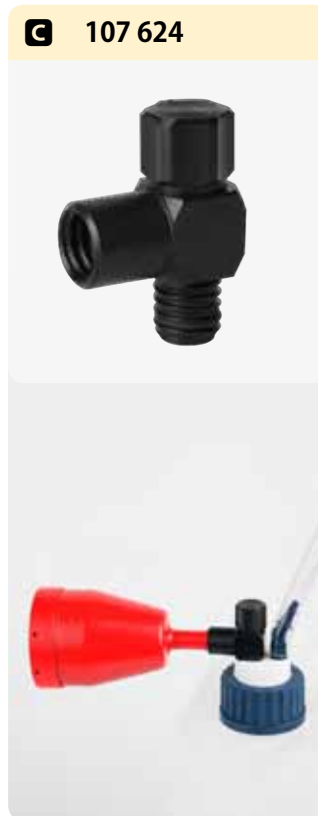

Fig.	Part No.	Description	Unit
A	107 621	Extension piece	1
B	107 622	Right offset adapter	1
C	107 624	90° adapter for angled connection	1
D	107 627	45° adapter for angled connection	1
E	107 620	Blind plug for exhaust filter connector	1
F	107 632	Adapter capillary connector to exhaust filter connector	1



ACCESSORIES



Accessories

Fittings for the capillary connector

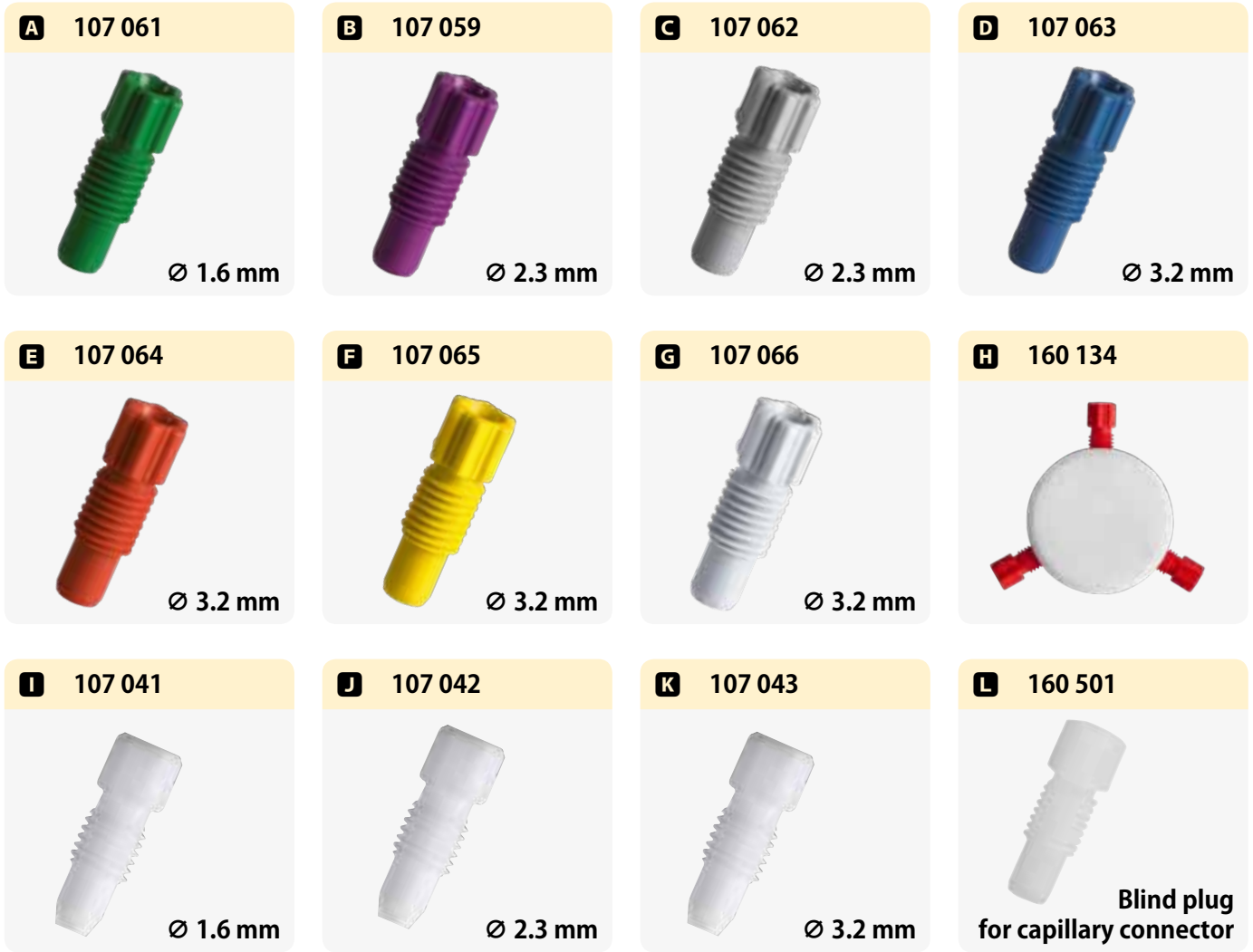

Fig.	Part No.	Description	Capillary size Ø OD	Material	Color	Unit
A	107 061	Fitting for capillary connector	1.6 mm	PFA	Green	5
-	107 048	Fitting for capillary connector	1.6 mm	PFA	Colorless	5
B	107 059	Fitting for capillary connector	2.3 mm	PFA	Violet	5
C	107 062	Fitting for capillary connector	2.3 mm	PFA	Grey	5
-	107 060	Fitting for capillary connector	3.2 mm	PFA	Black	5
D	107 063	Fitting for capillary connector	3.2 mm	PFA	Blue	5
E	107 064	Fitting for capillary connector	3.2 mm	PFA	Red	5
F	107 065	Fitting for capillary connector	3.2 mm	PFA	Yellow	5
G	107 066	Fitting for capillary connector	3.2 mm	PFA	Neutral	5
H	160 134	Distributor, 3-way for capillary connector	2.3 / 3.2 mm	PTFE/PFA	White/Red	1
I	107 041	Fitting for capillary connector	1.6 mm	PTFE	White	10
J	107 042	Fitting for capillary connector	2.3 mm	PTFE	White	10
K	107 043	Fitting for capillary connector	3.2 mm	PTFE	White	10
L	160 501	Blind plug for capillary connector	-	PFA	Colorless	10

ACCESSORIES

Accessories

Fittings for the capillary connector



M 117 816



1:1

Tube fitting for the capillary connector

Connect a tube to the capillary connector?

No problem, the tube fitting 117 816 has the proper thread.

Fig.	Part No.	Description	For tube diameter	Material	Color	Unit
M	117 816	Tube fitting, straight	6 - 8 mm ID	PP	Neutral	1

» Accessories for the preparative HPLC

N 107 045

For SafetyCap:
108 032
109 032
110 032

Ø 4.76 mm
(3/16")

O 160 503

For SafetyCap:
108 032
109 032
110 032

Blind plug
Ø 4.76 mm
(3/16")

P 107 044

For SafetyCap:
107 007
107 008
107 009

Ø 6.35 mm
(1/4")



ACCESSORIES

Please note:

Accessories for the preparative HPLC (SafetyCaps for the preparative HPLC you will find on page 7 and 8).

These fittings only match with SafetyCaps for the preparative HPLC. They are not capable for the standard capillary connector.

Fig.	Part No.	Description	Capillar size Ø OD	Material	Color	Unit
-	107 047	Fitting for preparative HPLC	4.0 mm	PTFE	White	1
N	107 045	Fitting for preparative HPLC	4.76 mm (3/16")	PTFE	White	1
O	160 503	Blind plug for preparative HPLC	4.76 mm (3/16")	PTFE	White	10
-	160 515	Blind plug for preparative HPLC	4.76 mm (3/16")	PTFE	White	5
-	107 046	Fitting for preparative HPLC	6.0 mm	PTFE	White	1
P	107 044	Fitting for preparative HPLC	6.35 mm (1/4")	PTFE	White	1



Accessories

Tube fittings for the tube connector



Images A - K shown on a scale of 1:1
 Just add the tube and identify the suitable fitting.

Fig.	Part No.	Description	For tube diameter	Material	Unit
A	117 808	Stepped fitting, curved	6.4 - 9 mm ID	PP	1
B	160 143	Tube fitting, curved	6.4 - 8 mm ID	PTFE	1
C	160 142	Tube fitting, straight	6.4 - 8 mm ID	PTFE	1
D	107 811	Tube fitting, straight	2 - 3 mm ID	PP	1
E	107 812	Tube fitting, straight	3 - 4 mm ID	PP	1
F	107 813	Tube fitting, straight	4 - 6 mm ID	PP	1
G	107 814	Tube fitting, straight	5 - 7 mm ID	PP	1
H	107 816	Tube fitting, straight	6.2 - 7.5 mm ID	PP	1
I	107 817	Tube fitting, straight	9.5 - 11 mm ID	PP	1
J	107 808	Tube fitting, angled	6.4 - 8 mm ID	PP	1
K	107 810	Tube fitting, angled	9.5 - 10 mm ID	PP	1

ACCESSORIES

Accessories

Adapter for the tube connector



Flexible like no other!
The tube connector
 Our adapters offer numerous possibilities:

L 160 141



M 160 132



N 160 137



O 160 129



P 160 131



Q 160 130



R 160 128



S 117 819



T 117 821



Fig.	Part No.	Description	For tube diameter		Material	Unit
-	160 506	Blind plug for tube connector	-		PTFE	1
L	160 141	2-in-1 collector	2.3 / 3.2 mm OD		PTFE / PFA	1
-	160 144	2-in-1 collector	2.3 / 3.2 mm OD		PTFE	1
M	160 132	3-in-1 collector	2.3 / 3.2 mm OD		PTFE / PFA	1
N	160 137	8-in-1 collector	2.3 mm OD		PTFE / PFA	1
O	160 129	8-in-1 collector	2.3 mm OD (7x)	6.4 mm ID (1x)	PTFE / PFA / PP	1
P	160 131	3-in-1 collector, angled	2.3 / 3.2 mm OD		PTFE / PFA / PP	1
Q	160 130	3-in-1 collector, angled	2.3 / 3.2 mm OD (2x)	6.4 mm ID (1x)	PTFE / PFA / PP	1
R	160 128	3-in-1 collector, straight	6.4 mm ID (3x)		PTFE / PP	1
S	117 819	Tube fitting, straight, + sealing nut	8 mm ID		PTFE	1
T	117 821	Tube fitting, straight, + sealing nut	6.5 mm ID		PTFE	1

Accessories

Special adapters for further systems

A 199 010



3-way adapter for T-piece

The adapter locks the open T-piece of the HPLC system gastight and avoids the leakage of harmful vapors. Adapter, tube-piece and 3x Fittings for capillaries with \varnothing 1.6 mm outer diameter are included in the scope of delivery.

Fig. **Part No.** **Description**

A 199 010 3-way adapter for T-piece incl. tube-piece and 3x Fittings for capillaries with \varnothing 1.6 mm outer diameter

S.C.A.T. waste systems now also fit your containers of JUSTRITE®.

Proven S.C.A.T. Europe safety at Justrite® containers. Suitable adapters for CPC®- couplings.

B 107 628





C 107 617



D 107 610



Fig. **Part No.**

							
			Capillary connector 3.2 / 2.3 mm OD	Tube connector 6.4 mm ID	Connector for exhaust filter	Material	Unit
B	107 628	4-way collector for CPC connector	3x	1x	-	PTFE / PFA / PP	1
C	107 617	Adapter S.C.A.T. exhaust filter to CPC-coupling	-	-	1x	PE-HD	1
D	107 610	Adapter S.C.A.T. exhaust filter to stainless steel coupling	-	-	1x	PE-HD	1

Access to containers during operation

Direct access to your containers

With this adapter, connecting each ND9 short thread cap of your sample bottles with the S.C.A.T. safety system is easy. This way you have access to the contents of your **supply and waste containers** even during ongoing operations, without evaporation or contamination.

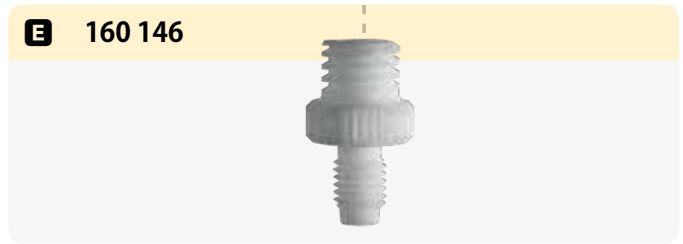
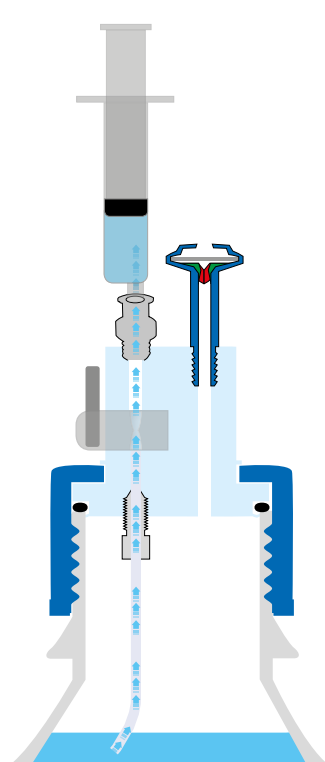

Fig.	Part No.	Description	Material	Unit
E	160 146	Adapter for septum caps with short thread ND9	PTFE	1



Luer adapter

The illustration shows solvent extraction out of a dispensing bottle which is closed through a SafetyCap with shut-off.

Fig.	Part No.	Description	Material	Unit
F	160 191	Luer adapter for the capillary connector	PP	1

Accessories

Tube connectors



Images A - L shown on a scale of 1:1.

Just add the tube and identify the size easily.



A 107 802



B 107 803



C 107 804



D 107 806



E 107 807



F 107 825



G 107 824



H 107 823



I 107 822



J 107 821



K 107 820

L 107 826



Fig.	Part No.	Description	Diameter		Material	Unit
-	107 801	Y-connector	3 mm		PP	1
A	107 802	Y-connector	4 mm		PP	1
B	107 803	Y-connector	5 mm		PP	1
C	107 804	Y-connector	6 mm		PP	1
D	107 806	Y-connector	9 mm		PP	1
E	107 807	Y-connector	11 mm		PP	1
F	107 825	Conical connector	3 - 5 mm	3 - 5 mm	PP	1
G	107 824	Conical connector	4 - 8 mm	4 - 8 mm	PP	1
H	107 823	Conical connector	7 - 10 mm	7 - 10 mm	PP	1
I	107 822	Conical connector	4 - 8 mm	8 - 12 mm	PP	1
J	107 821	Conical connector	4 - 8 mm	12 - 16 mm	PP	1
K	107 820	Conical connector	8 - 12 mm	12 - 16 mm	PP	1
L	107 826	Connector, spherical	5 - 16 mm	7.5 - 16 mm	PP	1

CPC couplings, capillary connector



New improved system. With one „click“!

The quick disconnect couplings allow safe and quick connection of tubing and make bottle changes even easier. The bottles are rapidly disconnected with a single "click" and can be refilled at a safe location.

Thanks to the integrated valve function, the closed safety system is maintained even when a tube is disconnected.

The practical CPC quick disconnect couplings can be used for all S.C.A.T. safety systems.

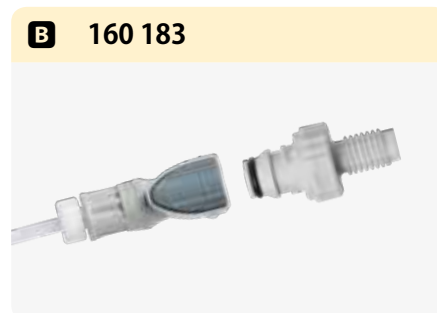

Fig.	Part No.	Description	Capillary diameter	Material	Unit
A	160 189	Valve coupling unit set, incl. 2x 1.5 m capillary	3.2 mm OD, corresponds to 160 179 plus 160 190	PP	1
B	160 183	Valve coupling unit set, incl. 2x 1.5 m capillary	3.2 mm OD, corresponds to 160 179 plus 160 180	PP	1
C	160 179	Valve coupling unit (f), incl. 1x 1.5 m capillary	3.2 mm OD, can be used with 160 190 and 160 180	PP	1
D	160 190	Valve coupling unit (m), incl. 1x 1.5 m capillary	3.2 mm OD, can be used with 160 179	PP	1
E	160 180	Valve coupling unit (m), for capillaries	3.2 mm AD for screwing in standard connector, can be used with 160 179	PP	1
F	160 145	Capillary connector for standard capillaries with each 2x Fittings for 1.6 / 2.3 / 3.2 mm OD	1.6 / 2.3 / 3.2mm OD	PTFE	1



Accessories Thread adapters

**If it doesn't fit -
we'll make it fit.**

Our numerous thread adapters are well-proven assistants through the daily working routine in laboratory and production.

Type **A**

internal thread (f)

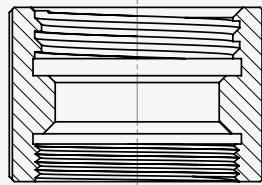
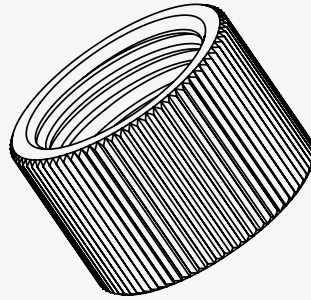

Type **B**

external thread (m)

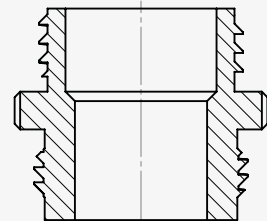
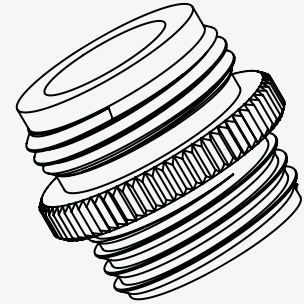

Type	Part No.	Thread 1	Thread 2	Material	Color
A	107 024	S 55 (f)	R 2" fine (f)	PP	Green
A	107 082	S 60/61 (f)	2" Tri-Sure (f)	PE-HD-ec	Black
A	107 023	S 60/61 (f)	R 2" fine (f)	PP	Yellow
A	108 444	63 mm ASTM (f)	R 2" fine (f)	PP	White
A	107 025	S 70/71 (f)	R 2" fine (f)	PP	Brown
Type	Part No.	Thread 1	Thread 2	Material	Color
B	107 014	GL 45 (m)	R 2" BSP (m)	PP	Colorless
B	107 016	GL 45 (m)	R 2" BSP (m)	PTFE	White
B	107 015	GL 45 (m)	2" Tri-Sure (m)	PP	Colorless
B	107 017	GL 45 (m)	2" Tri-Sure (m)	PTFE	White
B	108 022	S 60/61 (m)	2" BSP (m)	PP	Black
B	108 029	S 60/61 (m)	2" Tri-Sure (m)	PP	Colorless
B	107 087	S 60/61 (m)	63 mm ASTM (m)	PP	Colorless
B	107 098	S 70/71 (m)	S 70/71 (m)	PTFE	White

ACCESSORIES





Type **C**

internal/external thread (f/m)

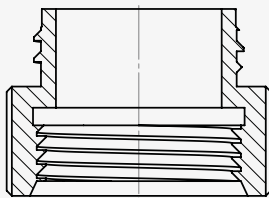
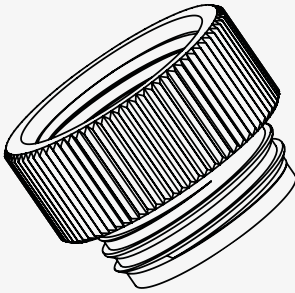

C 108 058

The angled-adapter for canisters.

Just place your laboratory bottles on the funnel-sieve and let them drip of easily.



Type	Part No.	Thread 1	Thread 2	Material	Color
C	108 060	S 40 (m)	GL 45 (f)	PTFE	White
C	107 996	GL 45 (m)	GL 32 (f)	PP	Colorless
C	107 993	GL 45 (m)	GL 32 (f)	PTFE	White
C	107 995	GL 45 (m)	GL 38 (f)	PP	Colorless
C	107 992	GL 45 (m)	GL 38 (f)	PTFE	White
C	107 994	GL 45 (m)	S40 / GL 40 (f)	PP	Colorless
C	107 991	GL 45 (m)	S40 / GL 40 (f)	PTFE	White
C	107 093	GL 45 (m)	S 51 (f)	PP	Colorless
C	107 099	GL 45 (m)	S 55 (f)	PP	Colorless
C	107 090	GL 45 (m)	S 60/61 (f)	PP	Colorless
C	107 079	GL 45 (m)	S 70/71 (f)	PP	Colorless
C	117 030	GL 45 (m)	GPI 38-23 (f)	PTFE	White
C	107 028	GL 45 (m)	R 1 1/2" (f)	PP	Colorless
C	107 080	S 51 (m)	S 47 x 4 (f)	PP	Colorless
C	107 092	S 51 (m)	S 55 (f)	PP	Colorless
C	107 086	S 51 (m)	S 60/61 (f)	PP	Colorless
C	107 078	S 55 (m)	S40 / GL 40 (f)	PP	Colorless
C	117 091	S 55 (m)	S40 / GL 40 (f)	PTFE	White
C	107 084	S 55 (m)	S 50 (f)	PP	Colorless
C	107 095	S 55 (m)	S 51 (f)	PP	Colorless
C	117 095	S 55 (m)	S 51 (f)	PTFE	White
C	107 094	S 55 (m)	GL 45 (f)	PP	Colorless
C	117 094	S 55 (m)	GL 45 (f)	PTFE	White
C	107 089	S 55 (m)	S 60/61 (f)	PP	Colorless
C	107 076	S 55 (m)	Sakura Tissue Tek (f)	PP	Colorless
C	108 058	S 60/61 (m) angled	S 60/61 (f)	PE-HD-ec	Black
C	108 145	S 60/61 (m)	S 50 (f)	PE-HD-ec	Black
C	107 097	S 60/61 (m)	S 51 (f)	PP	Colorless
C	108 146	S 60/61 (m)	S 51 (f)	PE-HD-ec	Black
C	107 096	S 60/61 (m)	S 55 (f)	PP	Colorless
C	108 021	S 60/61 (m)	2" BSP (f)	PP	Grey
C	107 091	S 60/61 (m)	B 63 (f)	PP	Colorless
C	107 074	S 60/61 (m)	S 65 (f)	PP	Colorless
C	107 026	S 60/61 (m)	R 3" Schütz coarse (f)	PP	Grey
C	107 027	S 60/61 (m)	R 3" Werit fine (f)	PP	Colorless
C	107 088	S 65 (m)	63 mm ASTM (f)	PP	Colorless
C	108 147	S 60/61 (m)	S 71 (f)	PE-HD-ec	Black
C	107 083	S 70/71 (m)	Mason thread 70 (f)	PP	Colorless
C	107 018	S 90 (m)	S 100 / BB 70 (f)/VIR	PE-HD	Colorless
C	107 085	R 1 1/2" (m)	GL 45 (f)	PP	Colorless
C	107 021	2" Mauser coarse (m)	R 2" fine (f)	PP	Blue
C	107 022	2" Tri-Sure coarse (m)	R 2" fine (f)	PP	Orange



Accessories

Ground cables



Fig.	Part No.	Description	Included	Length
A	108 009	Ground cable	2 clamps	1.5 m
B	108 011	Ground cable	1 clamp, 1 connection ring (Ø 10 mm)	1.5 m
C	117 982	Ground cable	1 clamp, 1 connection ring (Ø 5 mm)	1.5 m
D	107 938	Ground cable	1 clamp, 1 plug for SafetyWasteCap ground connection	1.5 m
E	108 275	Ground cable	1 press stud connector, 1 connection ring (Ø 5 mm)	1.5 m
-	108 272	Ground cable	1 mc connector, 1 connection ring (Ø 5 mm)	1.5 m
F	108 176	Ground cable	1 clamp, 1 ground clip for Ø 32 mm pipe, suitable for SymLine pipe system, incl. mounting material	3.0 m

Fig.	Part No.	Description	Unit
G	117 995	Grounding cable splitter made from brass with 1 outgoing line, 5 input ports, without cables. Mounting material is included in the scope of delivery	1
H	108 092	Earthing plug for isolated ground receptacle, 1x press stud connector, 2x 10 mm connector	1
I	108 099	Anti-static mat, conductive. With ground cable (press stud connector). Dimensions: 610 x 1220 mm	1
J	108 096	Ground strap for canisters with S90 thread, incl. ground cable with clamp. Material: Stainless steel	1



Safety at one click, with the ONLINE- CONFIGURATOR.

Our grounding cable splitter arranges a clear cable-management. The 5 input ports and the collective outgoing line can be equipped in any way. Just choose your favored cable type, define the length - done! We deliver your favored configuration.

Configure your cabling easily with just a few clicks. The grounding cable splitter will be delivered with assembled cables. Mounting material is included in the scope of delivery.

www.scat-europe.com/GROUNDING



Accessories

Tubes and capillaries

A 108 015

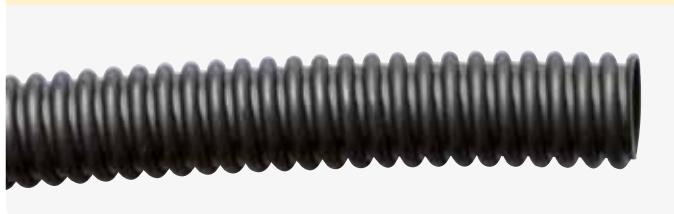

B 108 018



C 108 017



D 108 016



Fig.	Part No.	Description	Diameter	Length
A	108 015	Conductive plastic tube, flexible (spiral)	9 mm ID, 13 mm OD	1 m
-	108 019	Conductive plastic tube, smooth	10 mm ID, 12 mm OD	1 m
B	108 018	Conductive plastic tube, smooth	8 mm ID, 10 mm OD	1 m
C	108 017	Conductive plastic tube, smooth	6 mm ID, 8 mm OD	1 m
D	108 016	Conductive plastic tube, smooth	4 mm ID, 6 mm OD	1 m

E 461 056



F 461 055



G 461 054



H 461 053



Fig.	Part No.	Description	Unit
E	461 056	Corrugated tube, PP, for leak connection of various HPLC systems, \varnothing ID = 6.5 mm	1 m
F	461 055	Capillary PTFE, \varnothing OD = 3.2 mm, \varnothing ID = 1.6 mm	3 m
G	461 054	Capillary PTFE, \varnothing OD = 2.3 mm, \varnothing ID = 1.7 mm	3 m
H	461 053	Capillary PTFE, \varnothing OD = 1.6 mm, \varnothing ID = 1.0 mm	3 m

Accessories

Suction filters and tools



Fig.	Part No.	Description	Unit
I	300 021	Suction filter HPLC solvent filter UHMW-PE, for \varnothing 1/8" (\varnothing 3.2 mm OD) pore size 20 μ m	5 each
-	300 022	Suction filter HPLC solvent filter PFA/PTFE, for \varnothing 1/8" (\varnothing 3.2 mm OD) pore size 5 μ m	5 each

Tools

Installation wrench for fittings and capillary cutter incl. replacement blade.

Fittings and capillaries are not included in the scope of delivery.



Fig.	Part No.	Description	Form	Material	Color
B	160 500	Installation wrench, hexagonal (for PFA fittings)		Aluminium	Aluminium
C	160 499	Installation wrench, square (for PP fittings, e.g. older versions of SafetyCaps)		PP	Black
D	900 103	CleanCut capillary cutter including replacement blade	-	PP, stainless steel	Blue

CHECKMATE FOR HAZARDOUS LIQUIDS!

Keep waste liquids which are hazardous to health and environment in check, before they become dangerous for you. This is the SymLine[®] principle.



What is SymLine[®]? The right strategy for liquid waste!

Environmental protection, more free space, less hazards at your workplace - the SymLine[®] system integrates directly into your laboratory furniture. Waste containers are stored outside your working space. For more safety, comfort and sustainable pollution control.

Perfectly synchronised.

Perfectly synchronised parts and devices make handling of waste liquids as safe as never before. Whether in laboratories, technical centres or production plants - SymLine[®] has the right components for sustainable liquid waste management.



SymLine® is a brand of



Economical and efficient.

The disposal containers can be used at the same time by several work stations. Splashes and spilt hazardous material are things of the past.

No disturbances or interruptions!

Dispose of your liquids directly at the experiment setting without long routes to the collection containers. This saves time and your filling level is continuously monitored.

Holistic and sustainable.

SymLine® provides a fully complete disposal concept. The modular system provides many individual combination options and it is simple to integrate external units.

Ideal accessibility.

Ideal access to the collection containers is also ensured in confined spaces – the tube system and numerous adapters have been specially developed for this purpose.

Efficient use of space.

The compact-space saving construction means that SymLine® components can be incorporated ideally into the concept of modern lab facilities – where it's a matter of economical use of working space available.

Safe for the environment and for health.

Daily liquid waste in the lab is transferred safely and in line with regulations between the working and storage area – without any emission in the working environment harmful to health or the environment.



www.symline.de

SymLine[®]

Chemical Waste Systems

ACTIVE DISPOSAL: IN LINE WITH REGULATIONS!

'Active storage is the storage of flammable liquids in (...) transportable, non-breakable containers, which are used in their storage place as stationary removal or collection containers or are opened for other purposes.'

(Extract TRbF 20, updated version: TRGS 510)

SymLine[®] not only provides active storage but incorporates the entire lab into its safety concept. From the collective point at withdrawal to storage in the collecting container. This ensures that **active disposal** results from active storage.

HPLC connection

Connection of waste tubes with solvent waste – directly into the disposal system!



Safety Funnel & Sink

Disposal is made directly on drainage – no long routes to the waste receptacles.

FUME CUPBOARD

Pipe and tube system

Numerous connection options for ideal adjustment to your workplace. Individual tube lengths and adapters ensure maximum flexibility.

Grounding and Antistatic

Electrostatic conductive plastics ensure ideal protection against static charging and spark formation.

Safety Cabinets

Explosion and fire prevention in accordance with the latest standards.

Containers & Caps

Gases and vapours do not penetrate the lab air. Exhaust filters and ventilation lines effectively eliminate risks for health and environment.

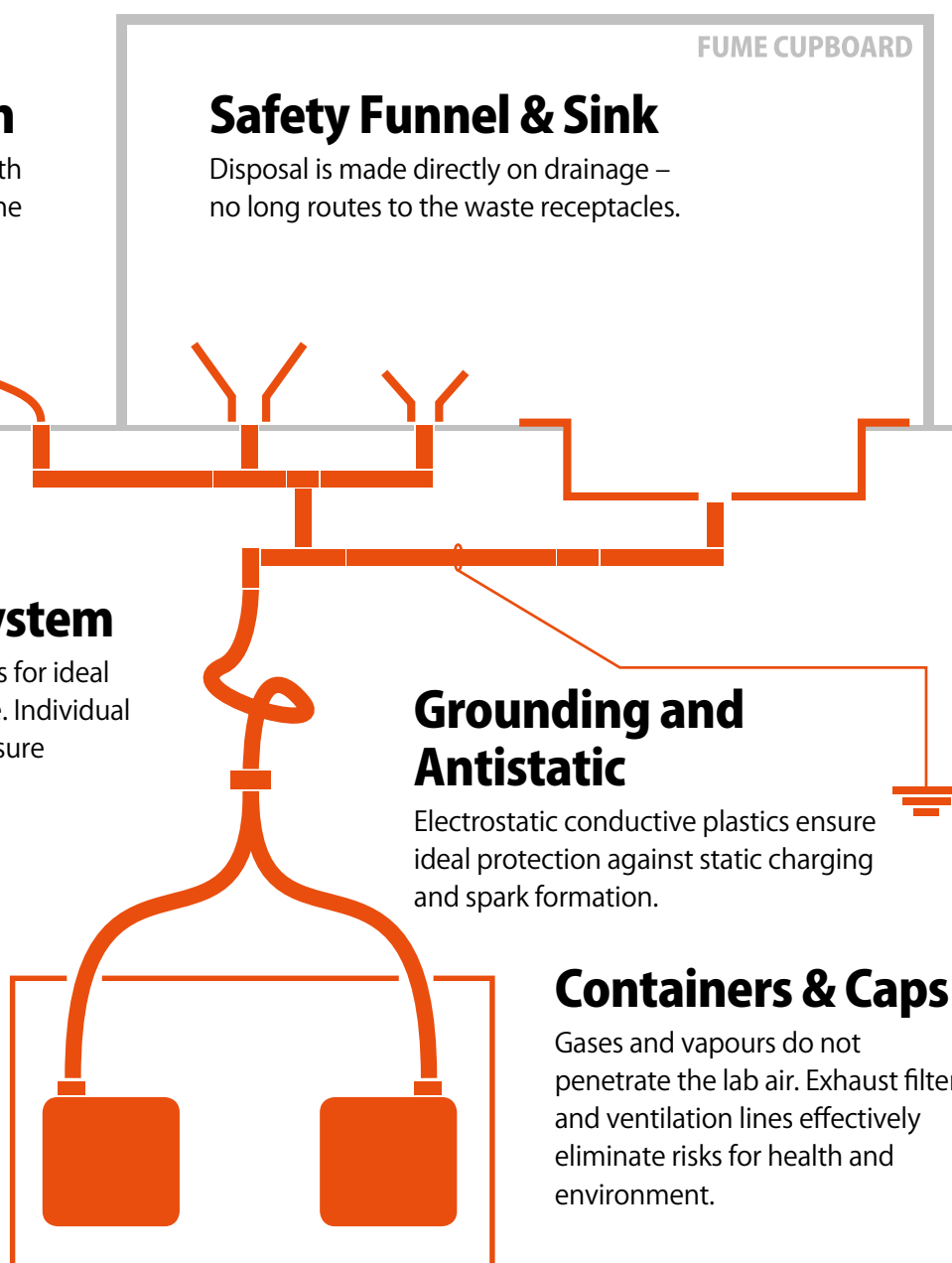

SymLine® is a brand of



CLEVER & SAFE DISPOSAL.

SymLine® is included in design planning by leading lab furniture manufacturers in the planning phase for new laboratory buildings. Our modular and flexible system can also be incorporated easily into existing lab facilities.



YOU'RE PLANNING SOMETHING? WE CAN HELP!

Talk to your lab furniture manufacturer, lab planner and to us about SymLine® products.

www.symlines.de

Thread Types Determination



Drawings in scale 1:1

NPT (National Pipe Thread) tapered, american pipe thread

Easy recognisable by its tapered outer and inner diameter which is selfsealing.

Therefore, NPT threads are also known as "sealing thread" or "tightly threaded connection".

NPT 1/8" – outer- \varnothing = 9.9 mm

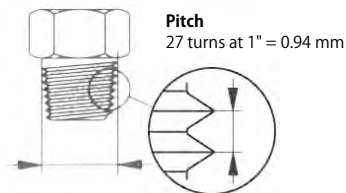

NPT 1/4" – outer- \varnothing = 13.2 mm

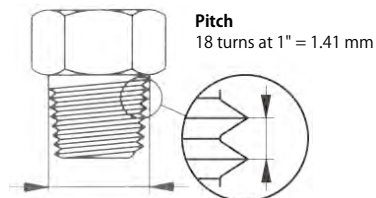

NPT 3/8" – outer- \varnothing = 16.6 mm

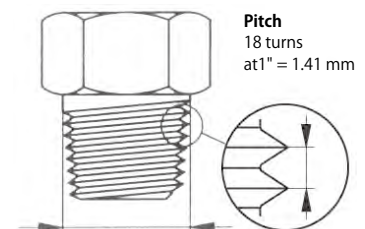

NPT 1/2" – outer- \varnothing = 20.6 mm

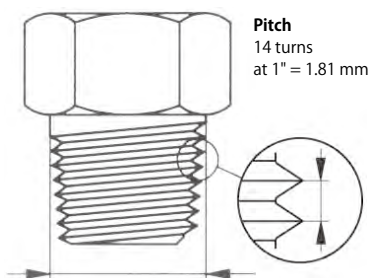

NPT 3/4" – outer- \varnothing = 26 mm

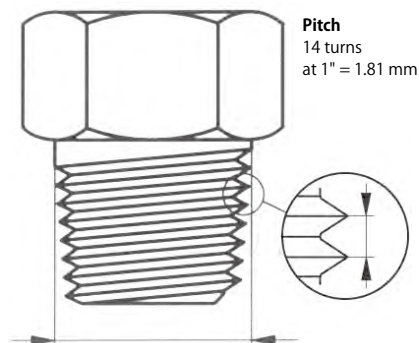

NPT 1" – outer- \varnothing = 32.5 mm

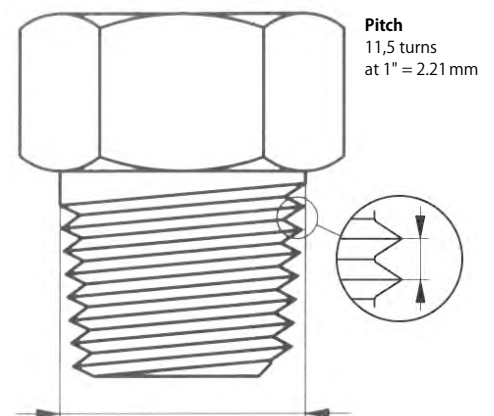



Drawings in scale 1:1

G or R (Whitworth thread) and BSP (British Standard Pipe)

Cylindrical threads which are mainly used in countries with imperial system. The size of e.g. R 3/4" does not stand for a diameter. Thus the corresponding size has to be determined according to charts.

G 1/8" – outer- \varnothing = 9.6 mm

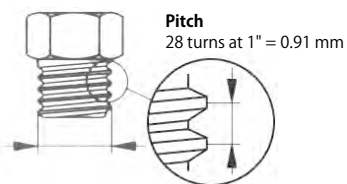

G 1/4" – outer- \varnothing = 13 mm

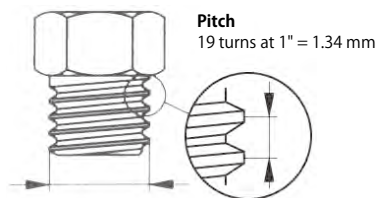

G 3/8" – outer- \varnothing = 16.5 mm

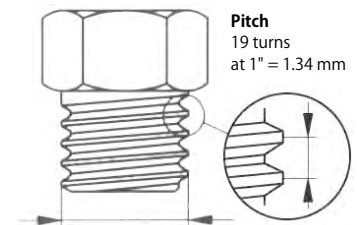

G 1/2" – outer- \varnothing = 20.8 mm

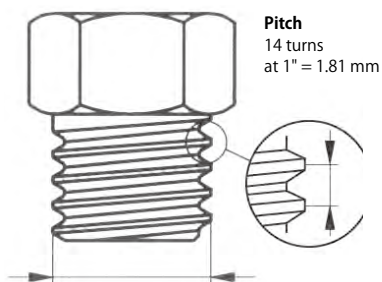

G 5/8" – outer- \varnothing = 22.8 mm

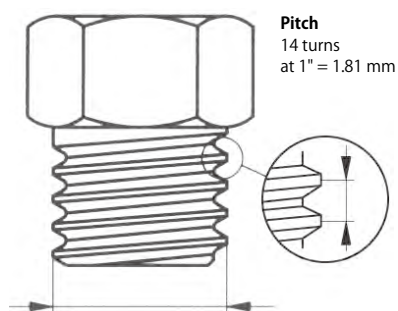

G 3/4" – outer- \varnothing = 26.3 mm

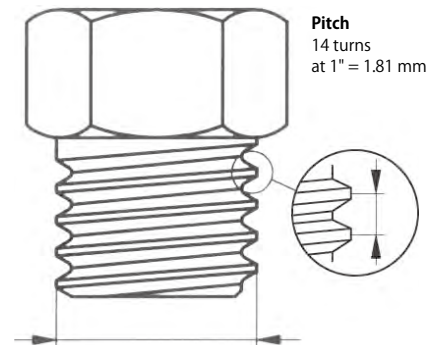

Thread Types Determination



Drawings in scale 1:1

M (metric ISO-thread) – standard in Europe

Cylindrical inner and outer diameter which is precise in millimetres. The extremely fine taper of this thread allows the best possible force transmission. Metric threads are designated by a capital M plus an indication of their nominal outer diameter, for instance M 10. A taper deviating from the standard is marked with an appendix like for instance M 10 x 0.75.

M5 – outer- \varnothing = 5 mm

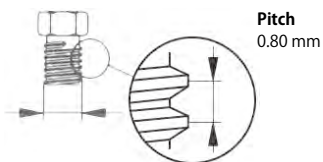

M6 – outer- \varnothing = 6 mm

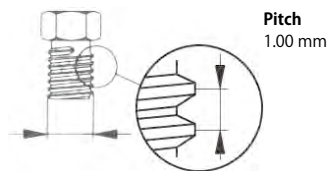

M8 – outer- \varnothing = 8 mm

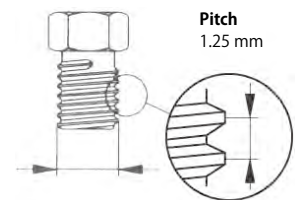

M10 – outer- \varnothing = 10 mm

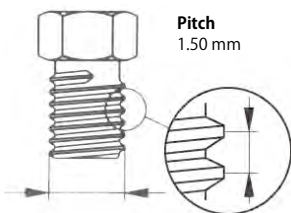

M12 – outer- \varnothing = 12 mm

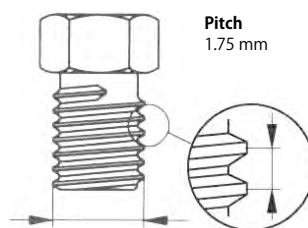

M16 – outer- \varnothing = 16 mm

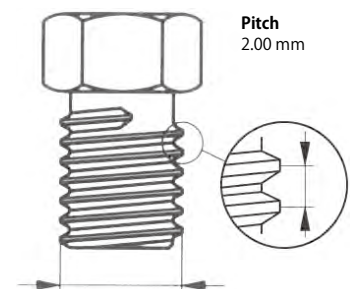



Drawings in scale 1:1

UNF 1/4"-28G

It has its origin in the USA. Mainly used in chromatography/HPLC applications. Most common sizes are UNF 1/4"-28G and UNF 10-32G. The digits 28 G and 32 G stand for the number of thread pitches at a length of one inch (25.4 mm).

UNF 1/4"-28G versus M6

Without exception all of our HPLC fittings come with the most common HPLC thread UNF 1/4"-28G. In addition, fittings and distributors with the very similar thread M 6 are used. These threads can only be distinguished by exact determination of their outer diameter or by using a test mandrel (it is possible to screw in a tube end fitting in the counterpart of the other thread for at least 2-3 rotations). The UNF 1/4" thread has an outer diameter of 6.35 mm, the M 6 thread has precisely 6 mm (work tolerances are possible). We recommend to use only the UNF 1/4"-28G thread to avoid confusion and double inventory.

UNF 1/4"-28G – outer- \varnothing = 6.2 mm

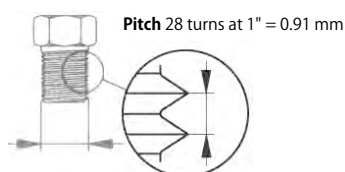

UNF 3/8"-28G – outer- \varnothing = 9.4 mm

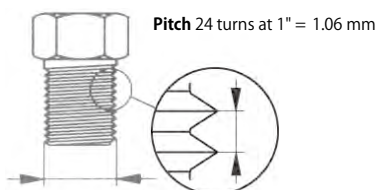

UNF 1/2"-28G – outer- \varnothing = 12.6 mm

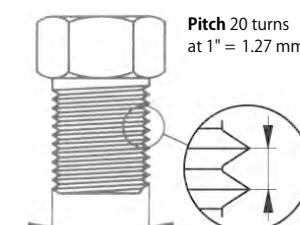

UNF 5/8"-18G – outer- \varnothing = 15.7 mm

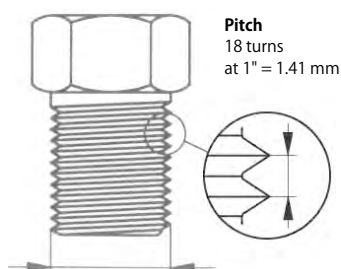

UNF 3/4"-16G – outer- \varnothing = 18.9 mm

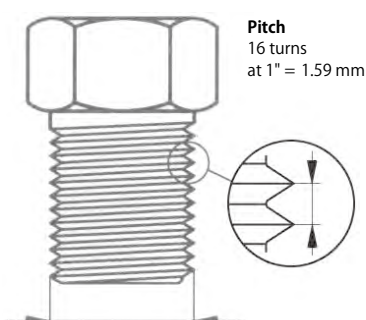

UNF 1"-12G – outer- \varnothing = 25.2 mm

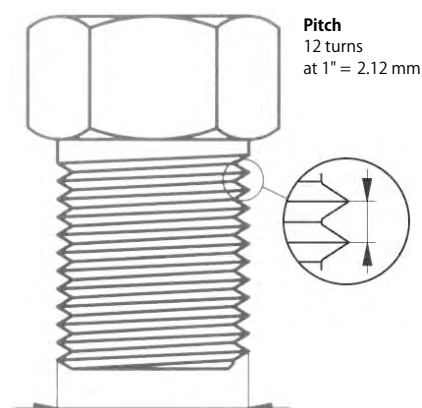

Thread Types Canisters

Drawings in scale 1:1

Threads S 55 and S 60

All thread types for canisters are listed in the chapter of waste systems.

S 55 – outer- \varnothing = 53.5 mm

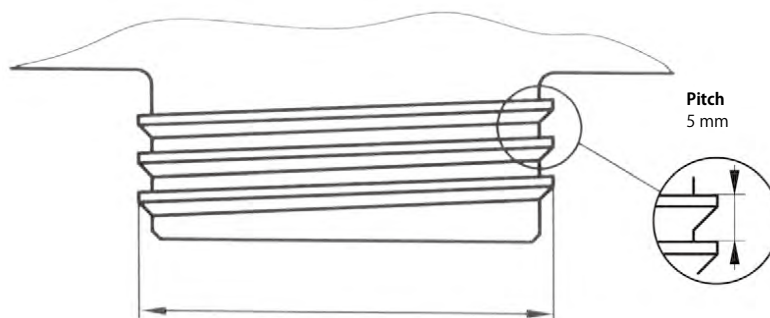

S 60 – outer- \varnothing = 59.5 mm

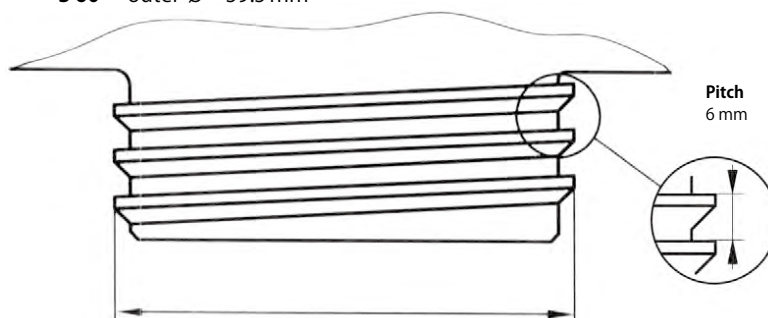

Drawings in scale 1:1

BCS 70x6 MAUSER 2"®

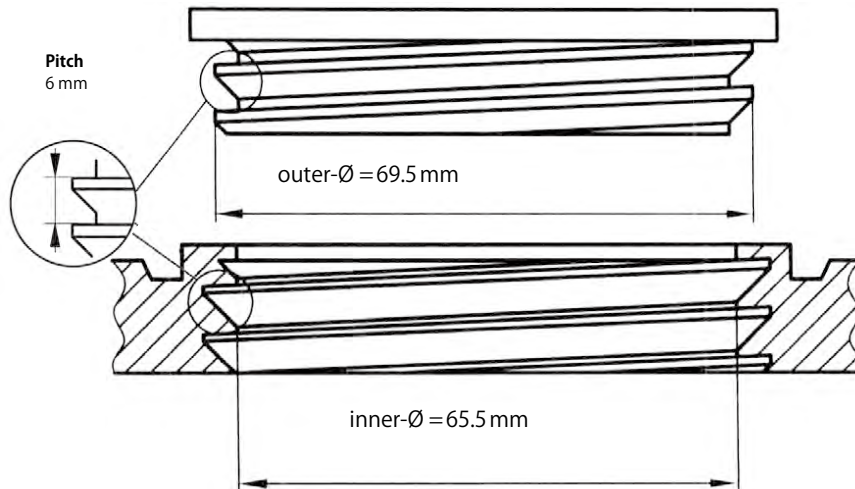

G2"/R 2"/BSP 2"

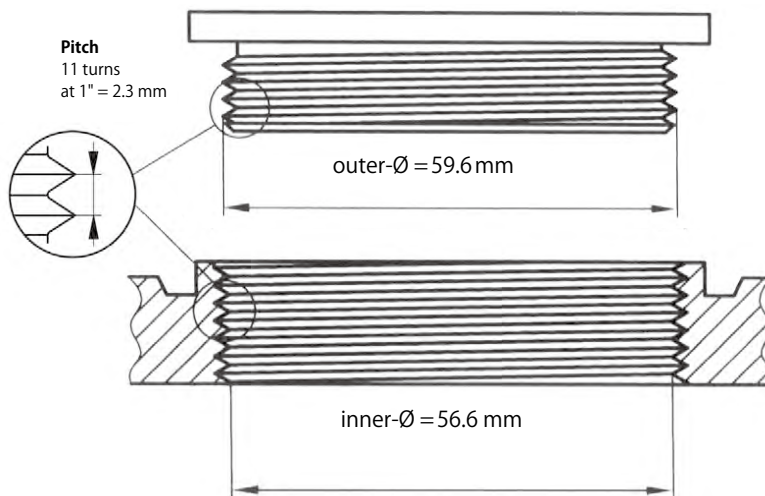

BCS 56x4 Tri Sure2"®

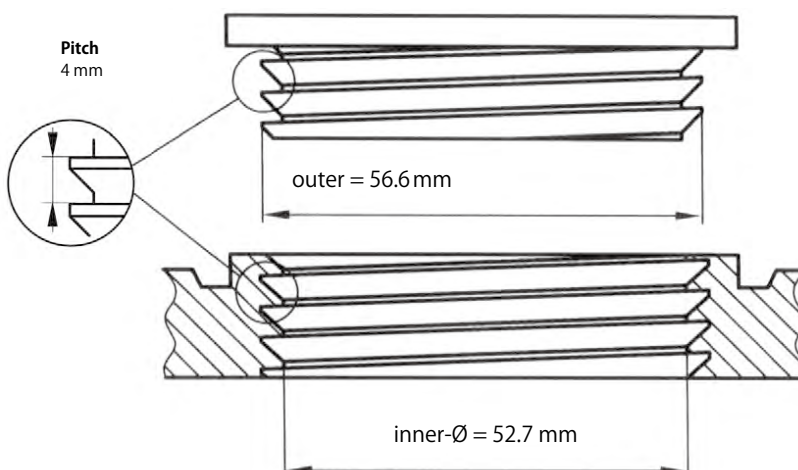

Thread Types

Glas threads

Drawings in scale 1:1

GL-threads

GL threads are round threads, i.e. there are only round and no sharp ends at the flanks of the screw thread. Due to its simple shape and the round ends of the flanks, this thread can easily be formed on glass pipes. The extremely high pitch and the large flanks give this thread an important carrying power.

GL 12 – outer- \varnothing = 12 mm

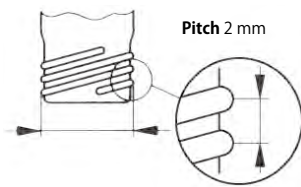

GL 14 – outer- \varnothing = 14 mm

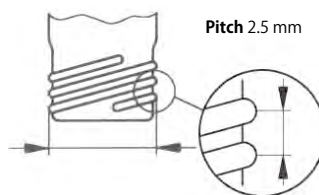

GL 18 – outer- \varnothing = 18 mm

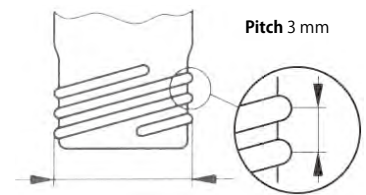

GL 25 – outer- \varnothing = 25 mm

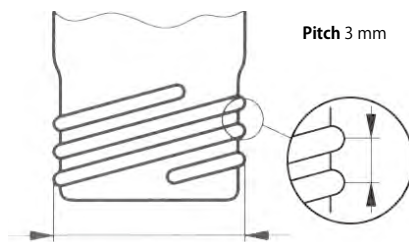

GL 32 – outer- \varnothing = 32 mm

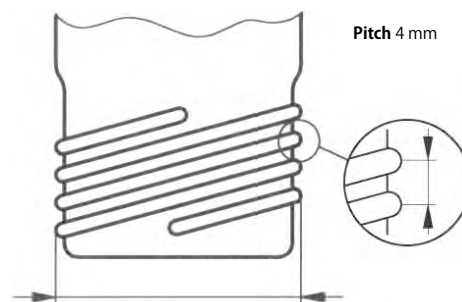

GL 45 – outer- \varnothing = 45 mm

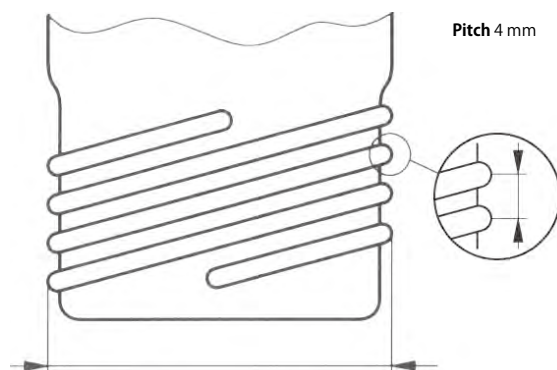

Drawings in scale 1:1

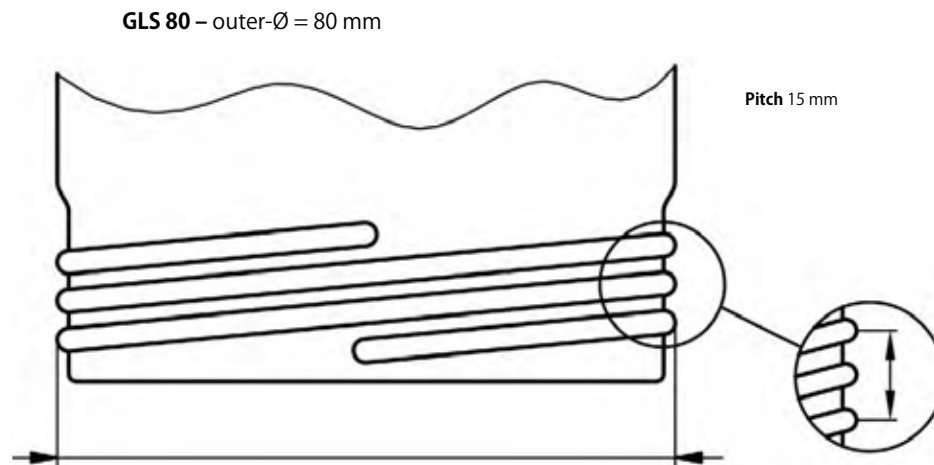

Conversions Inches - Millimeters / Millimeters - Inches

Inches in Millimeters		
Inch Fractional notation "	Inch Decimal notation "	Millimeters Decimal notation mm
1/16	0.062	1.57
1/8	0.125	3.18
3/16	0.188	4.78
1/4	0.250	6.35
5/16	0.313	7.95
3/8	0.375	9.53
7/16	0.438	11.13
1/2	0.500	12.70
9/16	0.563	14.30
5/8	0.625	15.88
11/16	0.688	17.48
3/4	0.750	19.05
13/16	0.813	20.65
7/8	0.875	22.23
15/16	0.938	23.83
1	1	25.40
2	2	50.80
3	3	76.20
4	4	101.60
5	5	127.00
6	6	152.40
7	7	177.80
10	10	254.00

Millimeters to Inches	
Millimeters mm	Decimal Inches in "
1.0	0.039
1.8	0.071
2.0	0.079
3.0	0.118
3.2	0.126
4.0	0.157
4.3	0.169
4.6	0.181
5.0	0.197
6.0	0.236
7.0	0.276
8.0	0.315
9.0	0.354
10.0	0.394
20.0	0.787
30.0	1.181
40.0	1.575
50.0	1.969
60.0	2.362
70.0	2.756
80.0	3.150
90.0	3.543
100.0	3.937

Part Number Index

Part No.	Pages	Part No.	Pages	Part No.	Pages	Part No.	Pages
100 703	86	107 074	114	107 303	16	107 712	95, 96
101 994	90	107 076	114	107 304	16	107 713	95, 96
101 995	90	107 078	114	107 307	61	107 720	94
101 996	90	107 079	114	107 310	61	107 721	94
101 997	90	107 080	114	107 312	15	107 722	94
101 998	90	107 082	113	107 313	16	107 730	96
107 000	81	107 083	114	107 314	16	107 731	94
107 005	13	107 084	114	107 315	72	107 733	96
107 006	13	107 085	114	107 319	10	107 740	96
107 007	7	107 086	114	107 320	72	107 740	83
107 008	7	107 087	113	107 321	72	107 742	14
107 009	7	107 088	114	107 328	61	107 801	111
107 014	113	107 089	114	107 330	97	107 802	111
107 015	113	107 090	114	107 331	97	107 803	111
107 016	113	107 091	114	107 332	97	107 804	111
107 017	113	107 092	114	107 333	97	107 806	111
107 018	114	107 093	114	107 334	97	107 807	111
107 019	5, 18	107 094	114	107 335	97	107 808	107
107 021	114	107 095	114	107 336	97	107 810	20
107 022	114	107 096	114	107 337	19	107 810	107
107 023	113	107 097	114	107 338	97	107 811	107
107 024	113	107 098	113	107 339	97	107 812	107
107 025	113	107 099	114	107 345	15	107 813	107
107 026	114	107 100	13	107 346	16	107 814	107
107 027	114	107 101	13	107 347	16	107 816	107
107 028	114	107 105	13	107 348	16	107 817	107
107 030	14	107 108	35	107 349	16	107 820	111
107 031	14	107 109	35	107 353	16	107 821	111
107 032	14	107 119	9	107 354	16	107 822	111
107 034	53	107 219	10	107 362	16	107 823	111
107 035	14	107 241	40	107 363	15	107 824	111
107 036	53	107 242	40	107 410	6	107 825	111
107 037	41	107 243	40	107 416	71, 72	107 826	111
107 038	47	107 244	40	107 506	12	107 880	86
107 041	105	107 245	41	107 507	12	107 881	86
107 042	105	107 246	41	107 508	12	107 882	86
107 043	105	107 247	47	107 509	12	107 883	86
107 044	8, 106	107 248	47	107 512	14	107 884	86
107 045	8, 106	107 249	47	107 519	10	107 885	85
107 046	8, 106	107 250	48	107 520	6	107 886	85
107 047	8, 106	107 251	48	107 607	12	107 889	85
107 048	105	107 252	48	107 610	109	107 909	5, 18
107 050	47	107 253	48	107 617	109	107 910	5, 20
107 051	47	107 254	48	107 620	104	107 911	61
107 052	53	107 255	54	107 621	104	107 912	35
107 053	54	107 256	57	107 622	104	107 913	51
107 054	41	107 257	57	107 624	104	107 915	51
107 057	42	107 258	57	107 627	104	107 916	45
107 059	105	107 259	57	107 628	109	107 917	43
107 060	105	107 260	57	107 632	104	107 918	45
107 061	20, 105	107 261	58	107 704	94	107 919	9
107 062	20, 105	107 262	58	107 706	95, 96	107 920	9
107 063	20, 105	107 263	58	107 707	96	107 922	39
107 064	8, 20, 105	107 264	58	107 709	94	107 923	35, 61
107 065	20, 105	107 265	58	107 710	95, 96	107 924	43
107 066	105	107 300	15	107 711	91, 92	107 925	45

Part No.	Pages	Part No.	Pages	Part No.	Pages	Part No.	Pages
107 926	51	108 022	113	108 155	54	112 312	21
107 927	55	108 023	37	108 156	53	112 319	22
107 928	55	108 024	37	108 157	79	112 410	21
107 930	39	108 025	37, 61	108 158	79	112 419	22
107 933	92	108 026	37	108 159	79	112 519	22
107 935	40	108 027	93, 94	108 160	79	112 520	21
107 936	43	108 029	113	108 161	79	112 909	18, 21
107 938	115	108 030	44	108 176	115	112 910	21
107 939	115	108 031	56	108 192	93, 94	112 911	59, 103
107 940	95, 96	108 032	8	108 193	94	112 912	36
107 942	39	108 033	44	108 200	43	112 914	59, 103
107 943	44	108 034	45	108 201	44	112 919	22
107 944	46	108 035	51	108 202	50	112 920	22
107 945	52	108 037	80	108 203	49	112 921	35
107 947	55	108 038	80	108 204	54	112 923	36
107 949	56	108 042	72, 83, 84, 93, 94	108 205	53	117 010	6, 10, 11, 12, 20, 101
107 950	91, 92	108 043	72, 83, 84, 93, 94	108 214	93, 94	117 011	8, 101
107 951	20, 61, 91, 92	108 045	80	108 215	93, 94	117 030	114
107 952	61, 91, 92	108 046	49	108 216	93, 94	117 091	114
107 953	72, 93, 94	108 047	49	108 217	93, 94	117 094	114
107 955	92	108 048	80	108 230	56	117 095	114
107 956	93, 94	108 050	80	108 231	55	117 620	68
107 957	91, 92	108 051	80	108 272	115	117 621	67, 68, 72
107 958	91, 92	108 054	49	108 275	115	117 623	68
107 959	94	108 055	50	108 401	46	117 624	67, 68
107 960	43	108 058	114	108 402	46	117 625	67, 68
107 961	46	108 060	114	108 403	45	117 626	67, 68
107 962	52	108 087	77	108 404	46	117 629	67, 68
107 963	44	108 088	77	108 405	52	117 630	68
107 964	45	108 092	115, 116	108 406	52	117 631	68
107 965	51	108 096	115, 116	108 407	51	117 633	70
107 966	56	108 099	115, 116	108 408	52	117 634	70
107 967	55	108 115	94	108 420	83, 84, 96	117 639	68
107 968	50	108 119	77	108 421	83, 92	117 640	68
107 969	49	108 121	77	108 444	113	117 641	68
107 970	70	108 122	77	108 670	70	117 642	67, 68
107 986	59, 103	108 124	77	108 921	20, 35	117 643	68
107 991	114	108 125	79	108 945	83, 91, 92	117 644	67, 68
107 992	114	108 128	44	108 961	46	117 645	67, 68
107 993	114	108 129	46	108 964	46	117 649	67, 68
107 994	114	108 132	38	108 981	98	117 808	20, 107
107 995	114	108 133	50	108 985	60, 103	117 816	20, 106, 107
107 996	114	108 134	46	108 986	60, 103	117 819	108
107 998	61	108 135	50	108 987	60, 103	117 821	108
107 998	91, 92	108 136	52	109 032	7	117 982	67, 68, 69, 115
108 009	115	108 137	56	110 032	7	117 983	98
108 011	115	108 138	46	112 007	21	117 984	98
108 012	115	108 139	52	112 008	21	117 985	98
108 014	115	108 140	56	112 009	21	117 986	98
108 015	117	108 145	114	112 010	101	117 995	115, 116
108 016	117	108 146	114	112 019	18, 21	118 034	46
108 017	117	108 147	114	112 110	101	118 035	50
108 018	117	108 149	36	112 112	21	118 036	52
108 019	117	108 150	49	112 119	22	118 037	56
108 020	96	108 151	53	112 212	21	118 038	46
108 021	114	108 152	55	112 219	22	118 039	50

Part Number Index

Part No.	Pages	Part No.	Pages	Part No.	Pages	Part No.	Pages
118 040	52	160 128	108	300 021	118	610 499	97
118 041	56	160 129	108	300 022	118	610 500	97
118 140	36	160 130	108	461 053	117	610 501	97
118 141	38	160 131	108	461 054	117	610 502	97
118 142	42	160 132	108	461 055	117	610 503	97
118 143	44	160 134	105	461 056	117	610 504	97
118 144	46	160 137	108	501 110	89, 90	610 534	59, 102
118 145	50	160 141	108	501 112	89, 90	610 535	20, 59, 102
118 146	52	160 142	107	501 113	20, 89, 90	610 703	80
118 147	54	160 143	107	501 115	90	610 704	80
118 148	56	160 144	108	501 116	90	900 103	118
118 149	44	160 145	112	501 117	89, 90	900 107	80
118 150	46	160 146	110	501 118	89, 90	900 108	80
118 242	46	160 178	81	501 119	89, 90		
118 244	46	160 179	112	501 120	89, 90		
118 245	50	160 180	112	501 121	89, 90		
118 246	50	160 183	112	501 122	90		
118 247	52	160 189	112	501 125	90		
118 248	52	160 190	112	501 126	90		
118 249	56	160 191	110	501 127	90		
118 250	56	160 499	118	501 131	89, 90		
118 630	70	160 500	118	501 150	90		
118 950	69	160 501	6, 11, 18, 20, 105	501 151	90		
118 951	69	160 503	106	501 152	90		
118 952	69	160 506	108	501 156	90		
118 953	69	160 515	106	501 157	90		
118 954	69	160 555	70	501 158	90		
118 955	69	190 335	60, 102				
118 960	69, 72	190 336	60, 102				
118 961	69	197 010	6, 10, 101				
118 962	69	197 011	101				
118 964	69	197 050	101				
118 980	69	199 005	83				
118 981	69	199 010	109				
118 983	69	199 013	83, 84				
118 984	69	199 019	11				
118 985	69	199 200	18				
118 989	69	199 201	18				
118 990	69	199 210	18				
118 991	69	199 909	11				
118 992	69						
118 993	69						
118 994	69						
118 995	69						
118 999	69						

Keyword Index

Keyword	Pages
Accessories	99
Adapter	109 - 110, 113 - 114
Air valve	3 - 4, 99 - 100, 101
Angled adapter	66, 114
Antistatic	XVIII-XXIII
ATEX	78
Automatic closure	30
ball valve	81-82
Ball valve	65-68
Barrels	60, 85-86, 103
Base insert	98
Blind plug	6, 11, 105, 108
Built-in signal box	78
Cable	80
Canister	91-96
Capillaries	117
Capillary connection	29, 105-106
Capillary connector	112
Capillary cutter	118
Change advice label	3
Change indicator	28
Collecting Trays	71, 98
Collectors	108
Configurator	116
Container	87 - 98
Container thread	87 - 88
Conversion table	130
Corrugated tube	117
CPC couplings	112
Customized production	V
Disk sensor	75, 80
Disposal units	71 - 72
Economy pack	60, 101, 102
Electronic signal boxes	73-82
Electronic switchbox	81-82
Electrostatic conductive PE-HD	XVIII-XXIII
Electrostatic conductivity	XVIII-XXIII
Electrostatics	XVIII-XXIII
Exhaust filter	27, 59-60, 99-100, 102-104
Filling barrels	85
Fire protective material	21-24, 32, 59, 103
Fire-resistant material	21-24, 32, 59, 103
Fittings	105-106
Flat canister	47, 94
Floater	31, 91, 93, 75, 76, 83-86
Funnel	63-72
Funnel made of stainless steel	70
GHS dangerous substances directive	XXIV, 137
GHS symbols	XXIV, 137
Ground Neck Bottles	12, 90
Grounding cable	115-116
Grounding cable splitter	116
Grounding connection	32, 65-72, 98, 115-116
Grounding plug	116
Grounding strap	116
Hinged lid	66, 69-70

Keyword	Pages
HPLC sets	15-16, 19-20
HPLC starter kits	18
Installation wrench	118
Laboratory bottles	89-90
Laboratory furniture	119-122
Laboratory installation	119-122
laboratory planner	119-122
Level control	31, 73-86
Level control (electronic)	31, 75-82
Level control (mechanical)	31, 76
Low level control	79-80
Luer adapter	110
Mat	116
ND9 short thread adapter	110
Offset adapter for exhaust filter	104
Online configurator	116
Pictograms	XXVI-XXVII
Politainer	97
Preparative HPLC	7-8
Protective cage	84
Safety funnels	63-72
Safety lance	65, 67, 69
Safety storage cabinets	119-122
SafetyCaps	5-22
SafetyWasteCaps	35-58
Shut-off	9, 10, 30
Sieve	67 - 70
Signal boxes	77-82
Signal cable	80
Space-saving canister	37, 61, 91
Special adapter	109-110
Special sizes	13
Splash protector	59, 103, 65, 68
Spout	97
Stainless steel funnel	70
Stand for 2 space-saving canisters	92
Suction filter	118
Switch amplifier	77
Switchbox	81-82
SymLine	119-122
Test report	XIV-XVII
Thread adapter	85, 113-114
Thread info	35-58, 87-88, 123-130
Thread size	87-88
Tool	118
TRBS 2153	XXV
TRGS 526	XXV
TRGS 727	XXV
Tube connection	29, 33-34, 107-108
Tube connector	111
Tube fitting	107-108
Tubes	117
Ventilation adapter for funnel	70
Viewing stripe	92, 96, 83, 84
Wide neck bottles	90

Terms and Conditions of the S.C.A.T. Europe GmbH

§ 1 General

- 1.1 The following provisions apply to all initial, ongoing and future business relationships between us and our clients who are contractors/traders within the meaning of § 14 of the German Civil Code (Bürgerliches Gesetzbuch). Our Terms and Conditions of Supply, Performance and Payment apply exclusively and by placing orders with us our customers declare that they are in agreement with these conditions; this applies equally for future business if these conditions are expressly referred to or if they are not referred to but are sent to the customer in connection with an order that we are acknowledging. If the order is placed at variance with our Terms and Conditions of Supply, Performance and Payment, our Terms and Conditions of Supply, Performance and Payment apply even if we do not object to such alternative conditions. Terms and conditions which are at variance with our standard Terms and Conditions of Supply, Performance and Payment apply only if we have expressly acknowledged such alternative conditions in writing. Amendments of and additions to these Terms and Conditions of Business must be made in writing. The customer can only invoke collateral agreements prior to and at the conclusion of the contract if such agreements are confirmed in writing without delay. These provisions do not apply if our customer is a consumer within the meaning of § 13 of the German Civil Code. The language of our contractual dealings is German.
- 1.2 The customer's General Terms and Conditions of Business are excluded unless we have expressly recognized them.
- 1.3 Our offers are subject to final confirmation; we reserve the right to make technical changes to our products. Files that are important for conducting business may be stored by us on data processing equipment.
- 1.4 Supply contracts and all other agreements (including collateral agreements) as well as statements made by our representatives are only binding in law on us if confirmed in writing. Business correspondence printed on data processing equipment (e.g. order confirmations, invoices, credit notes, extracts from accounts, payment reminders) is binding in law without a signature.
- 1.5 We draw our customers' attention to the fact that we process and transmit their personal data (exclusively for business purposes) with the aid of electronic data processing equipment in accordance with the requirements of the German Federal Data Protection Act (Bundesdatenschutzgesetz).

§ 2 Agreement on prices

- 2.1 Our prices exclude any Value Added Tax which may be imposed by law and are ex works. In case of orders for which no prices are agreed, our prices valid on the day of delivery apply and are expressed in Euros (EUR) unless indicated otherwise.
- 2.2 If changes to the prices should occur up to the day of delivery, we reserve the right to amend our prices accordingly. However, this only applies to delivery periods longer than 4 months and price changes not exceeding 10%. If the price change is greater, a new price agreement must be concluded. If such an agreement should not be concluded, we have the right to withdraw from the contract in writing within 14 days.
- 2.3 Confirmed prices only apply when the quantities confirmed are accepted by the customer.
- 2.4 Packing, transport, freight and insurance costs are charged to the customer. A surcharge of € 20.00 net will be invoiced on orders with value under €250.00 net.

§ 3 Payment

- 3.1 The purchase price and/or agreed compensation for work including all costs are due for payment without reduction on receipt of invoice. Our invoices must be paid within 30 days without deductions. Payments are not deemed to have been received until the day on which we have access to the funds.

- 3.2 Payments must be made including VAT and without deduction of any prompt payment discounts or other deductions unless any other terms of payment are expressly agreed in writing.
- 3.3 Bills of payment are only accepted by express agreement and – also in the case of checks - only as an undertaking to pay and subject to our acceptance of them on a case by case basis. Discounting and other fees must be born by the customer and are due for payment immediately.
- 3.4 All payments are credited first to interest and costs and thereafter to our oldest receivables, irrespective of the customer's directions.
- 3.5 If payments are late, we will invoice interests on such payments at the level allowed by law. The assertion of additional claims for compensation is not allowed.
- 3.6 If payment should be late, checks and bills of exchange dishonored, payments suspended, the filing of proceedings for the arrangement of debt, failure to abide by the terms of payment or if circumstances arise likely to reduce the customer's creditworthiness, all our receivables – including in the event if a payment moratorium – are due for immediate payment. We are also entitled to perform services and make deliveries which are still outstanding only against the payment of cash or to withdraw from the contract after setting a reasonable grace period and to require compensation in lieu of performance.
- 3.7 Claims arising from the contractual arrangement may only be assigned by the customer with our express consent. Off-setting or retention are only permitted in respect of uncontested counterclaims which have been judged to be final and absolute. We are entitled to refuse the exercise of the right of retention in the form of a provision of a bond or a surety (Bürgschaft).

§ 4 Retention of title

- 4.1 All our deliveries are made with retention of title (goods subject to retention of title). Title does not pass to the customer until he has paid all his liabilities owed to us (including those arising from incidental claims) arising from our supplies and services. If we are trading with the customer on open account, the goods subject to retention of title are deemed to be collateral for our account balance including when payment is made against liabilities which have been specifically excluded.
- 4.2 If goods we have supplied should be mixed with or connected to other objects, the customer will assign to us (joint) title on the item arising therefrom in the ratio of the value of our goods subject to retention of title to the invoice value of the other goods used. If the customer should prejudice our rights set out above, he is obliged to pay us compensation. Dismantling and other costs are for the customer's account.
- 4.3 The customer may only sell the goods we delivered in the normal course of business and in such a case may only sell or use them (e.g. as part of a contract for work and services or a contract for work done and materials supplied) if his customer has not excluded the reassignment of the receivable arising from the resale or re-use of the goods. The customer is obliged to ensure that his customer delivers any retention of the right to consent to the assignment to us in the required form. The customer is not allowed to pledge by way of security or hypothecate the goods to which title is reserved.
- 4.4 The customer must inform us immediately of any attachment, even if such attachment is imminent or any other prejudice to the right of ownership in writing and to third parties and to us. In the case of attachments, a copy of the return of execution must be sent to us.
- 4.5 If a customer should default on payment, we are entitled to demand return of the goods subject to right of retention of title and to procure direct possession of such goods for us or via authorized persons, irrespective of where the goods are located. The customer is obliged to return to us the goods to

which title is reserved and is also obliged to provide us with the information necessary for us to assert our rights and to surrender documents for this purpose. The request for the goods is not deemed to be withdrawal from the contract. The same applies for the withdrawal of goods subject to retention.

- 4.6 In order to act as collateral for our claims (including future claims) arising from the business relationship, the customer hereby assigns to us all the receivables (including those on open account) with all ancillary rights which arise to him through the resale and other use of the goods subject to retention of title (e.g. combination, processing, installation in a building).
- 4.7 If the sale or other use of our goods subject to retention of title - in whatever state - should be made in conjunction with the sale or other use of objects to which third party rights are attached and/or in conjunction with the performance of services by third parties, the assignment of future claims is limited to the invoiced value of our invoices.
- 4.8 The customer is entitled to collect receivables which have been assigned to us. In the event of payment default, suspension of payments, the application for or opening of insolvency or out of court composition proceedings or other deterioration of the customer's assets, we may revoke this authorization to collect receivables. If so required, the customer must inform us of the receivables which have been assigned and of the parties owing such receivables, and provide us with all information necessary for the collection of these receivables, to surrender to us the associated documents and inform the debtor of the assignment. We are also entitled to inform the customer's debtors of the assignment and require the debtors to pay us.
- 4.9 If the realizable value of the collateral to which we have been entitled in accordance with the above provisions should exceed the value of our receivables by more than 10%, we are obliged to release the excess collateral at our option if so required by the customer.

§ 5 Supplies and service

- 5.1 Partial deliveries are only permitted to a reasonable extent. We may invoice partial payments to a reasonable degree. We reserve the right to correct orders so that they comply with packaging units. The order is deemed to be completed if plus or minus 10% of the quantity is delivered.
- 5.2 The delivery route, delivery method, packaging and other protection for deliveries are at our option. Transport risks are borne by the customer in all cases. We are entitled, but not obliged, to insure deliveries in the name and for the account of the customer.
- 5.3 The customer must arrange for any damage and/or loss to be recorded in writing by the carrier immediately on receipt of the goods and claims asserted.
- 5.4 Shipments that are returned to us will only be accepted insofar as the fact that they are being reported to us in advance, in which case the following conditions must be fulfilled:
- The identification that the customer receives when reporting a return shipment to us must be stated on the return documents and
 - All such shipments must be reported in our incoming goods department by means of the freight papers on which this identification number is noted.
- 5.5 The following rules apply to return shipments excepting those for return of defective delivered goods (Sect. 5.4):
- The goods were delivered at most 4 weeks before in case of deliveries within Germany, at most 6 weeks before in the case of deliveries to European customers and at most 8 weeks before in the case of deliveries to overseas customers.
 - The regulations of Section 5.4 apply to reporting, labeling and acceptance of return shipments.
 - Only return goods that are undamaged, unopened and have no additional writing or labels on them – so that these goods can be resold by us – will be accepted.

- d) The return delivery takes place at the expense and risk of the customer.
- e) In addition, a processing fee of 20% of the goods' value will be charged to the customer, whereby this charge shall be at least 30.00 Euros per return shipment. All delivery dates are ex works.

§ 6 Passage of risk and placement of performance

- 6.1 We bear the risk up until the time when the goods are handed over to the mail service or to the carrier or the company charged with organizing the transportation.
- 6.2 The customer also bears the risk before hand-over if he delays the hand-over.
- 6.3 The place of performance for delivery and payment is our company seat in Mörfelden.

§ 7 Time limits

- 7.1 If the customer should be in breach of his obligations of cooperation (e.g. by failure to call off the goods in time and refusal to accept them), we are entitled, at the end of a grace period which has elapsed without performance being made, to take the necessary steps ourselves and to deliver the goods or to withdraw from that part of the supply contract where performance has not been made. Our right to require compensation for breach of duty and compensation in lieu of performance is unaffected hereby. In the case of call-off orders, the customer must take the whole quantity within 12 months.
- 7.2 In the case of goods which we supply but do not manufacture ourselves, supply is subject to timely and correct deliveries to ourselves unless we are responsible for late, incorrect or short delivery.
- 7.3 Force majeure events extend the delivery time commensurably and entitle us to withdraw from the contract in whole or in part. Strikes, lockouts, disruptions of operations or other unanticipated circumstances for which we are not responsible and which materially impede delivery or render delivery impossible are of equal ranking with force majeure. This also applies if the above-mentioned circumstances occur during a delivery delay or at a supplier.
- 7.4 If the time period or an agreed date is exceeded, the customer has the right to require us to state within two weeks whether we are withdrawing from the contract or wish to deliver within a reasonable grace period. If we fail to provide a statement, the customer may withdraw from the contract in so far as performance is without interest to him.

§ 8 Liability for defects

- 8.1 The goods supplied are free from material defects if they comply with the product description or, in so far as no product description is available, comply with the relevant state of the art. We reserve the right to make changes in design and/or workmanship which do not prejudice the fitness for use or value of the goods which are to be supplied; such changes do not justify a complaint for defects. If defects do not prejudice the fitness for use or the value of the goods which are supplied or only prejudice such fitness and value to an immaterial extent, there are no grounds for claims due to defects.
- 8.2 Guarantees relating to the character and durability of the goods which are supplied are only deemed to have been accepted to the extent that we have expressly recognized the guarantee in writing as such. Guarantees which our suppliers have made in written guarantees, in relevant publicity or other product documentation, are not made by us. They obligate only the supplier who made this acceptance of guarantee.
- 8.3 Defects must be noted without delay and are excluded if they are not received by us within 2 weeks of the receipt of delivery. Defects which cannot be ascertained within this period even after the most careful examination must be reported to us without delay and not later than 2 weeks after discovery. We are not responsible for damage due to breakage of

glass during transportation caused after the transfer of risk. Breakages with a value of up to and including € 20.00 will not be replaced.

- 8.4 If the goods which were delivered should exhibit defects or if they fail to comply with a warranted property, we will, at our option, either rectify the defect free of charge or replace the goods by defect-free goods (subsequent performance). The customer must allow us, or a person authorized by us, the time and opportunity for such actions. If this does not occur or if modifications or repairs are undertaken to the object which is the subject of the complaint, we are released from liability for the defect.
- 8.5 If subsequent performance should fail or if subsequent performance is not made within a reasonable grace period imposed on us by the customer, the customer may require a reduction in price or withdraw from the contract. The purchaser cannot require reimbursement for his expenses incurred to no effect.
- 8.6 Claims by the customer for expenditure necessary for the purpose of subsequent performance (Clause 8.4) or reversal after withdrawal from the contract (Clause 8.5), especially transportation, shipping, labor and material costs are excluded in so far as the expenditure arose because the goods were installed in a location difficult to access. The same applies mutis mutandis if the goods which were delivered were installed in a location outside the Federal Republic of Germany.
- 8.7 Damage which occurs through incorrect or defective installation, commissioning, handling, operation or maintenance or through the use of unsuitable apparatus or apparatus other than the specified apparatus do not give rise to any grounds for claims for defects.
- 8.8 The time limits specified by law for the assertion of claims for defects applies. The time period commences on the day of our delivery. In the event of loss of life, bodily injury or impairment of health and in the event of gross or intentional neglect of duty on our part and in the event of fraudulent concealment of a defect or if properties have been warranted, the normal statutory prescription periods apply.
- 8.9 For the remainder, Clause 9 applies for claims for compensation. Additional claims by customers for defects are excluded.

§ 9 Compensation

- 9.1 We accept liability for compensation and reimbursement of expenditure incurred to no effect (§ 284 of the German Civil Code) for reason of breach of contract or non-contractual obligations (e.g. for reason of default or tortious acts) only in the case of intent or gross negligence; in the case of culpable loss of life, bodily injury, fraudulent concealment of a defect or acceptance of a warranty as to properties or under the German Product Liability Act (Produkthaftungsgesetz) we only accept liability for personal loss or for damage to property in the case of objects used for private purposes.
- 9.2 In addition we accept liability for breach of material contractual obligations also in the event of ordinary negligence. However, in this case our liability is limited to damage which could have been reasonably foreseen at the time of conclusion of the contract and which is typical under the contract.
- 9.3 In the case of loss caused by delay and in the event of ordinary negligence, we only accept liability amounting to 5% of the purchase price agreed with us.
- 9.4 The purchaser has to notify us immediately in writing about potential consequences of delay.
- 9.5 The provision above does not cause any change of the burden of proof in the detriment of the customer.

§ 10 Intellectual property rights, confidentiality

- 10.1 We retain ownership and all intellectual property rights of our designs, samples, drawings, technical documentation, cost estimates even if the customer has accepted the costs thereof. The customer may

only use the designs etc. in a manner agreed with us. He may not manufacture the goods without our written consent or cause the goods to be manufactured by a third party.

- 10.2 In so far as we supply goods in accordance with designs specified by the customer, the customer warrants to us that intellectual property rights and other third party rights are not breached by their manufacture and supply. He must compensate us for all losses resulting from such infringements.
- 10.3 The customer must retain confidentiality vis-à-vis third parties in respect of all information not in the public domain which was obtained as a result of this business relationship.
- 10.4 Drawings, pictures, sketches and weights are approximate/conditionally authoritative, save as confirmed expressly and bindingly. The customer guarantees that the documents do not infringe the third party rights of third persons. He has to indemnify us and hold us harmless for any loss damage or costs, including reasonable attorneys' fees, resulting from any third party claim, action or demand.

§ 11 Records

Documents, drawings and pictures supplied by us must not be made available to any third party or reproduced or used for any purpose outside this contract.

§ 12 Provision in respect of electronic business transactions

If we use a tele or media service within the meaning of § 312e of the German Civil Code for the purpose of the conclusion of a contract for the supply of goods or the performance of services, the customer waives

- provision and demonstration of a system which the customer can use to recognize and correct entry errors before the order is transmitted, and
- provision of information in respect to
 - the languages in which the contract can be concluded,
 - the steps to be carried out for the contract to be concluded and
 - storage of the contract text after conclusion of the contracts so that it is accessible by the customer.

§ 13 Final provisions

- 13.1 The place of jurisdiction and performance is Mörfelden in so far as the customer is a merchant. However, we are also at liberty to take legal action before the court competent for the customer's legal domicile.
- 13.2 If a provision of these General Terms and Conditions of Business or in other agreements between the customer and ourselves should become invalid, the validity of all other provisions or agreements is unaffected thereby. If a provision of these contractual terms and conditions is invalid, after taking into account the other provisions this provision is to be replaced by a valid provision which comes closest to the economic purpose of the invalid provision.
- 13.3 This contract is governed exclusively by the law of the Federal Republic of Germany. International law, including international conventions on the cross-border sale of goods, is excluded.

Safety instructions

Guarantee/safety of our products

A rigorous quality control ensures that you will receive high quality products without defects from us. If a product should nonetheless prove to be defective, as a matter of course you will receive a cost-free replacement. Because technically demanding components are dealt with, we can offer no guarantee for articles which are technically altered or damaged by the user.

Because it is the responsibility of the user to examine the technical suitability of the desired article, the same applies for specially manufactured articles which are produced according to customer specifications. We accept no liability for events or accidents emerging from improper handling or technical modification of our products by the user.

Safety and health

Pay particularly close attention to the hazard symbols (incl. hazard statements) and safety data sheets (SDS) in your operation and on the packaging of your chemicals. Whenever handling materials designated as hazardous, always use the prescribed personal protective equipment (PPE)!

Chemical compatibility

Due to the wide variety and the different compositions of solvents and substances available on the market, we can assume no guarantee for chemical compatibility. The materials with the best resistance according to the most up-to-date knowledge have been selected for S.C.A.T. products with particular consideration of the requirements for working with aggressive fluids. You may obtain information regarding compatibility with specific substances from the manufacturer of your chemicals or other expert sources.

A continuously updated table about: "Plastics - Chemical resistance to chemicals" is ready for you to download at www.scat-europe.com.

We would be pleased to offer you consultation during selection of suitable products for your application. The responsibility for the selection of the chemicals used lies with the end user. S.C.A.T. Europe offers no guarantee for the results and assumes no obligation or liability concerning the use of these products as regards their chemical compatibility, or abrasive effects.

Grounding and anti-static

Our products for safe grounding of containers and receptacles are specified for connection to installations with no current or voltage. These and the connection to electrically powered installations or electrically conductive components must only be carried out by qualified personnel! Please also observe the internal safety regulations of your company.

GHS 01
Explosives



GHS 02
Flammable Liquids



GHS 03
Oxidizing Liquids



GHS 04
Burst/
Cytrogenic burns



GHS 05
Corrosive



GHS 06
Acute Toxicity



GHS 07
• Irritant Effect
• Adverse health effects
• Damage of ozone layer



GHS 08
Serious and prolonged
health effects



GHS 09
Intoxications/
Long lasting effects
for environment





레보딕스(주) 홈페이지에 방문하시면 더욱 다양한 제품을 만나보실 수 있습니다
www.revodix.co.kr | sales@revodix.co.kr

본 사

(12930) 경기도 하남시 조정대로 150 (덕풍동)
하남지식산업센터 ITECO 334호
| TEL 031-790-1907 | FAX 031-790-1908 |

대전지사

(34016) 대전광역시 유성구 테크노3로 65 (관평동)
한신에스메카 415호
| TEL 042-824-5167/8 | FAX 042-824-5169 |

오송지사

(28576) 충청북도 청주시 흥덕구 공단로 134 (송정동)
세종테크노밸리 1012호
| TEL 070-7835-1344 | FAX 042-824-5169 |

