

MX Series II™ Modules



Automated Valve Solutions

Rheodyne MX Series II™ automated fluidic valves provide productivity enhancing solutions for today's demanding analytical methods. Combine MX Series II modular valves with your current instrument to support complex fluid switching and sample injection needs.



Flexible Automation

The MX Series II modular valves are flexible to meet changing needs. Several options are available for connecting the valves to your analytical instrument or PC, including contact closure, BCD, serial and USB. Commands can be sent to the MX Series II valves using your chromatography software or TitanMX™ software (included) for timed-events programmability. MX Series II valves can be controlled remotely or operated manually using the push-button front panel with LED position indicator.

Increase Laboratory Capability

The MX Series II modules are available in a variety of flow paths including options for Nano, Semi-prep, Low Pressure and Fast Chromatography applications up to 15,000 psi/1000 bar. These modules feature the reliable automation of Titan valves, saving valuable resource time and increasing overall productivity.

Reduce Downtime

The High Pressure and Fast Chromatography MX Series II modular valves feature the Rapid Replacement Pod™ design for easy maintenance. The Rapid Replacement Pod is a complete, factory assembled and tested liquid-end, providing virtually zero downtime maintenance. Traditional RheBuild® kits are also available.

The Low Pressure MX Series II modular valves make changing fluidic connections quick and easy with our patented TitanEX™ fitting-less tubing connection system. These long-life polymer valves meet the reliability needs of demanding applications.

MX Series II Modules

Dimensions given in inches and millimeters [in brackets].

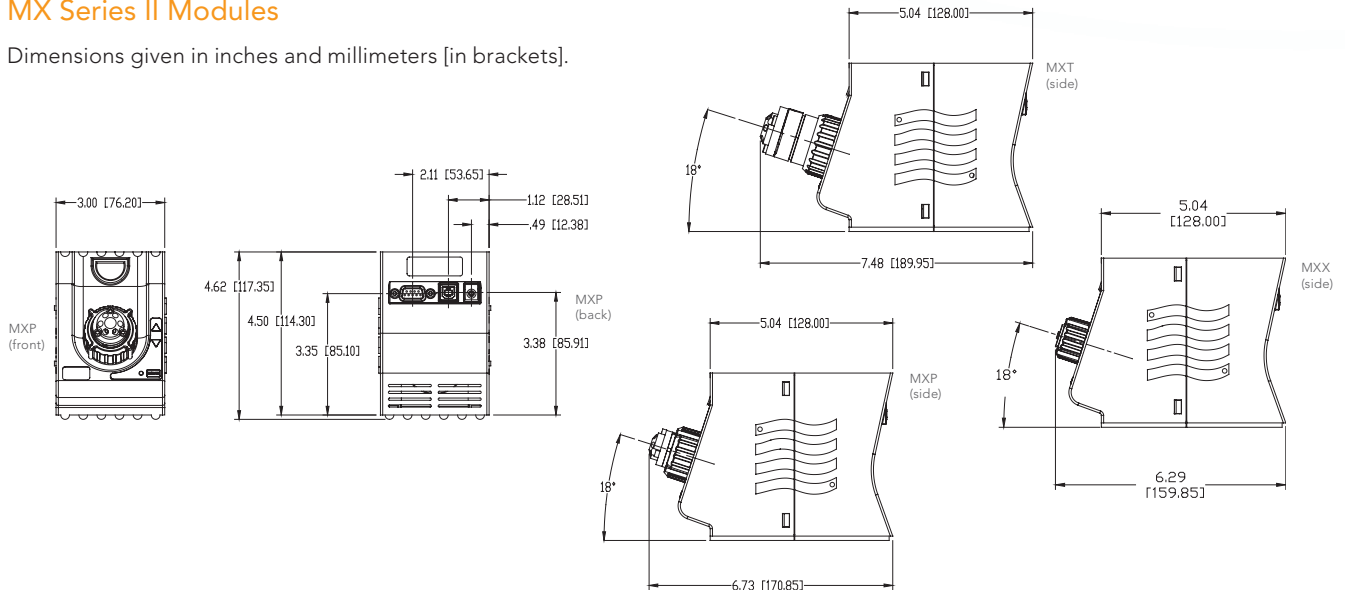

MX Series II Modules Available Include:

MXT for Fast Chromatography Applications, up to 15,000 psi (1000 bar)

Part Number	Description	Material	Stator Passages
MXT715-000	2-position 6-port Switching Valve	Stainless Steel UltraLife™*	0.011" (.28 mm)
MXT715-105	6-position 7-port Selector Valve	Stainless Steel UltraLife	0.011" (.28 mm)

MXP for High Pressure Applications, up to 6000 psi (400 bar)

Part Number	Description	Material	Stator Passages
MXP7900-000	2-position 6-port Switching Valve	Stainless Steel DuraLife™**	0.012" (.30 mm)
MXP7920-000	2-position 6-port Vertical Port Valve	Stainless Steel DuraLife	0.012" (.30 mm)
MXP9900-000	2-position 6-port Switching Valve	PEEK™	0.012" (.30 mm)
MXP7960-000	2-position 10-port Switching Valve	Stainless Steel DuraLife	0.010" (.25 mm)
MXP7970-000	6-position 7-port Selection Valve	Stainless Steel DuraLife	0.012" (.30 mm)
MXP9960-000	2-position 10-port Switching Valve	PEEK	0.010" (.25 mm)
MXP7980-000	2-position 6-port Nano Switching Valve	Titanium DuraLifell™**	0.004" (.10 mm)
MXP7986-000	2-position 10-port Nano Switching Valve	Titanium DuraLifell	0.004" (.10 mm)

MXX for Low Pressure Applications, up to 125 psi (9 bar)

Part Number	Description	Material	Stator Passages
MXX777-601	2-position 6-port Switching Valve	RPC-7**	0.016" (.41 mm)
MXX777-603	2-position Double Three-way Valve	RPC-7	0.016" (.41 mm)
MXX777-605	6-position 7-port Selection Valve	RPC-7	0.040" (1.0 mm)
MXX777-612	2-position 6-port Switching Valve	RPC-7	0.060" (1.5 mm)
MXX777-616	6-position 7-port Switching Valve	RPC-7	0.060" (1.5 mm)
MXX778-605	10-position 11-port Selection Valve	RPC-7	0.060" (1.5 mm)

* Proprietary Coating Materials

**RPC-7: Proprietary Polymer Combination

The company names and logos are trademarks or registered trademarks of the respective companies. DuraLife™, DuraLifell™, MX Series II™, Rapid Replacement Pod™, TitanEX™, TitanMX™, and UltraLife™ are trademarks and RheoBuild® is a registered trademark of Rheodyne LLC.

PEEK™ polymer is a trademark of Victrex plc. Precision Engineered Fluidics™ is a trademark of IDEX Health & Science. © 2007 IDEX Corporation.

Revised 10/1/07



Rheodyne LLC • IDEX Health & Science
 600 Park Court • Rohnert Park, CA 94928, USA
 Tel 707.588.2000 • Fax 707.588.2020
 info.rheodyne@idexcorp.com • www.rheodyne.com • www.idex-hs.com