

PCS Pump

SP-21 Series
SP-22 Series

OPERATION MANUAL

ATTENTION

Read this manual thoroughly in advance to use the instrument correctly.

After understanding the contents, keep it properly.

Warranty Certificate is attached at the end of the manual.

CONTENTS

• INTRODUCTION.....	p.1
1. SAFETY PRECAUTIONS.....	p.2
2. LIST OF ACCESSORY PARTS.....	p.3
3. NAMES AND FUNCTIONS.....	p.4
4. INSTALLATION.....	p.6
5. BASIC OPERATIONS.....	p.8
6. SPECIAL OPERATIONS.....	p.9
7. PRECAUTIONS IN HANDLING.....	p.12
8. MAINTENANCE.....	p.14
9. EXTERNAL CONTROL.....	p.20
10. TROUBLESHOOTING.....	p.23
11. SPECIFICATIONS.....	p.25
12. PRODUCT WARRANTY.....	p.26

INTRODUCTION

Thank you for purchasing PCS Pump (SP-22/SP-21 Series).

- ☆ This operations manual describes how to properly use PCS Pump (SP-22/SP-21 Series) and to prevent injuries and damages from occurring during operation and maintenance.
- ☆ In order to ensure safe operation of PCS Pump (SP-22/SP-21 Series), read this manual thoroughly to understand the contents before installation, tubing and operation.
- ☆ Each of the following cautions are important matters regarding safety, which must be observed fully
- ☆ Store this operation manual at a location that is readily accessible by operators for long period of use.

The following items describe the matters to be observed for safety.

- ① The safety precautions are ranked according to the classifications of DANGER, WARNING and CAUTION. The details are described in “Safety Precautions” in the following page, and the contents should be understood before using the pump.
- ② Note that the following items are excluded from the scope of our liability.
 - 1) Accidents caused by usage not described in this operation manual.
 - 2) Accidents caused by using replacement parts other than our genuine parts (See the list of attachments.) or those designated by us.
 - 3) Accidents caused by usage not specified in the contracted specifications.
- ③ Do not remodel before consulting with us.
- ④ Ensure to follow the descriptions in this manual when performing maintenance and periodical inspection.
- ⑤ Install your PCS Pump at a location other than those described in 7-2: Locations for Installation and Storage. Avoid installation to any other locations considered dangerous. Install the pump to a safe location to avoid possibilities of fire, injury and any unexpected disaster.
- ⑥ Warranty certificate is attached at the end of this operation manual. Handle it with care so as not to spoil or lose it. If this operation manual is lost, contact us indicating the model, production number and specifications (only for special specifications). A new operation manual will be issued, however, some of the warranty contents may not be available, so be sure to store this manual in a safe place.

1 SAFETY PRECAUTIONS

Prior to use (installation, operation, maintenance and inspection), read this operation manual carefully to understand proper use of the PCS Pump SP-22/SP-21 series.

Understand all the detail on the operation, safety and precautions concerning the pump before starting to operate.

Carefully store the operation manual at a location readily accessible by the operators.

< Definitions of the safety precaution marks >

Pay attention to the mark  that you will find throughout this operation manual.

 mark: This mark is shown when attention is needed before starting operation.

The word put beside this mark, DANGER, WARNING, or CAUTION, gives the reason why precaution is required. These are important safety matters that must be observed.

⇒The degree of hazard and damage that may be caused is explained by the classification as follows:

 **DANGER** : This mark indicates “an imminently hazardous situation which, if not avoided, is likely to result in death or serious personal injury.”

 **WARNING** : This mark indicates “a potentially hazardous situation which, if not avoided, could result in death or serious personal injury.”

 **CAUTION** : This mark indicates “a potentially hazardous situation which, if not avoided, could result in minor or moderate personal injury, or property damage only.”

2 LIST OF ACCESSORY PARTS

Check upon opening the package that the following parts are enclosed.

*NOTE : Contact your distributor if any of the attachment is missing or damaged.
 Troubles caused by connecting non-genuine parts are excluded from the scope of our warranty and liability.

Product Name	Standard	Qty.	Remarks
Power Cable		1 pc.	
3P Connector		1 pc.	
Fuse	1 A	2 pcs.	
Wrench	8 x 10	1 pc.	
2.5mm Hex. Wrench	2.5 mm	1 pc.	
PEEK Tube	1/16" x 0.25mm x 1m 1/16" x 0.5mm x 1m 1/16" x 0.75mm x 1m	1 pc.	SP-2x-02 SP-2x-12, 13, SP-2x-32, 33
EASY FITT ϕ 10	PEEK	1 pc.	Attached to Pump
STOP FITT	PEEK	1 pc.	Attached to Pump
Suction Needle		1 pc.	With Easy Fitt ϕ 10
Teflon Tube	1/16" x 1.0mm x 1m 3.0mm x 2.0mm x 1m	1 pc.	SP-2x-02 SP-2x-12, 13, 32, 33
Suction Filter	Stainless steel, 10um porous Polypropylene, 5um porous	1 pc. 1 pc.	SP-2x stainless steel SP-2x PEEK
Flat Seal Fitting	1/4-28UNF, PEEK	1 pc.	SP-2x PEEK
Flat Seal Ferrule	ETFE, 3.0mm	1 pc.	SP-2x PEEK
Double-lock Fitting	M8, stainless steel	1 pc.	SP-2x stainless steel
Double-lock Ferrule	ETFE, 3.0mm	1 pc.	SP-2x stainless steel
*Following attachments not attached to SP-21-02/SP-22-02 PEEK			
Suction Filter	Polypropylene, 5um porous	1 pc.	
Flat Seal Fitting	PEEK, 1/4-28UNF	1 pc.	
Flat Seal Ferrule	ETFE, 3.0mm	1 pc.	
*Following attachments not attached to SP-21-02/SP-22-02 Stainless steel			
Suction Filter	SS, 10um porous	1 pc.	
M8 Fitting	M8, stainless steel	1 pc.	
Double-lock Ferrule	ETFE, 3.0mm	1 pc.	

3 NAMES AND FUNCTIONS

3-1 < Name and Function of Front Panel Parts >

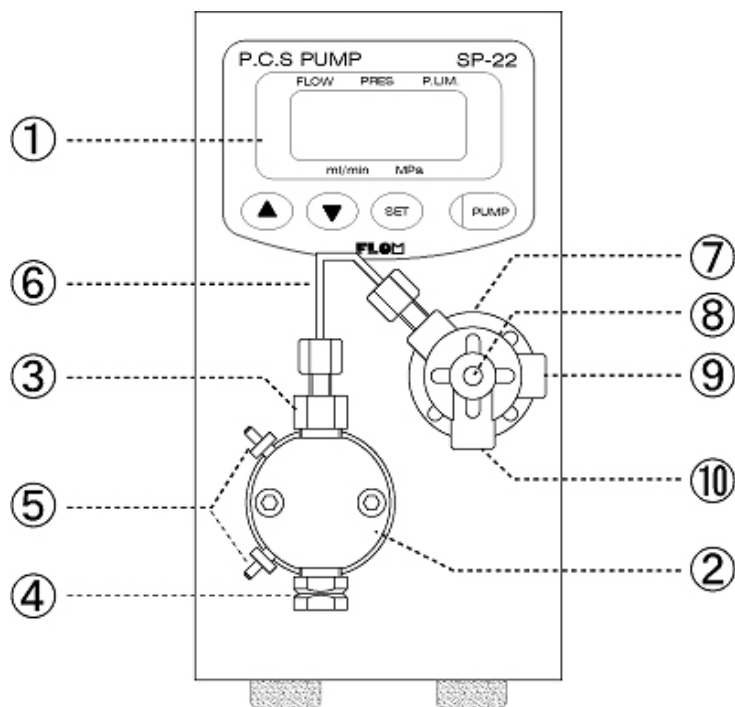

	Name	Function
Functions for SP-21 / SP-22 Series		
1	LCD Display Panel	Displays preset flow rate, current pressure, preset pressure limit, etc.
2	Pump Head	
3	Check Valve (Outlet)	
4	Check Valve (Inlet)	
5	Cleaning Port	To be connected to 2 x $\phi 3$ Teflon tube or silicon tube for cleaning of the pump-head's inner mechanism.
6	Connecting Tube	Check valve on discharge side and drain valve are connected with this PEEK tube.
7	Drain Valve (Pressure Sensor Holder)	Left connecting port is connected to liquid flow system, and right connecting port to draining system. Pressure sensor is mounted inside.
8	Drain Valve Opening/Closing Plug	Turning the plug clockwise will open the outlet port of Drain Valve and close the drain port. Turning counter-clockwise will open the drain port and close the outlet port.
9	Outlet Port	Connects to column.
10.	Drain Port	See "8 Drain Valve Opening/Closing Plug" above.

3-3 < Name and Function of LCD Display >

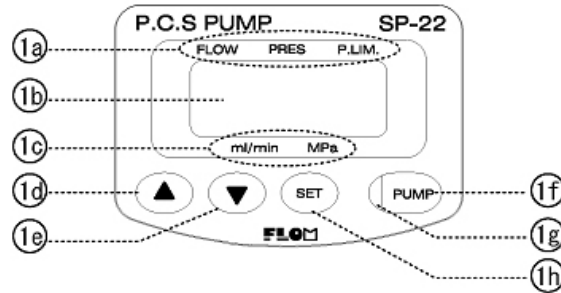

	Name	Function
1a	Display Indicator	A bar underlines either FLOW, PRES, or P.LIM. to indicate what is shown on display.
1b	LCD Display	Displays preset flow rate, current pressure, preset pressure upper limit.
1c	Units Indicator	A bar indicates the unit standard shown on display.
1d	UP Key	The number on display increases its value.
1e	DOWN Key	The number on display decreases its value.
1f	Ground Terminal	For connecting grounding wire.
1g	Pump LED	Blue LED is lit when pump is activated. Red LED is lit in case of error.
1h	SET Key	Changes LCD display items. (Preset Flow Rate→Pressure→Pressure Upper Limit Preset)

3-4 < Name and Function of Rear Panel Parts >

	Name	Function
11	Serial port RS232C	See “Communications Manual” for detail
12	Remote control port	See “Communications Manual” for detail.
13	Cooling fan	
14	Main Power Switch	
15	AC inlet	With fuse holder
16	Fuse Holder	Midget type 1A (2 pcs.)
17	Ground Terminal	For connecting grounding wire.

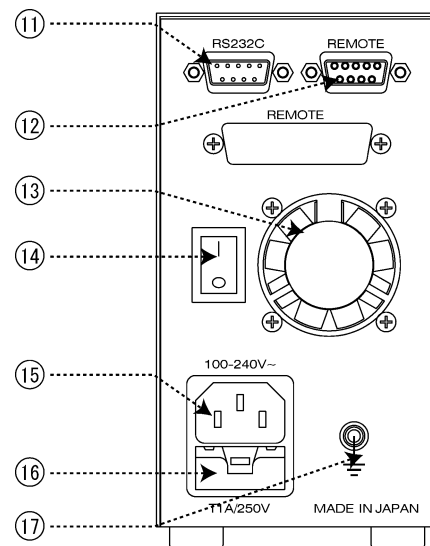

4 INSTALLATION

4-1 < Attachments >

Upon opening the package, check to see that all the attachments are enclosed. (See “2. List of Standard Attachments”)

*NOTE : Contact your distributor if you find a missing or damaged attachment.
Troubles caused by connecting a non-genuine part are excluded from the scope of our warranty and liability.

4-2 < WIRING >

⚠ WARNING

Hold the plug of the power cable and insert it to a receptacle.
Do not touch with wet hands. It may cause an electric shock.

⚠ CAUTION

If a large piece of equipment that may deliver a voltage shock to this equipment is installed in the same power supply system, secure a separate power source.

Connect the attached power cable to the AC inlet at the back of the pump and insert the cable to an indoor receptacle.

The power source rating is AC100V-240V and the power source frequencies of both 50/60Hz are acceptable.

The power cable enclosed as attachment to the product is of 3-lead grounding type.

For 2P type receptacles, use a conversion adaptor for 2P provided and ensure to ground as shown in the figure below.

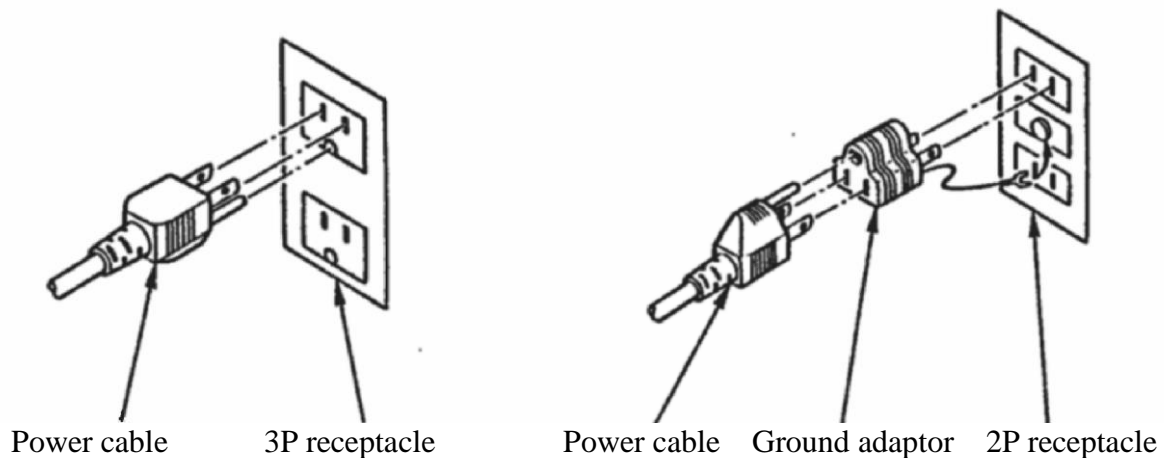

4-3 < Inlet Tubing >

Connect the attached Teflon tube to the inlet check valve.
Make sure to connect solvent filter at the other end of the tube.
Utilization of degasser is strongly recommended.

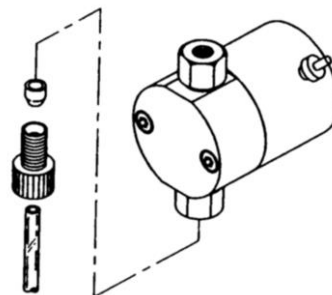

Fig.4-3: Suction Tube Tubing

4-4 < Removing Air >

■ SP-22 Series

Connect the attached suction needle to the drain port at the bottom of the drain valve.
Turn the plug counter-clockwise to open the drain valve.

Remove air in the pump head by drawing the solvent in with the syringe connected to the suction needle. Set the flow rate at approximately 1ml/min and activate the pump to adequately draw in the solvent.

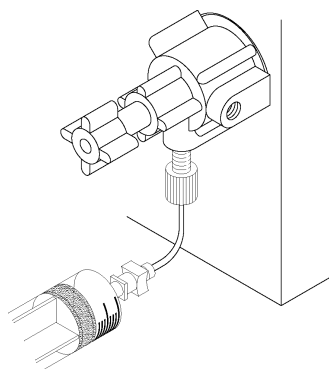

Fig. 4-4: Removing air

4-5 < Outlet Tubing >

With the pump OFF, connect the tube from Outlet Port to the next system component.

5 BASIC OPERATIONS

When you are not sure about the position of a key, refer to “3. Names and Functions” before proceeding. Numbers in the parenthesis in the following correspond to the number given to each part in “3. Names and Functions.”

5-1 < Changing the Display >

Pressing SET Key (1h) will change the panel display: Flow Rate Display → Pressure Display → Pressure Upper Limit Display along with underline in turn of the three values (1a) on the upper side of the panel.

In SP11 Series, however, the panel displays flow rate only.

5-2 <Flow Rate Setting>

Confirm that FLOW is underlined.

Set a flow rate with UP/DOWN Keys(1d)(1e).

Continuous key-pressing will allow the values on the display to change rapidly.

After setting flow rate, press PUMP Key (1f) to start pump operation.

Flow rate may be changed while the pump is on.

5-3 <Pressure Monitoring> * This function is for SP-22 Series only

Confirm that PRES(1a) is underlined.

LCD panel displays current pressure in Mega Pascal (MPa).

5-4 <Pressure Upper Limit Setting> * This function is for SP-22 Series only

Confirm that P. LIM LED (1a) is underlined.

Set a pressure upper limit with UP/DOWN Keys (1d)(1e).

Pressure upper limit value is changeable while the pump is in operation. When the pressure exceeds the preset value of pressure upper limit, pump operation will stop with a buzzer sound with error message “Er 1” indicated on the display panel. Then, press any key to restore operation, and set the pressure upper limit again.

5-5 <Dosing>

Outline: This is a mode in which the solvent volume is preset. The flow automatically stops when the preset volume is reached.

*** NOTE:** To operate in measured flow mode, change the flow mode in accordance with “6-2: Flow Mode Selection.”

Keep pressing the SET Key (1h) will add display parameter where both FLOW (1a) and PRES (1a) are underlined after display of pressure upper limit. (Display parameter of only A (3) will be underlined for SP-21 Series) Then, set the value of measured flow by means of UP/DOWN Keys (1d)(1e). Any value may be set for flow rate preset value.

Pressing the PUMP Key (1f) will commence the flow, and when the preset value is dispensed from outlet or draw in from inlet, the pump will automatically stop.

(*Note: The quick return mode does not function during this operation.)

6 SPECIAL OPERATIONS

Special operations provide various pump settings including the following:

- ① Flow mode selection
- ② Flow rate calibration
- ③ Pressure loss correction (*Function for SP-22 Series only)
- ④ Input mode selection

6-1 <User Parameters>

All the three functions above are to be set in user parameter mode. Turn power ON while pressing down SET Key (1h) to switch to user parameter input mode.

In the user parameter input mode, PUMP LED will be lit and display 1: 1 in blinking. The figure at the left represents the function item, while the right figure shows preset value. Press SET Key (1h) to change the function and press UP/DOWN Keys (1d)(1e) to change the value. Enter any value to the function desired, and press PUMP Key (1f) to fix the value. You can end the user parameter mode by pressing SET Key repeatedly until End appears on display and then press PUMP Key (1f).

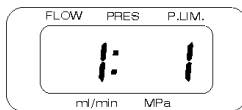
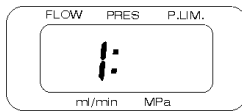

Fig. 6-1 User Parameter

6-2 <Flow Mode Selection>

Enter user parameter input mode to make the selection. (See “6-1 User Parameters”)



The function item “1” in the left is the parameter to set flow mode.

At this time, enter any value using UP/DOWN Keys (1d)(1e) on the right side referring to the following. Press PUMP Key (1f) to confirm the value, and turn ON the power again.

List of Flow Modes

- ① Normal flow mode
- ② Quick return flow mode

6-3 <Flow Rate Calibration Input>

Enter user parameter input mode to set the parameter. (See 6-1: User Parameters)



The item value “2” in the left is the parameter to set flow rate calibration.

At this time, input correction value in increments of 0.1% on the right side using UP/DOWN Keys (1d)(1e). Press PUMP Key (1f) to fix the preset value.

(Example) To input a correction value of +1.2%



As shown on the left, input 12 and fix the value.

(Example) To input a correction value of -0.5%



Input the value in the same manner as the above. You will not see a display of “-”(negative sign) at this time, but can confirm it by pressing either of the UP/DOWN Keys (1d)(1e) continuously. Make sure to check it before final setting.

6-4 <Pressure Loss Correction Value Input> * Function for SP-22 Series only

Enter user parameter input mode to set a parameter. (See “6-1: User Parameters”)



The function item “3” in the left is the parameter to set pressure loss correction value.

Input a correction value in increments of 0.1%/1MPa using UP/DOWN Keys (1d)(1e). Press PUMP Key (1f) to fix the value.

(Example) Correction input in the case of 12.5% loss caused at 10MPa



As the loss rate per 1MPa is 1.25%, the correction value is made to 1.3% by rounding the second decimal place. Input the figure without decimal point, “13.”

6-5 <User Parameter Mode Selection>

Enter user parameter input mode to make the selection. (See “6-1 User Parameters”)

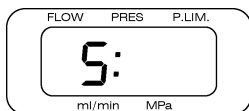

The function item “5” in the left is the parameter to set flow input mode.

At this time, enter any value using UP/DOWN Keys (1d)(1e) on the right side referring to the following. Press PUMP Key (1f) to confirm the value.

<u>List of Flow Input Modes</u>	
①	Standard flow mode
②	Dispensing mode (inlet)
③	Dispensing mode (outlet)

6-5 <Automatics Pressure Zero Mode> * Function for SP-22 Series only

Enter user parameter input mode to make the selection. (See “6-1 User Parameters”)

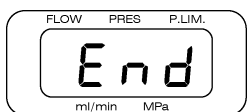

Press “PUMP” (1f) when the function item “End” in the display.

Before pressing PUMP (1f), turn the plug counter-clockwise on Drain Valve to release flow pressure. User Parameter Mode ends after zeroing pressure value automatically.

6-6 <Other Modes>

Item	Mode	Value	Description
7	Motor activation speed	-10 ~ +10	
8	Lower pressure limiter sensitivity	1 ~ 999 (sec)	Time to stop pump below set value (SP-22 series only)
9	Stop bit (RS232C)	1 = 1 bit 2 = 2 bit	Default setting = 2 bit
11	Lower pressure limiter set value	0 ~ 349 (×0.1MPa)	(SP-22 series only)
12	Error signal output (RS232C)	0 = No error output 1 = Error output	Default setting = 1

7 PRECAUTIONS IN HANDLING

7-1 <Precautions for Use>

⚠WARNING : The following items are WARNINGS that must be adhered to.

- ☆ Do not apply organic solvents or aqueous solutions to the panel cover. If applied by mistake, cut off the power, pull out the plug from the receptacle, and quickly wipe the liquid off the cover. Avoid starting up the equipment until it is completely dried up. Fire, electric leakage, electric shock or equipment failure may be caused. Consult your distributor when it is likely that a substantial amount of solvent got in the equipment.
- ☆ Do not insert foreign objects such as stainless steel tubes or metal pieces through ventilation port of the cover into the equipment body. Electric leakage, electric shock, equipment failure or physical injury may be caused.
- ☆ Even when the pump is suspected to be out of order, avoid repairing or dismantling it by yourself. Fire, electric shock or physical injury may be caused.
- ★ To replace seals in the pump head or the head guide, turn OFF power at the rear panel and pull out the power cable from the AC inlet. Avoid pulling and inserting the plug with wet hands. Do not dismantle the equipment for a purpose other than seal replacement. Electric shock or physical injury may be caused. Seal replacement should be performed following “8: Maintenance.”

⚠CAUTION : The following items are CAUTIONS that must be adhered to.

- ☆ This equipment cannot be used with power supply other than AC100V-240V(50Hz/60Hz). Any other power supply may cause fire, electric shock or equipment failure.
- ☆ When an anomaly occurs, immediately stop the operation, and contact us with description of the anomaly details. Continuous use the equipment may result in fire, electric shock or physical injury.
- ☆ Avoid improper handling of power cable such as forced flexing, processing, pinching, knotting, binding, or laying under heavy object. Fire, heating or electric shock may be caused.
- ☆ Avoid covering ventilating port on the side and exhausting port on the rear panel with paper and/or tape. Fire, heating and equipment failure may be caused.
- ☆ It is not necessary to firmly tighten PEEK hex. setscrews connected to the discharge side of the pump head and to the drain valve. The right position of the setscrews is at 60° or so from the position that the setscrews stop by hand tightening. Be careful to avoid excessive tightening of the setscrews. Equipment failure may be caused.
- ☆ To supply buffer solution, seal in distilled water from the cleaning port and replace the solvent about once a week. This work will contribute to improved durability by preventing liquid leakage caused by wearing of plunger seal and plunger. See “8: Maintenance” for details. (An optional cleaning kit is available.)

7-2 <Locations for Installation and Storage>

⚠DANGER

: The following contents are DANGER that must definitely be adhered to.

- ☆ This equipment is not made to explosion-proof specifications. Do not use the equipment in an explosive atmosphere. Death, physical injury or fire may be caused.
- ★ Despite the light weight and the compact design of the equipment, it must not be carelessly placed above operator's head where it may fall off. Death or physical injury and equipment failure may be caused.

⚠CAUTION

: The following describes places that are not suitable for installing the pump. Avoid the following to prevent electric leakage and equipment failure from happening.

- ☆ Outdoor use and storage
- ☆ Use and storage in the vicinity of corrosive gas
- ☆ Use in the vicinity of high-frequency generators. Strong electromagnetic wave may affect CPU and cause its erroneous actuation.
- ☆ Use at a location with excessive vibration or at an instable location
- ☆ Installation at a location under direct sunlight or in the vicinity of a heater
- ☆ Use or storage at a location with high humidity
- ☆ Use or storage at an extreme temperature. Use and storage at room temperature is a precondition - ambient temperature at 4-45°C. No dew condensation is allowed.
- ★ If the pump is not likely to be used for a long period of time, displace substance in the interior space of the head and the cleaning port with distilled water or alcohol. Especially after use of a buffer solution, remember to displace with distilled water.

*NOTE: Place solvent bottles at the same level as the pump head or higher.

8 MAINTENANCE

8-1 <Cleaning of Plunger>

CAUTION

: Make sure to strictly observe the following to prevent failure of the driving unit.

Use of a buffer solution for elusion may generate crystallized salt that may spoil plunger and/or significantly wear off the seal. Inject distilled water with a syringe after connecting silicon tube to the upper portion of the cleaning port on the head (See “3. Names and Functions”) and clean the plunger to prevent salt precipitation.

The cleaning mechanism is not automatic. Replace with new distilled water from once three days to once a week.

An optional silicon tube kit for cleaning is available. But any tube you may have can also be used for connection.

“CLEANING PUMP WP-11” for automatic cleaning is also available in our product line.

Please feel free to contact us for detail.

The illustration below shows the method of tubing on the cleaning side. Distilled water injecting port is connected to the top. Set the opposite side to a beaker etc. for waste water.

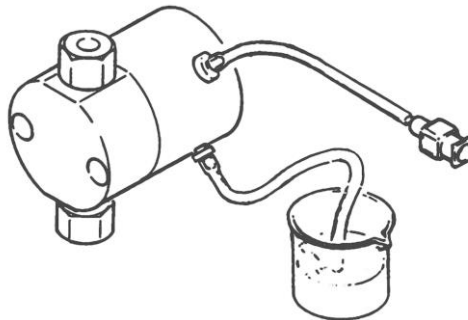

Fig. 8-1 Plunger Cleaning

8-2 <Replacement of Plunger Seal>

Plunger seals are expendable parts. Replace them periodically.

Normally, only the plunger seal inserted inside the pump head is to be replaced.

When the cleaning port is used, replace the plunger seal of the pump head guide as well.

Follow the procedure below.

- ① Remove the tubing of the check valves for suction and discharge.
- ② Remove the pump head fixing screw using the attached hex. L wrench.
- ③ Pull out pump head from the body.
- ④ Take out the worn-out seal from the head.

After applying a stopper to the discharge-side check valve of the head, attach a suction needle to the suction-side check valve, and fill water in with a syringe until it overflows the head. Take an optional seal-insertion tool and fully insert its round rod end that is longer than the other end (i.e. end that is not tiered) . The seal will come up due to inner pressure. Repeat insertion with additional water and the seal stuck to the tool may be removed. If the O-ring remains inside, make sure to remove it. See the illustration below (Method of Seal Removal).

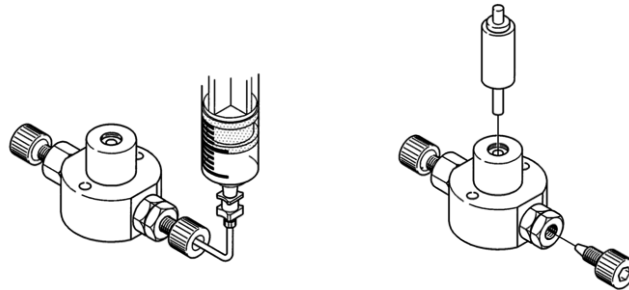

Fig. 8-2a Method of Seal Removal

⑤ Insert a seal into the head.

Take the optional seal-insertion tool and set a new seal to its tiered end seeing to it that an O-ring is placed on the outer side.

Make sure that the seal is attached to the O-ring, since it will be damaged if inserted separately. Insert the tool together with the O-ring and seal into the head slowly in a circular motion. Note that hasty insertion will damage the O-ring and cause liquid leakage.

Press the seal-insertion tool until it is leveled with the pump head, then pull out the tool and set the pump head to the body to complete seal insertion. See the illustration below (Method of Seal Insertion).

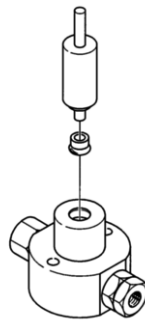

Fig. 8-2b Method of Seal Insertion

⑥ Attach the head to the body and tighten the fixing screw to set the tubing, which completes seal replacement. The following illustration shows the parts composing the driving unit.

■ SP-22/SP-21-12,13,32,33 Driving Unit

1	Pump Head
2	Plunger Seal
3	Back-up Ring
4	O-ring
5	Head Guide
6	Cleaning Seal
7	Plunger Guide
8	Spring
9	Plunger Adaptor
10	Plunger
11	Stainless Steel Ball
12	Spacer

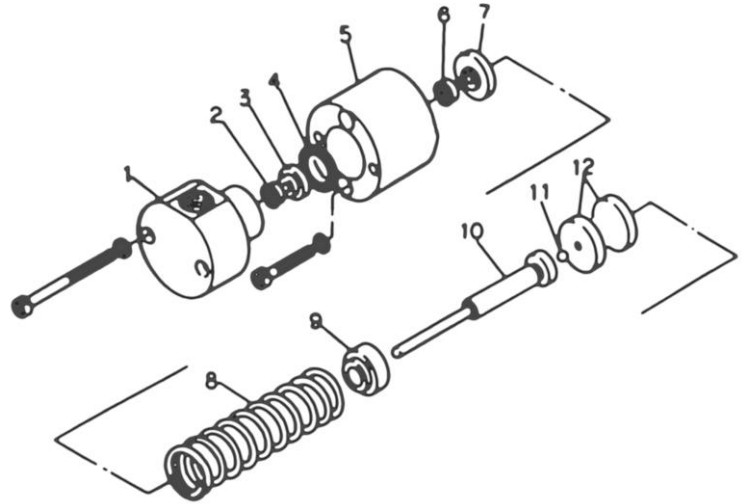

Fig. 8-2c SP-22/SP-21-12,13,32,33 Driving Unit

■ SP-22/SP-21-02 Driving Unit

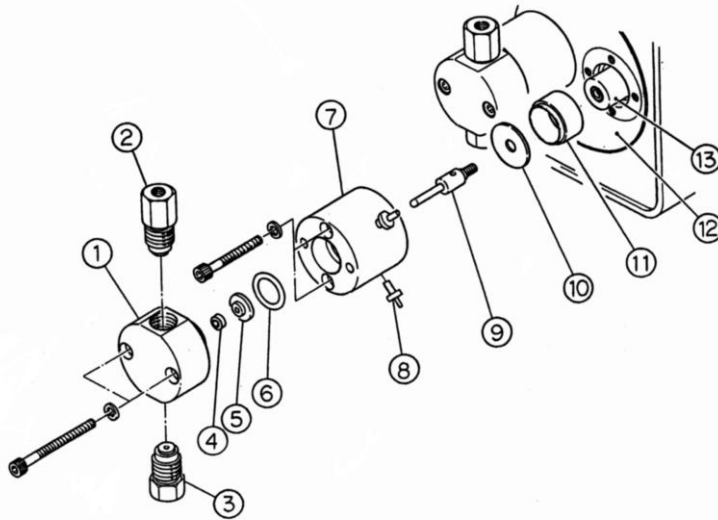

Fig. 8-2d SP-22/SP-21-02 Driving Unit

1	Pump Head	2	Discharge-Side Check Valve	3	Suction-Side Check Valve
4	Plunger Seal	5	Back-up Ring	6	O-ring
7	Head Guide	8	Cleaning Port	9	Plunger
10	Cleaning Seal Packing	11	Stainless Steel Ball	12	Pump Base
13	Rod				

8-3 <Method to Clean Check Valve>

Most of flow troubles are caused by poor operation of a check valve, typically caused by gas bubbles, foreign matters accumulated between the ball and the valve seat, or when the ball dries up and sticks to the valve seat.

See “4-4: Procedure to Remove Air” when poor operation is caused by gas bubbles.

If the flow is not restored after removing bubbles, filth or foreign matter is suspected between the ball and the valve seat. Clean them following the procedure below.

- ① Remove the tubing of the check valves for suction and discharge. Use the attached spanner (8mm) for removing the tubing on the discharge side.
- ② Remove the check valves for suction and discharge from the pump head using the attached spanner (10mm).
- ③ Place the check valves in a beaker. Fill the beaker with alcohol or distilled water (Use distilled water when buffer solution served as mobile phase), to clean the check valves by supersonic cleaning for approx. 10 to 20 minutes.
- ④ After cleaning, attach the check valves to the pump head. Be careful not to mix up the suction check valve and the discharge check valve, and attach each of them on the right side.
Finally, finger-tighten the check valves firmly to the pump head before tighten another 90° or so using a spanner.
* NOTE: Excessive tightening with spanner may cause damage. Be careful not to overdo.
- ⑤ Install the tubing for the suction and the discharge check valves.
Finger-tighten the tubing on the discharge side firmly as you did with the check valves and tighten another 60° or so using a spanner.
* NOTE: Excessive tightening with spanner may cause damage. Be careful not to overdo.
- ⑥ After completion of tubing installation, remove air by drawing solvent in. See “4-4 Procedures to Remove Air.”

In most cases the above should resolve problems causing filth and dirt adhesion or a stuck ball to achieve normal operation. If the poor functioning still would not improve, disassemble the equipment for thorough cleaning.

To disassemble a check valve, first take out the check valve in question and insert the attached STOP FITT into the joint turning it with your fingers. This will gradually move the interior out from the valve cartridge. (See the next page for check valve interior.)

<Check Points for Assembling>

- ① The mirror side of the valve seat is to face the ball. (Light reflection will make identification easy.)
- ② Use forceps for setting the ball and the valve seat in the valve seat housing.
- ③ Make sure to place seal A that is thinner than seal B to the center of the valve cartridge.
- ④ Insert the valve housing that was set in ② into the cartridge as shown in the illustration.
Note that the orientation of the valve seats on the suction side and the discharge side are different from each other.
- ⑤ Press seal B evenly. (Seal B is an expendable item. Use of a new seal is recommended.)

■ Parts List of Check Valve for SP-22/SP-21-12,13,32,33

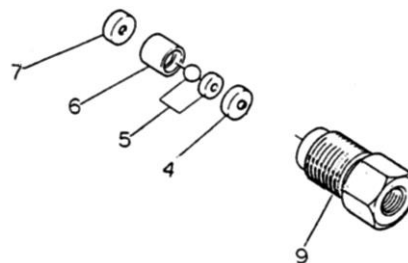
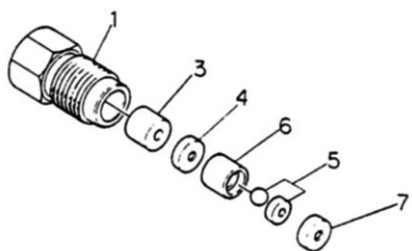

Fig. 8-3a Check valve on Discharge Side

Fig. 8-3b Check valve on Suction Side

INDEX No	Product No.	Product Name	Standard
1	#2115	1/16" Valve Cartridge	No.10-32 UNF PEEK
9	#2114	1/4-28 Valve Cartridge	1/4-28 UNF PEEK
3	#2005	Tapered Spacer	PEEK
4	#2006	Seal A	1.5mm PCTFE
5	#2008	Ball & Valve Seat	Ruby & Sapphire
6	#2009	Valve Seat Housing	PEEK
7	#2007	Seal B	2.0mm PCTFE

■ Parts List of Check Valve for SP-22/SP-21-02

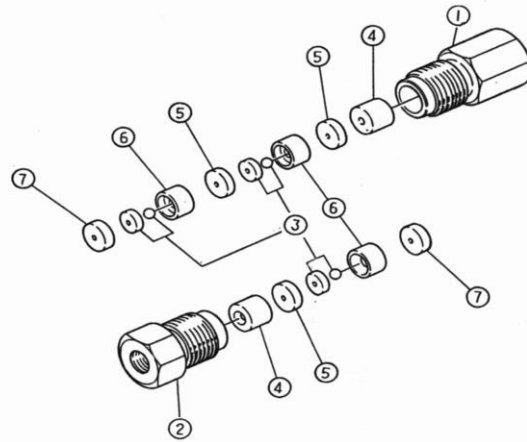

Fig. 8-3c Check Valve for SP-22/SP-21-02

INDEX No	Product No.	Product Name	Standard
1	#2515	Valve Cartridge (Discharge)	No.10-32 UNF PEEK
2	#2510	Valve Cartridge (Suction)	No.10-32 UNF PEEK
3	#2514	Ball & Valve Seat (Micro Type)	Ruby & Sapphire
4	#2005	Tapered Spacer	PEEK
5	#2511	Seal A (Micro Type)	1.5mm PCTFE
6	#2512	Valve Seat Housing	PEEK
7	#2513	Seal B (Micro Type)	2.0mm PCTFE

9 EXTERNAL CONTROL

For external control functions, this equipment supports a digital flow rate input function and analog flow rate input function, which is optional. For use of the analog flow rate input function, contact us.

9-1 <External Control with DSW (Digital Switch)>

The power to the on-board photocoupler can be supplied from this equipment (internal power use) or a unit you use (external power use). If noise to devices such as a detector is to be a special concern, it is recommended to take external control with external power use.

[Connections]

A Connection for the internal power use (the numbers are those of the 25-pin D-sub connector.)

- Connect pin 1 (+5V output for pull-up) with pin 4 (pull-up COM).

	Signal	Description	
1	START/STOP input	Start/Stop pump.	
		Photocoupler OFF→ON	Pump start
		Photocoupler ON→OFF	Pump stop
2	CPU RESET input	Reset CPU inside. Reset pump to default setting.	
		Photocoupler ON	Reset CPU (Pump stop)
		Photocoupler ON→OFF	Reset pump to default setting.
3	Error signal	Signal ⇒ Below DC30V 10mA	
		Error	Photocoupler ON
		Normal	Photocoupler OFF

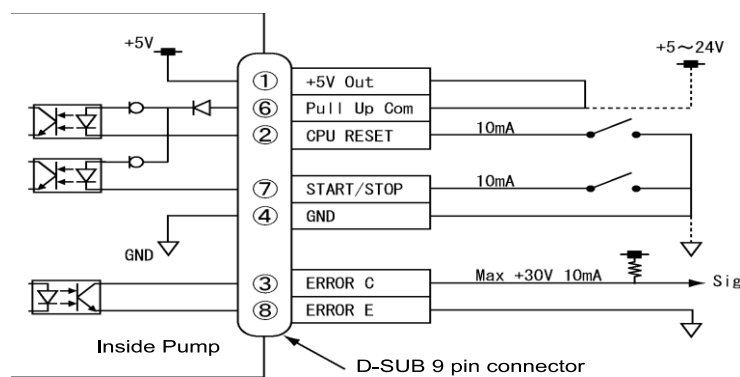

Fig. 10-1a Internal power use connection diagram

*NOTE: When internal power use is applied for control, noise may cause a malfunction. If a cable of 1 m or longer is used, apply the external power use according to the descriptions of the next section.

9-2 <Serial Port Communication>

This communication system allows you to connect this pump and the host computer through an RS-232C cable to monitor various data and activities. Use cross cable for connection of pump and computer. The serial port on pump is a male type connector.

<Data Format>

Baud rate	9600 bps
Data	8 bit
Parity bit	None
Stop bit	2 bit (or 1 bit)
Flow	None

<List of Commands>

Every command shares the same command structure of the first letter “P” and the pump number that follows the “P.” The next comma-separated bit is the beginning of the data, ending with “CRLF.” Note that ASCII codes must be used for all the commands.

■ PC→Pump

Command	Description	Note
P1, G1, 1	Pump start	
P1, G1, 0	Pump stop	
P1, S2, n	Quick return setting	“n” indicates the mode setting: n : 1 = No quick return : 2 = Quick return activated
P1, S3, nnnnn	Flow rate	“nnnnn” indicates flow rate. The flow rate value is in <u>ul/min</u>
P1, SE, n	Error signal	“n” indicates the error signal emission. n : 0 = No error signal : 1 = Error signal emitted
P1, S6, nnn, mmm	Pressure limiter setting	“nnn” sets the upper pressure limit value, “mmm” the lower pressure limit. The values are in 0.1MPa.
P1, Q2	Pump status	Respond with pump status indicated as: <u>P1, Q2, n, 00, mmmmm, yyy</u> n : 0 = Pump stop 1 = Pumping 9 = Error D = Pump stopping mmmmm : The flow rate value is in ul/min. yyy : The flow pressure value is in 0.1MPa.
P1, Q3	User set value	Respond with user set value as: <u>P1, Q3, n, mmmmm, 00000, 00000, yyy, zzz</u>

		n : Pulse reduction mode status mmmm : Flow rate value in ul/min. yyy : Upper pressure limiter value in 0.1MPa. zzz : Lower pressure limiter value in 0.1MPa.
P1, Q5	Cylinder cycle count	Respond with total cycle count of pump cylinder as: <u>P1, Q5, nnnnnnnn</u> nnnnnnnn : Total cycles
P1, R, n	Error reset	Reset error with “n” as: n : 2 = Rest error. : 4 = Reset cylinder cycle count.

■ Pump→PC

Command	Description	Note
P1, OK	Command acknowledgement	Pump responds to acknowledge the reception of command.
P1, E, nn	Error signal	Pump responds when there is an error in operation or error in command. nn : 10 = Command unknown. 20 = Wrong values in command. 21 = Value in command exceeding max value. 22 = Value in command exceeding minimum value. 33 = Command cannot be received temporarily. 35 = Command prohibited. 61 = Upper pressure limiter error. 62 = Lower pressure limiter error. 66 = Overheat error. 67 = Motor rotation error.

10 TROUBLESHOOTING

10-1 <Error Displays and Countermeasures>

Er 1	Pressure Upper Limit Error (SP-22 Series only)
Pressure load is higher than the preset upper limit value.	
☆ Check tubing and column.	
☆ Start checking the tubing from a joint that is farthest from the pump.	
Er 2	Pressure Lower Limit Error (SP-22 Series only)
Pressure load is lower than the preset upper limit value.	
☆ Check tubing and column.	
☆ Start checking the tubing from a joint that is farthest from the pump.	
Er 6	Overheat
Equipment interior has heat more than the standard level.	
☆ Check if sufficient space is secured at the side ventilation port and the rear exhaustion port.	
Er 7	Motor Rotation Error
Motor torque is not sufficient. Abnormal load is caused.	
☆ Do not start pump without solving problem of irregular flow (poor operation of check valve).	
☆ Abrupt pressure load caused during flow will disable the flow.	
☆ Malfunction of interior sensor caused by dust will disable the flow.	
On these occasions, please ask for a service visit.	

10-2 <Other Troubles and Countermeasures>

<p>● Power supply does not turn on.</p>
<p>☆ Check main power supply (breakers), and receptacles/socket.</p> <p>☆ Check fuses.</p> <p>☆ Check AC voltage. (Acceptable range for use AC100-240V)</p> <p>☆ Supplying voltage over AC 250V will damage power supply switching, requiring a service visit.</p>
<p>● Abnormal noise is heard.</p>
<p>☆ Check if the pump head is in contact with the front panel. Allow sufficient length of tubing from the liquid flow system port to the column.</p> <p>☆ Check if the pump is in contact with other equipment. Air inlet port is located on the side. Allow a space of more than 2cm on the side.</p> <p>☆ Check if tubing is in contact with the blower fan at the rear panel.</p>
<p>● Abnormal odor is smelled.</p>
<p>☆ Ask for a service visit immediately after turning the power OFF. Advise service personnel the detail of the problem.</p>
<p>● Flow rate is not stabilized.</p>
<p>☆ Check the AC voltage. (Acceptable range for use: AC 100-240V) Voltage lower than AC 90V will result in insufficient motor torque inhibiting proper functions.</p> <p>☆ Check if air remains in the pump head. See (“Procedure to Remove Air”) and remove air from inside the pump head.</p> <p>☆ If plunger seal is worn out, see (“8-2 Replacement of Plunger Seal”) to replace it.</p> <p>☆ Poor operation of check valve causes irregular flow. If this is the case, see “8-3 Method to Clean Check Valve” to perform supersonic cleaning and cleaning after disassembly.</p> <p>☆ Pressure during flow may cause pressure loss. (Example) Loss of approx. -14.2% at a flow rate of 2ml/min., and 10Mpa pressure for 021-01.</p>

11 SPECIFICATIONS

Model	SP-22-02 SP-21-02	SP-22-12 SP-21-12	SP-22-13 SP-21-13	SP-22-32 SP-21-32	SP-22-33 SP-21-33
Flow Method	Single plunger reciprocal movement method				
Flow Rates (ml/min.)	0.01~1.00	0.01~2.00	0.1~5.00	0.1~10.0	0.1~20.0
Maximum Pressure (MPa)	20.0	20.0	10.0	5.0	2.0
Flow Rate Setting	UP/DOWN Key Input BCD contact point input (External digital input of flow rate) Analog signal input (External analog input of flow rate *Optional)				
Pressure Sensor	“Equipped” for SP-22 Series/“Not equipped” for SP-21 Series				
Plunger Diameter	φ 2	φ 3.2	φ 3.2	φ 7	φ 7
Plunger Stroke	2mm	2mm	4mm	2mm	4mm
1-Head Discharge Volume	6 μ l	16 μ l	32 μ l	77 μ l	154 μ l
Flow Rate Stability	±0.5%				
Wetted materials	PEEK, ruby, sapphire, Dyflon (Inert standard specification)				
External Control	PUMP ON/OFF input CPU RESET input Error output Flow rate setting by BCD contact point input Flow rate setting by analog signal, 0-1V, compatible with 4-20mA(*Optional)				
Functions	Pulsating flow control mode (Quick return mode) Measured flow mode (0.01 or 0.1 – 1000ml) Pressure loss correction, Pressure limit (SP-22 Series only)				
Power Source	AC 100V – 240V (Compatible with 50/60Hz)				
Dimensions	80(W) x 285(D) x 145(H) excepting projecting portions				
Weight	Approx. 3.0 kg				

*Maximum pressure (MPa) is a maximum instantaneous pressure and does not mean a constant maximum pressure at the setting of maximum flow rate.

* The appearance and specifications of the product may be altered without prior notice.

*The photos and illustrations etc. in the operation manual may be slightly different from the actual product due to product improvement.

12 PRODUCT WARRANTY

WARRANTY CERTIFICATE

Thank you for purchasing PCS Pump (SP-22/SP-21 Series).
FLOM Corporation provides this equipment with one-year product warranty.
Should a failure occur to the product within the warranty period and is covered by the warranty, we will repair or replace parts free of charge, provided, however, that the failures due to the following causes and the like will not be covered by our warranty.

- 1) Failure caused by not adhering to the instructions given In “7: Precautions in Handling” of this operation manual.
- 2) Failure caused by improper use.
- 3) Failure caused by repair or remodeling not performed by us.
- 4) Failure caused by earthquake, disaster, or natural calamity.
- 5) Failure caused by a cause attributable to an equipment other than this equipment.
- 6) Failure caused by using the equipment in a severe environment involving high temperature, high humidity, extremely low temperature, or corrosive gas, or at a regularly vibrating location.
- 7) Replacement of expendable parts, or parts corresponding to this classification.

- Ensure to fill out the following items. Failure to provide the information will result in exclusion of your equipment from our warranty.

Product Model

Product Number

Date Delivered

Distributor



FLOM Corporation.
5-32-10 Shinmachi
Ome City, Tokyo 198-0024
TEL 0428-30-7454
FAX 0428-30-7452